

Kompakter Antrieb zum Steuern und Regeln von Armaturen. Ausgestattet mit extra Endschaltern (ELS), Handrad. Aufbau nach ISO 5211/DIN 3337, DIN Stecker, Heizung, elektronischer Begrenzer.

**Technische Daten**

<b>Spannungsbereich</b>	24 - 240 V AC/DC (50/60 Hz)
<b>Stromaufnahme</b>	0,1 A - 1,2 A
<b>Laufzeit s/90°</b>	10 s ± 10%
<b>Heizung</b>	3,5 W
<b>Losbrechdrehmoment</b>	25 Nm
<b>Arbeitsdrehmoment</b>	20 Nm
<b>Einschaltdauer [ED]</b>	75%
<b>Schutzart</b>	IP65
<b>Temperaturbereich</b>	-20 °C bis 70 °C
<b>Flansch</b>	F03/F04/F05 - F07 via Kit
<b>Aufnahme</b>	9 mm, 11 mm, 14 mm Achtkant
<b>Anschluss</b>	EN175301-803
<b>Gehäuse</b>	Polyamid (PA6)
<b>ELS</b>	5 A 125 V AC / 3 A 250 V AC

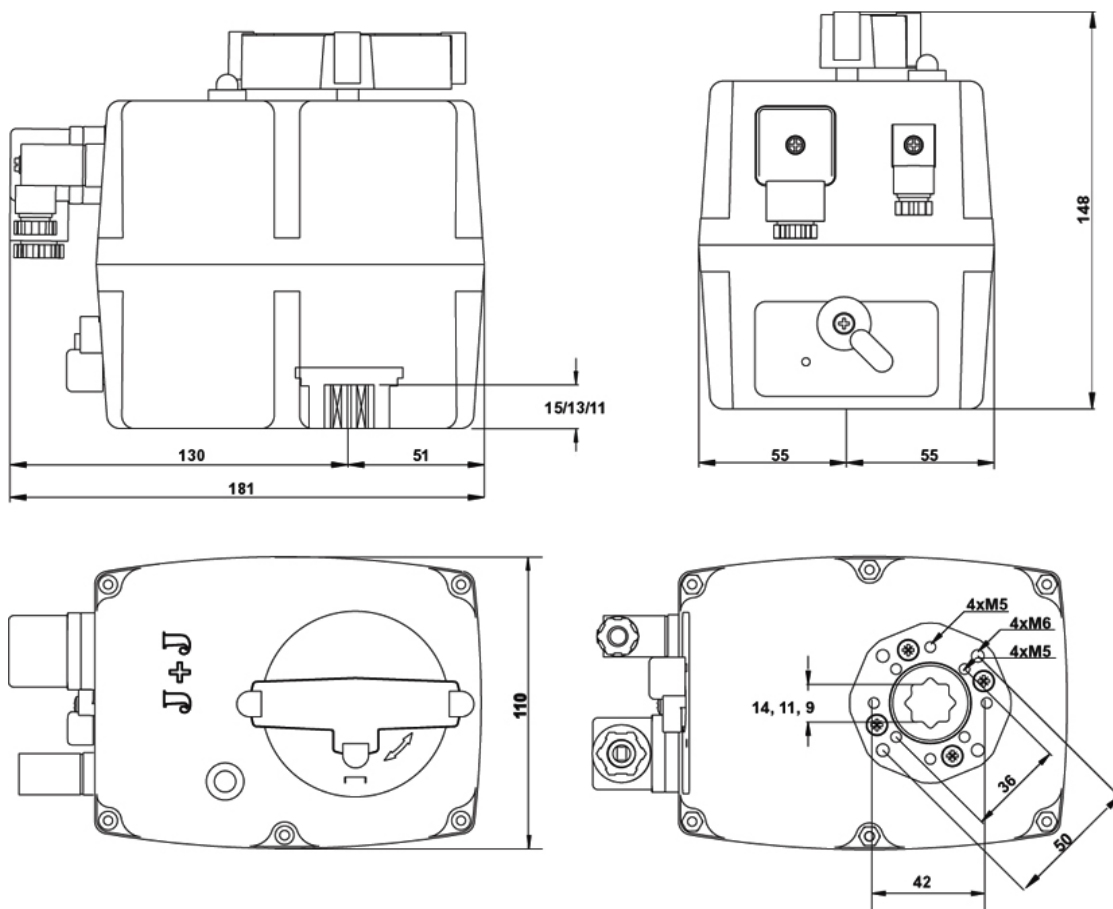
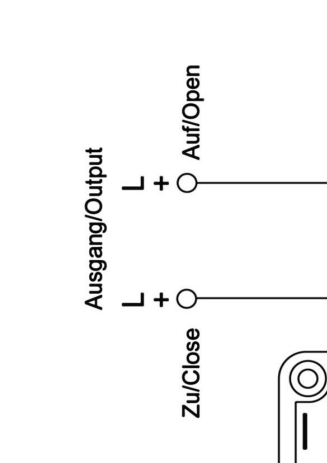
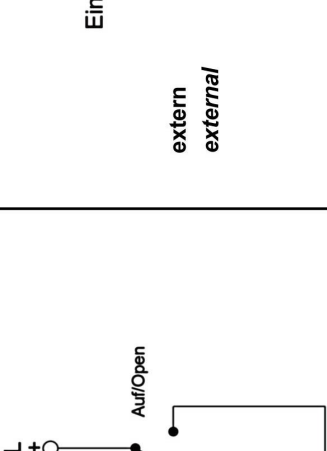
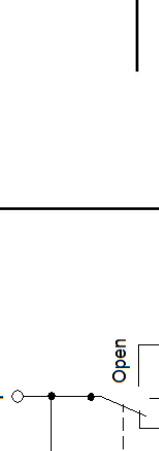
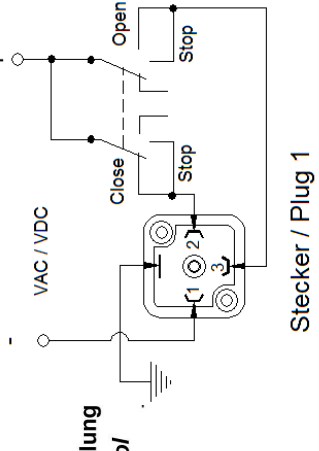

Potentialfreie Endlagen / potentialfree limit switches	
<p><b>Power Standard</b></p> <p>AC/DC 2 Punkt Regelung 2 point control</p> 	 <p>extern external</p>
<p>AC/DC 3 Punkt Regelung 3 point control</p> 	 <p>intern internal</p>
<p>DC 2 Draht 2 wires</p> 