

Up to PL e of EN ISO 13849-1 PNOZ X3P



Safety relay for monitoring E-STOP pushbuttons, safety gates and light beam devices

Approvals

PNOZ X3P	
	◆
	◆
	◆

Unit features

- ▶ Positive-guided relay outputs:
 - 3 safety contacts (N/O), instantaneous
 - 1 auxiliary contact (N/C), instantaneous
- ▶ 1 semiconductor output
- ▶ Connection options for:
 - E-STOP pushbutton
 - Safety gate limit switch
 - Reset button
 - Light barriers
- ▶ LED indicator for:
 - Switch status channel 1/2
 - Supply voltage
- ▶ Semiconductor output signals:
 - Switch status channel 1/2
- ▶ Plug-in connection terminals (either spring-loaded terminal or screw terminal)

Safety features

- The relay meets the following safety requirements:
- ▶ The circuit is redundant with built-in self-monitoring.
 - ▶ The safety function remains effective in the case of a component failure.
 - ▶ The correct opening and closing of the safety function relays is tested automatically in each on-off cycle.

Unit description

The safety relay meets the requirements of EN 60947-5-1, EN 60204-1 and VDE 0113-1 and may be used in applications with

- ▶ E-STOP pushbuttons
- ▶ Safety gates
- ▶ Light beam devices

Block diagram

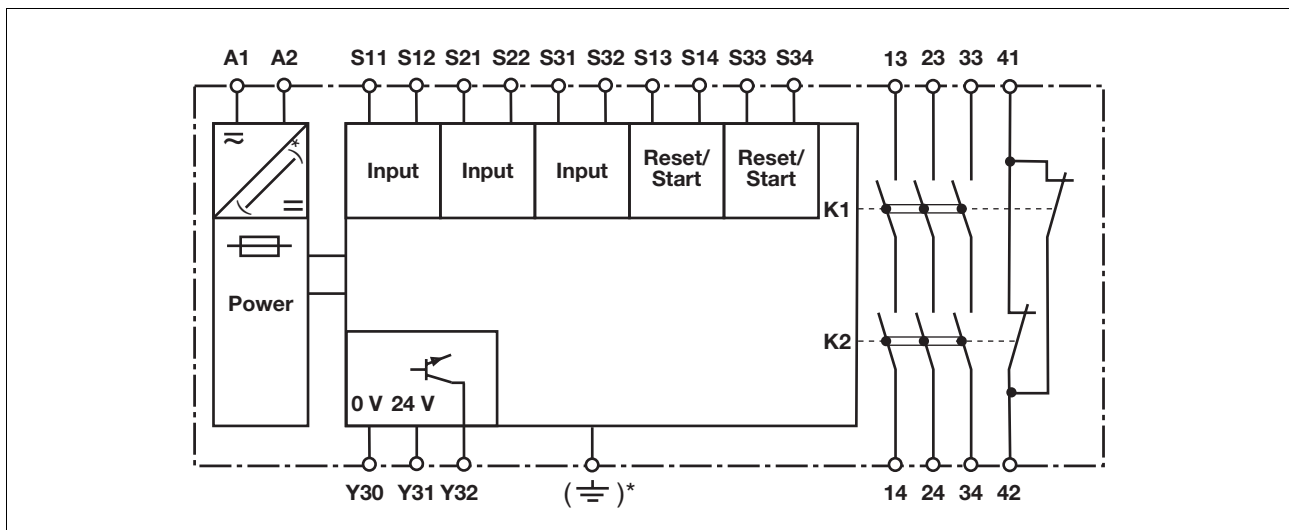

*only with U_B 24 - 240 VAC/DC

Up to PL e of EN ISO 13849-1 PNOZ X3P

Function description

- ▶ Single-channel operation: no redundancy in the input circuit, earth faults in the reset and input circuit are detected.
- ▶ Dual-channel operation without detection of shorts across contacts: redundant input circuit, detects
 - earth faults in the reset and input circuit,
 - short circuits in the input circuit
- ▶ Dual-channel operation with detection of shorts across contacts: redundant input circuit, detects
 - earth faults in the reset and input circuit,
 - short circuits in the input circuit and, with a monitored reset, in the reset circuit too,
 - shorts between contacts in the input circuit.
- ▶ Automatic start: Unit is active once the input circuit has been closed.
- ▶ Monitored reset: Unit is active once the input circuit is closed and once the reset circuit is closed after the waiting period has elapsed (see technical details).
- ▶ Increase in the number of available instantaneous safety contacts by connecting contact expansion modules or external contactors.

Timing diagram

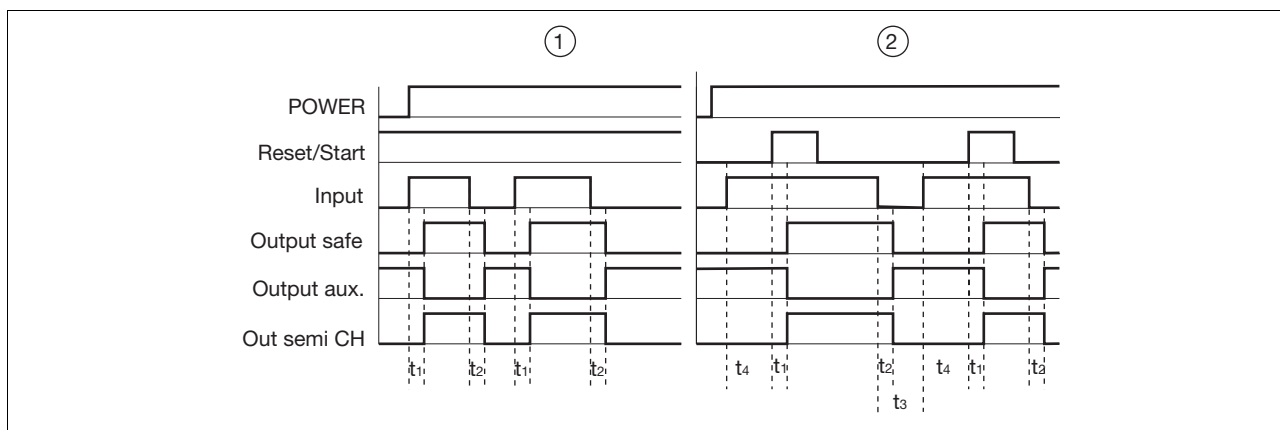

Key

- ▶ Power: Supply voltage
- ▶ Reset/Start: Reset circuit S13-S14, S33-S34
- ▶ Input: Input circuits S11-S12, S21-S22, S31-S32
- ▶ Output safe: Safety contacts 13-14, 23-24, 33-34
- ▶ Output aux: Auxiliary contacts 41-42
- ▶ Out semi CH: Semiconductor output switch status channel 1/2
- ▶ ①: Automatic reset
- ▶ ②: Monitored reset
- ▶ t₁: Switch-on delay
- ▶ t₂: Delay-on de-energisation
- ▶ t₃: Recovery time
- ▶ t₄: Waiting period

Wiring

Please note:

- ▶ Information given in the “Technical details” must be followed.
- ▶ Outputs 13-14, 23-24, 33-34 are safety contacts, output 41-42 is an auxiliary contact (e.g. for display).
- ▶ To prevent contact welding, a fuse should be connected before the output contacts (see technical details).
- ▶ Calculation of the max. cable runs l_{max} in the input circuit:

$$l_{max} = \frac{R_{lmax}}{R_l / km}$$

R_{lmax} = max. overall cable resistance (see technical details)

R_l / km = cable resistance/km

- ▶ Use copper wire that can withstand 60/75 °C.
- ▶ Sufficient fuse protection must be provided on all output contacts with capacitive and inductive loads.

Up to PL e of EN ISO 13849-1 PNOZ X3P

Preparing for operation

► Supply voltage

Supply voltage	AC	DC

► Input circuit

Input circuit	Single-channel	Dual-channel
E-STOP without detection of shorts across contacts		
E-STOP with detection of shorts across contacts		
Safety gate without detection of shorts across contacts		
Safety gate with detection of shorts across contacts		
Light beam device with detection of shorts across contacts via ESPE (not on units with a universal power supply)		

Up to PL e of EN ISO 13849-1 PNOZ X3P

▶ Reset circuit

Reset circuit	E-STOP wiring (single-channel) Safety gate (single-channel)	E-STOP wiring (dual-channel) Safety gate (dual-channel)
Automatic reset		
Monitored reset		

▶ Feedback circuit

Feedback circuit	Automatic reset	Monitored reset
Contacts from external contactors		

▶ Semiconductor output

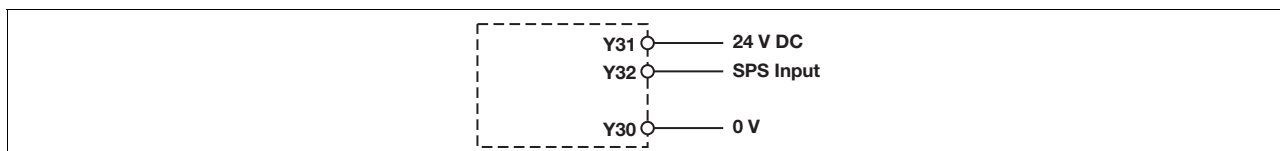

▶ Key

S1/S2	E-STOP/safety gate switch
S3	Reset button
	Switch operated
	Gate open
	Gate closed

Up to PL e of EN ISO 13849-1 PNOZ X3P

Terminal configuration

U_B 24 VAC/DC

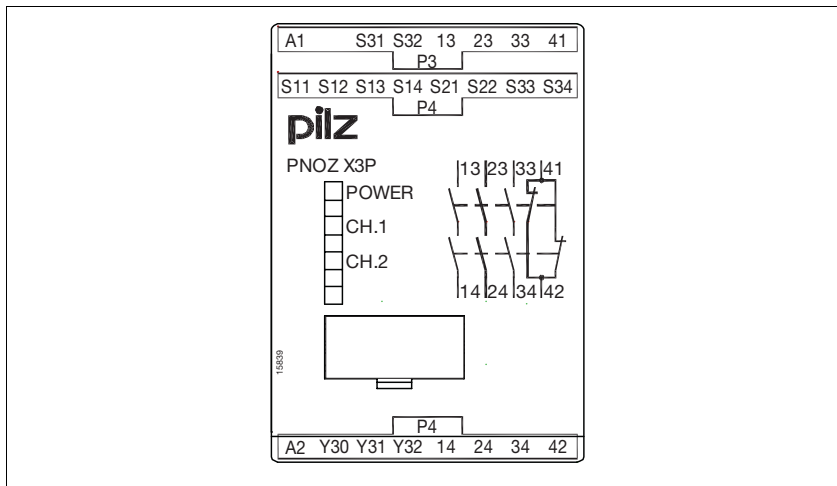

U_B 24 – 240 VAC/DC

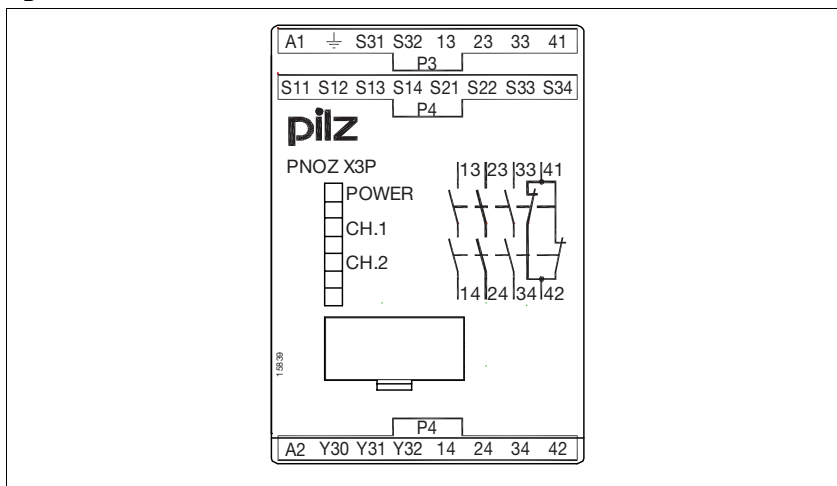

Installation

- ▶ The safety relay should be installed in a control cabinet with a protection type of at least IP54.
- ▶ Use the notch on the rear of the unit to attach it to a DIN rail.
- ▶ Ensure the unit is mounted securely on a vertical DIN rail (35 mm) by using a fixing element (e.g. retaining bracket or an end angle).

Dimensions

* with spring-loaded terminals

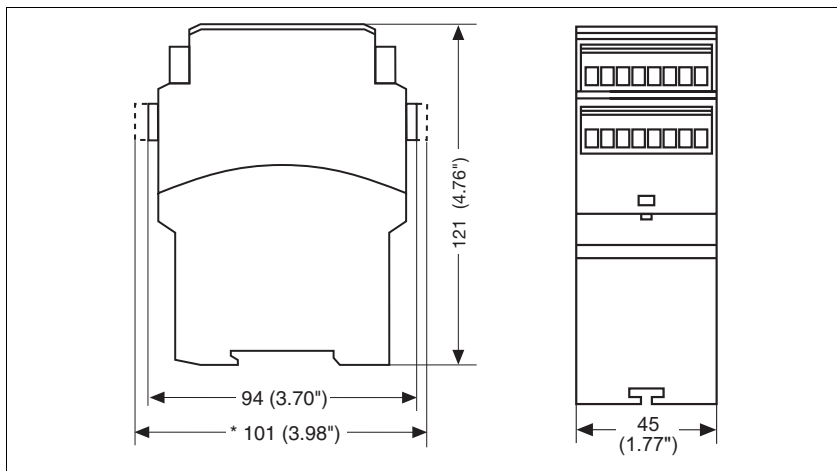

Up to PL e of EN ISO 13849-1 PNOZ X3P

Notice

This data sheet is only intended for use during configuration. For installation and operation, please refer to the operating instructions supplied with the unit.

Service life graph

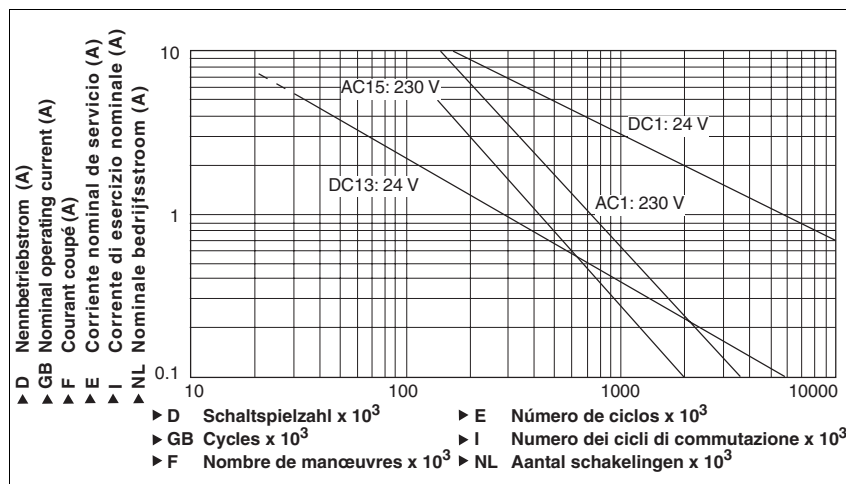

Technical details

Electrical data

Supply voltage	
Supply voltage U _B AC/DC	24 - 240 V, 24 V
Voltage tolerance	-15 %/+10 %
Power consumption at U _B AC	5.0 VA
Power consumption at U _B DC	2.5 W
Frequency range AC	50 - 60 Hz
Residual ripple DC	160 %
Voltage and current at	
Input circuit DC: 24.0 V	35.0 mA Order no.: 777313, 787313 40.0 mA Order no.: 777310, 787310
Reset circuit DC: 24.0 V	50.0 mA Order no.: 777313, 787313 70.0 mA Order no.: 777310, 787310
Feedback loop DC: 24.0 V	20.0 mA
Number of output contacts	
Safety contacts (S) instantaneous:	3
Auxiliary contacts (N/C):	1
Utilisation category in accordance with EN 60947-4-1	
Safety contacts: AC1 at 240 V	I _{min} : 0.01 A , I _{max} : 8.0 A P _{max} : 2000 VA
Safety contacts: DC1 at 24 V	I _{min} : 0.01 A , I _{max} : 8.0 A P _{max} : 200 W
Auxiliary contacts: AC1 at 240 V	I _{min} : 0.01 A , I _{max} : 8.0 A P _{max} : 2000 VA
Auxiliary contacts: DC1 at 24 V	I _{min} : 0.01 A , I _{max} : 8.0 A P _{max} : 200 W
Utilisation category in accordance with EN 60947-5-1	
Safety contacts: AC15 at 230 V	I _{max} : 5.0 A
Safety contacts: DC13 at 24 V (6 cycles/min)	I _{max} : 6.0 A
Auxiliary contacts: AC15 at 230 V	I _{max} : 5.0 A
Auxiliary contacts: DC13 at 24 V (6 cycles/min)	I _{max} : 6.0 A
Contact material	AgSnO2 + 0.2 µm Au

Up to PL e of EN ISO 13849-1 PNOZ X3P

Electrical data	
External contact fuse protection ($I_K = 1 \text{ kA}$) to EN 60947-5-1	
Blow-out fuse, quick	
Safety contacts:	10 A
Auxiliary contacts:	10 A
Blow-out fuse, slow	
Safety contacts:	6 A
Auxiliary contacts:	6 A
Circuit breaker 24 VAC/DC, characteristic B/C	
Safety contacts:	6 A
Auxiliary contacts:	6 A
Semiconductor outputs (short circuit proof)	
External supply voltage	24.0 V DC, 20 mA
Voltage tolerance	24.0 V DC -20 %/+20 %
Max. overall cable resistance R_{lmax} input circuits, reset circuits	
single-channel at U_B DC	150 Ohm Order no.: 777310, 787310 200 Ohm Order no.: 777313, 787313
single-channel at U_B AC	180 Ohm Order no.: 777310, 787310 200 Ohm Order no.: 777313, 787313
dual-channel without detect. of shorts across contacts at U_B DC	300 Ohm Order no.: 777310, 787310 400 Ohm Order no.: 777313, 787313
dual-channel without detect. of shorts across contacts at U_B AC	360 Ohm Order no.: 777310, 787310 400 Ohm Order no.: 777313, 787313
dual-channel with detect. of shorts across contacts at U_B DC	15 Ohm Order no.: 777310, 787310 30 Ohm Order no.: 777313, 787313
dual-channel with detect. of shorts across contacts at U_B AC	30 Ohm
Safety-related characteristic data	
PL in accordance with EN ISO 13849-1	PL e (Cat. 4)
Category in accordance with EN 954-1	Cat. 4
SIL CL in accordance with EN IEC 62061	SIL CL 3
PFH in accordance with EN IEC 62061	2.31E-09
SIL in accordance with IEC 61511	SIL 3
PFD in accordance with IEC 61511	2.03E-06
t_M in years	20
Times	
Switch-on delay	
with automatic reset typ.	250 ms Order no.: 777310, 787310 330 ms Order no.: 777313, 787313
with automatic reset max.	450 ms Order no.: 777313, 787313 500 ms Order no.: 777310, 787310
with automatic reset after power on typ.	280 ms Order no.: 777310, 787310 750 ms Order no.: 777313, 787313
with automatic reset after power on max.	1,000 ms Order no.: 777313, 787313 550 ms Order no.: 777310, 787310
on monitored reset with rising edge typ.	35 ms
on monitored reset with rising edge max.	50 ms
Delay-on de-energisation	
with E-STOP typ.	15 ms Order no.: 777310, 787310 25 ms Order no.: 777313, 787313
with E-STOP max.	30 ms
with power failure typ.	50 ms Order no.: 777310, 787310
with power failure max.	70 ms Order no.: 777310, 787310
with power failure typ. U_B AC/DC: 24 V	150 ms Order no.: 777313, 787313
with power failure max. U_B AC/DC: 24 V	180 ms Order no.: 777313, 787313
787313	
with power failure typ. U_B AC : 240 V	1,500 ms Order no.: 777313, 787313
with power failure max. U_B AC : 240 V	2200 ms Order no.: 777313, 787313

Up to PL e of EN ISO 13849-1 PNOZ X3P

Times	
Recovery time at max. switching frequency 1/s after E-STOP	50 ms
after power failure	100 ms Order no.: 777310, 787310
	200 ms Order no.: 777313, 787313
after power failure on universal power supply	2250 ms Order no.: 777313, 787313
Waiting period with a monitored reset with rising edge	200 ms Order no.: 777313, 787313
	300 ms Order no.: 777310, 787310
Min. start pulse duration with a monitored reset with rising edge	30 ms
Simultaneity, channel 1 and 2	∞
Supply interruption before de-energisation	20 ms
Environmental data	
EMC	EN 60947-5-1, EN 61000-6-2, EN 61000-6-3
Vibration to EN 60068-2-6	
Frequency	10 - 55 Hz
Amplitude	0.35 mm
Climatic suitability	EN 60068-2-78
Airgap creepage in accordance with EN 60947-1	
Pollution degree	2
Overvoltage category	III
Rated insulation voltage	250 V
Rated impulse withstand voltage	4.0 kV
Ambient temperature	-20 - 55 °C
Storage temperature	-40 - 85 °C
Protection type	
Mounting (e.g. cabinet)	IP54
Housing	IP40
Terminals	IP20
Mechanical data	
Housing material	
Housing	PPO UL 94 V0
Front	ABS UL 94 V0
Cross section of external conductors with screw terminals	
1 core flexible	0.25 - 2.50 mm², 24 - 12 AWG Order no.: 777310, 777313
2 core, same cross section, flexible:	
with crimp connectors, without insulating sleeve	0.25 - 1.00 mm², 24 - 16 AWG Order no.: 777310, 777313
without crimp connectors or with TWIN crimp connectors	0.20 - 1.50 mm², 24 - 16 AWG Order no.: 777310, 777313
Torque setting with screw terminals	0.50 Nm Order no.: 777310, 777313
Cross section of external conductors with spring-loaded terminals: Flexible with/without crimp connectors	0.20 - 1.50 mm², 24 - 16 AWG Order no.: 787310, 787313
Spring-loaded terminals: Terminal points per connection	2 Order no.: 787310, 787313
Stripping length	8 mm Order no.: 787310, 787313
Dimensions	
Height	101.0 mm Order no.: 787310, 787313
	94.0 mm Order no.: 777310, 777313
Width	45.0 mm
Depth	121.0 mm
Weight	270 g Order no.: 787310
	280 g Order no.: 777310
	300 g Order no.: 787313
	310 g Order no.: 777313

The standards current on **2007-09** apply.

Up to PL e of EN ISO 13849-1 PNOZ X3P

Conventional thermal current

Number of contacts	I_{th} (A) at U_B DC	I_{th} (A) at U_B AC
1	8.00 A	8.00 A
2	7.00 A Order no.: 777313, 787313 8.00 A Order no.: 777310, 787310	7.00 A
3	6.00 A Order no.: 777313, 787313 7.00 A Order no.: 777310, 787310	6.00 A

Order reference

Type	Features	Terminals	Order no.
PNOZ X3P C	24 VAC/DC	Spring-loaded terminals	787 310
PNOZ X3P	24 VAC/DC	Screw terminals	777 310
PNOZ X3P C	24 - 240 VAC/DC	Spring-loaded terminals	787 313
PNOZ X3P	24 - 240 VAC/DC	Screw terminals	777 313