

# JISKOOT MS53 LabMix

## Laboratory sample mixing system

### APPLICATIONS

- Onsite sample mixing

### ADVANTAGES

- Pneumatically driven or electrical pumped loop for ensuring thorough sample mixing
- Keyed connectors to prevent operator errors
- Direct deposition into laboratory glassware or analyzers
- Interfacing with other sample receivers

Accurate sampling requires that the integrity of the sample be maintained at each step of the sampling process. Receivers, mixing systems, and procedures are specifically chosen based on the type of fluid that is being sampled. The JISKOOT MS53 LabMix\* laboratory sample mixing system provides a controlled and accurate solution.

Once a sample is collected in a portable receiver, it may be many hours before it is analyzed. During this time, the heavier components, such as water, will fall out and separate. To ensure that the sample withdrawn for analysis is representative, the contents must be thoroughly mixed. The JISKOOT MS53 LabMix system provides an electrical or pneumatically driven pumped loop to perform this function. The system is designed to be situated on a laboratory bench with the receivers placed on the floor. Samples may be drawn from a takeoff valve or through an optional septum. The mixer can also be mounted in a heated enclosure to mix temperature-critical oils.

### Method of operation

The laboratory mixer consists of a pump-driven loop that draws fluid from the lowest point of the receiver, pumping it through a static mixer and returning it back to the receiver. When returning the fluid back into the receiver, internal spray bar jets sweep the wall and base to induce swirl. A takeoff valve is provided to draw off the mixed sample and deposit it directly into laboratory glassware. An optional septum can be provided to enable a syringe to draw off fluid directly from the mixing loop for use with lab analyzers. Typical mixing times range from 5 to 20 minutes, depending on the sample volume and type of oil. The JISKOOT MS53 LabMix system is fitted with keyed connectors to help prevent spillage and operator errors. Additionally, adapters can be supplied to allow interconnection with other sample receivers.



*JISKOOT MS53 LabMix laboratory sample mixing system.*

# JISKOOT MS53 LabMix

## JISKOOT MS53 LabMix System Specifications

Fluids	Crude oil, condensates, and refined products	
Pump	Direct coupled with integral relief valve, 5 galUS/min [20 L/min]	
Driver—electrical	0.5-hp, flameproof and explosion proof, supplied complete with switch, single phase, or three phase	
Driver—pneumatic	Air motor with regulator and silencer, 15 ft <sup>3</sup> /min at 40 psi [25 L at 2.75 bar]	
Mixer	Typically six ¼-in elements (depends on viscosity range)	
Viscosity, cS	1 to 500 (extended viscosity range available on request)	
Connections	Hoses	Nitrile-rubber-lined hydraulic; supplied 5 ft [1.5 m] (can be cut to suit)
	Inlet	¾-in female Q-R coupling
	Outlet	½-in female Q-R coupling
	Drawoff(s)	¼-in valve (optional septum)
Standard fittings	Integral relief valve	
Dimensions, in [mm]	11 × 22½ × 14 [280 × 570 × 363]	
Weight, lbm [kg]	83 [37.5]	
Certification	ATEX Eex d IIC T3	
	UL FM Class I Div. 1 Group D	

*SW: Not sure how this should be worded. Is it always with a switch that enables the customer to use either two-phase or three-phase power? or is the choice switch or single-phase power or three-phase power?*

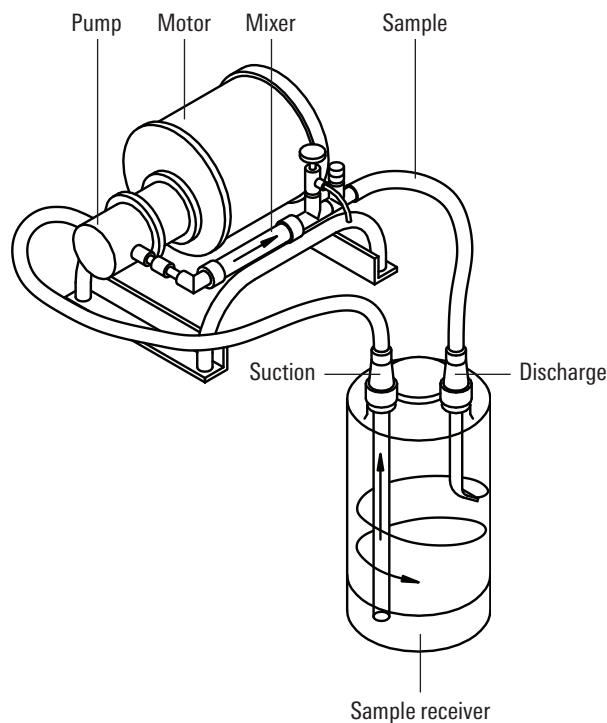

[products.slb.com/measurement](https://products.slb.com/measurement)