

PTC-Resistor Temperature-Sensors MINIKA®

to DIN 44 081 and DIN 44 082

General

PTC-resistor temperature sensors (also called PTC-resistors or thermistors) are temperature dependent semiconductor resistors whose main function is to alter their electrical resistance drastically when their body temperature reaches the nominal trip temperature NAT (TNF)

PTC-resistors are used principally to protect windings in electromotors or transformers against excess temperature. They also find application in machines, tooling machines especially machine bearings and controlling the temperature of power semiconductors.

PTC-resistor temperature sensors are particularly suited to this purpose due to their precise response range combined with small dimensions and minimal thermal inertia at low cost.

Single PTC-resistor type MINIKA® K

PTFE-insulated strand
Cu, silver-plated
Lead length: 500 ±10 mm
Stripping of lead-ends 10 mm
standard cross-section:
0,14 mm² (AWG 26)
weight: approx. 2,6 g

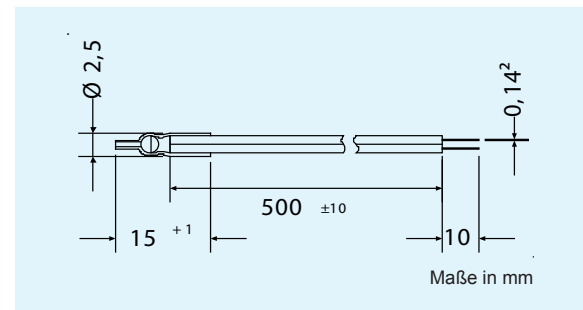

Type	NAT°C	Standard ID colour (DIN 44 081)	Order-no. MINIKA®
K60	60 ± 5	white - grey	K401000
K70	70 ± 5	white - brown	K401010
K 80	80 ± 5	white - white	K401005
K 90	90 ± 5	green - green	K401015
K100	100 ± 5	red - red	K401025
K110	110 ± 5	brown - brown	K401035
K120	120 ± 5	grey - grey	K401045
K130	130 ± 5	blue - blue	K401055
K140	140 ± 5	white - blue	K401065
K150	150 ± 5	black - black	K401075
K160	160 ± 5	blue - red	K401085
K170	170 ± 5	white - green	K401095
K 180	180 ± 5	white - red	K401090

Triple PTC-resistor type MINIKA® KD

PTFE-insulated strand
 Cu, silver-plated
 Lead length:
 500-180-180-500 ± 10 mm
 Stripping of lead ends 10 mm
 standard cross-section:
 0.14 mm² (AWG 26)
 weight: approx. 3,6 g

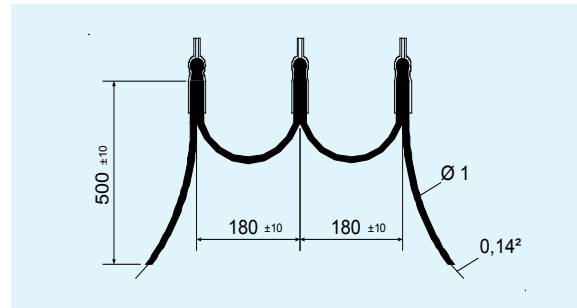
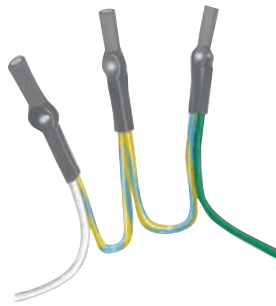

Type	NAT°C	Standard ID colour (DIN 44 082)	Order-no. MINIKA®
KD60	60 ± 5	white - yellow - yellow - grey	K401300
KD70	70 ± 5	white - yellow - yellow - brown	K401310
KD80	80 ± 5	white - yellow - yellow - white	K401305
KD90	90 ± 5	green - yellow - yellow - green	K401315
KD100	100 ± 5	red - yellow - yellow - red	K401325
KD110	110 ± 5	brown - yellow - yellow - brown	K401335
KD120	120 ± 5	grey - yellow - yellow - grey	K401345
KD130	130 ± 5	blue - yellow - yellow - blue	K401355
KD140	140 ± 5	white - yellow - yellow - blue	K401365
KD150	150 ± 5	black - yellow - yellow - black	K401375
KD160	160 ± 5	blue - yellow - yellow - red	K401385
KD170	170 ± 5	white - yellow - yellow - green	K401395
KD180	180 ± 5	white - yellow - yellow - red	K401390

Screw-in sensors in housing G2 (M4) and G3 (M6) MINIKA® KS

PTFE-insulated strand
 Cu, silver-plated
 Lead length:
 500 ± 10 mm
 Stripping of lead ends 10 mm
 standard cross-section:
 0.14 mm² (AWG 26)
 weight: G2: approx. 5 g
 G3: approx. 14 g

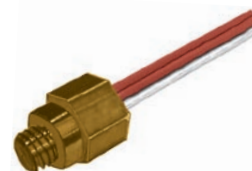
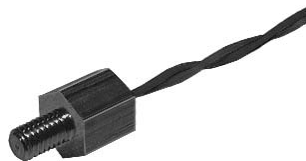

Type	NAT°C	Standard ID colour DIN (44 081)	Order-numbers	
			G2 (M4)	G3 (M6)
KS80	80 ± 5	white - white	K302005	K302109
KS90	90 ± 5	green - green	K302015	K302119
KS100	100 ± 5	red - red	K302025	K302129
KS110	110 ± 5	brown - brown	K302035	K302139
KS120	120 ± 5	grey - grey	K302045	K302149
KS130	130 ± 5	blue - blue	K302055	K302159
KS140	140 ± 5	white - blue	K302065	K302169
KS150	150 ± 5	black - black	K302075	K302179
KS160	160 ± 5	blue - red	K302085	K302189
KS170	170 ± 5	white - green	K302095	K302199
KS180	180 ± 5	white - red	K302090	K302190

Technical Data

Design	K	KD	KS
Max. operational voltage	25 V DC	25 V DC	25 V DC
Measuring voltage at NAT+15K -20...NAT+5K	≤ 7,5 V DC ≤ 2,5 V DC	≤ 7,5 V DC ≤ 2,5 V DC	≤ 7,5 V DC ≤ 2,5 V DC
Nominal response temperature NAT (TNF)	60...180°C	60...180°C	80...180°C
Tolerance NAT	± 5 K	± 5 K	± 5 K
Nominal resistance R at -20...NAT-20K VPTC ≤ 2,5 V	≤ 250 Ω	≤ 750 Ω	≤ 250 Ω
Rated ambient temperature range	-20°C...NAT+20°C		
Thermal response-time t_a	≤ 5 s	≤ 5 s	-
Storage temperature	-25°C...+65°C		
Rated insulation voltage U_{eff}	690 V	690 V	690 V
Test voltage U_{eff}	2500 V AC	2500 V AC	2500 V AC

1

Resistors

The resistance of each individual sensor (according to standard) must, for temperatures related to the Nominal Response Temperature (NAT), have the following values:

- ≤ 250 Ohms at temperatures of -20°C to NAT -20 degrees. Measurement voltage up to max. 2.5 V
- ≤ 550 Ohms at a temperature of NAT -5 degrees. Measurement voltage max. 2.5 V
- ≥ 1330 Ohms at a temperature of NAT +5 degrees. Measurement voltage max. 2.5 V
- ≥ 4000 Ohms at a temperature of NAT +15 degrees. Measurement voltage max. 7.5 V

The exact values of the resistance values in the temperature ranges are not relevant. Flawless sensors should have a cold resistance of between 20 and at most 250 Ohms. Typical values (ambient temperature) lie between 50 - 150 Ohms.

When the cold resistance is within these limits, short-circuit and interruption can be excluded. For checking the nominal response temperature, the sensors have to be heated up to this temperature.

In accordance with standards, trip devices switch between 1650 Ohms and 4000 Ohms.

If a varying number of temperature sensors connected in series to a trip device are subjected to uniform heat, this results in the following cut-off point:

- 1 PTC switches at latest at NAT +15 degrees, at earliest at NAT +5 degrees.
- 3 PTC (typical instance) switch at latest at NAT +5 degrees, at earliest at NAT -5 degrees.
- 6 PTC switch at latest at NAT, at earliest at NAT -20 degrees. (Absolutely uniform heating of all sensors virtually never occurs in this instance).

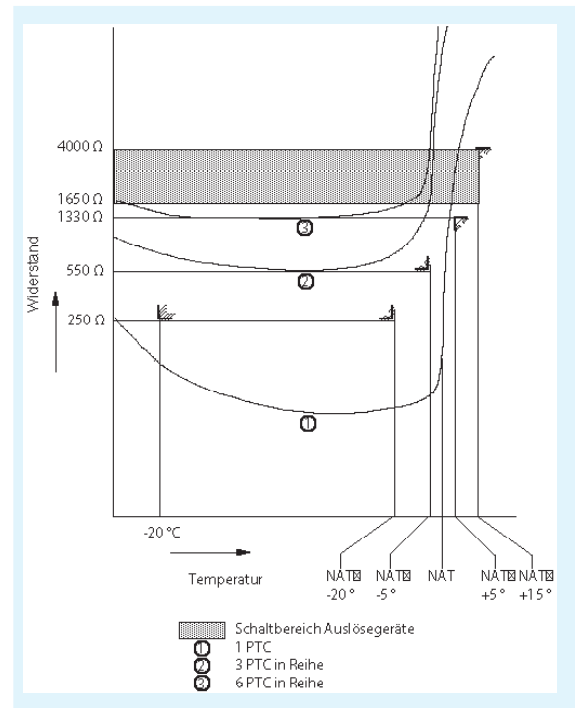

Insulation classes

For built-in PTC-resistors, we recommend the following nominal cut-off temperature values for machines which are used to full capacity within permissible heating limits in keeping with their insulation class (VDE 0530).

These values can then be correspondingly reduced for machines at less than full capacity. In some instances it might prove necessary to work out nominal response temperature values which deviate somewhat from

the values recommended in the table, on the basis of trial and error. When it is intended as a preliminary warning, the value recommended as nominal response temperature is 20°C below the break temperature.

Insulation material class			
120 (E)	130 (B)	155 (F)	180 (H)
120°C	130°C	150°C	

Fitting PTC-resistor temperature sensors

PTC-resistors can only be fitted before a winding has been impregnated by the motor manufacturer. It is not possible to insert them at a later stage.

Each winding has a sensor of its own. This means fitting 3 in single-speed motors and 6 in pole changing motors, with these sensors arranged in series and taken to separate terminals in the terminal box.

Measuring circuit must be provided with a separate power supply. The use of motor supply lines or other main current lines is unacceptable. Shielded supply lines must be used in case inductive or capacitive interference is produced by nearby high-voltage lines.

The maximum line length for a cable diameter of 0.5 mm² is approx. 500 m. For greater diameter cable, correspondingly more.

Fitting should, where possible, be carried out at the warmest winding head in the exhausted-air-side of the electrical machine. Care should be taken to ensure good heat contact between the sensors and the winding when being fitted. The more intimate the connection between a PTC-resistor and its winding, the better the winding temperature is registered, especially when temperatures rise sharply. For this reason, Temperature sensors should be implanted in the middle of the end winding-heads so as to be surrounded on all sides by the winding copper.

To fit the temperature sensors, the ready-shaped winding heads are spread apart in the centre using a piece of winding wood. The temperature sensors should be inserted parallel to the winding wires, care being taken that the winding wires are actually touching the temperature sensors. Cavities and air-occlusions impair heat contact and can be minimized by exerting pressure by hand to close the gap between winding wires and sensors. At the spot where the sensors are to be fitted, the winding wires on the end winding should be tightly bandaged. If the wire is more than 1 mm² thick, intervening spaces should be filled in with resin thickened with quartz powder.

If the motor manufacturer uses special saturants or impregnating resins whose chemical behaviour is anything but neutral, or if he uses some special working method, he will have to test the temperature sensors' resistivity himself in the operating conditions he will use.

To prevent peaks in interference voltage due to the formation of loops, we recommend that the connecting strand be fed back on the same side as the lead.

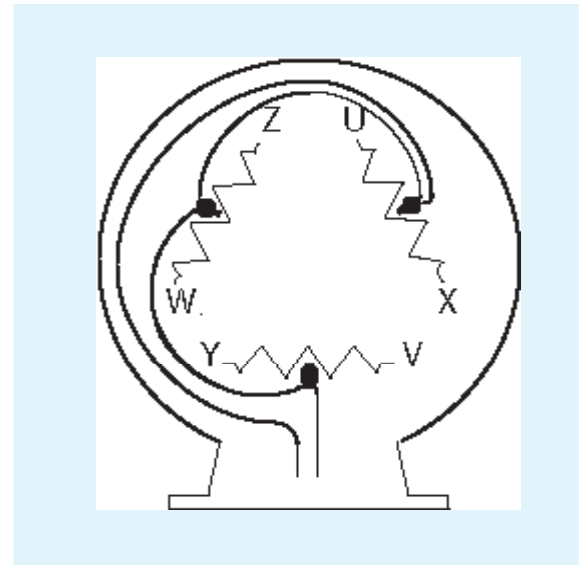

Assembly Tip: Do not shorten leads which are too long, roll them up and fasten them in position.

Testing fitted PTC-resistors

A maximum DC-voltage of 2.5 V can be passed through PTC-resistor temperature sensors when testing. Buzzers (voltage peaks) and similar testers should, therefore, not be used, but only meters or bridges.

For all measurement voltage values up to DC 2.5 V, resistance

values ranging from -20°C to NAT -20 degrees should not exceed 250 Ohms. Exact resistance values within this temperature range are unimportant. For flawless sensors, the lowest resistance value is generally above 20 Ohms.

When measurement values are being determined, care must be taken that the measurement results are not influenced by the selfwarming of the sensors. In the course of the manufacturing process, we test all sensors for NAT and disruptive strength.

Technical Data

Limit Values

Max. perm. operational voltage	U _{max.} 30 V
Max. perm. PTC-resistor temp.	T _{max.} 200°C
Max. perm. top temperature	T _{max.*} 210°C for 12 h
Test voltage (Strand against insulation) also for screwable sensors	2.5 kV

Characteristic Values

Measuring voltage below NAT +5°C	max. DC 2.5 V
Leads	silvered copper strand with PTFE teflon insulation
Stripping of lead ends	approx. 10 mm, twisted
Dielectric strength of leads	AC 660 V _{eff} , permanent
Shrink-tube	Kynar, approx. 15 mm
Donut diameter	3.5 mm (2.5 mm for MINIKA)
Thermal sensor time constant	approx. 2.5 - 3.5 sec (MINIKA < 2 sec)

Mechanical Data

Lead length	Single PTC-resistor 500 mm ± 10 mm (standard) Double PTC-resistor 500-180-500 mm ± 10 mm (standard) Triple PTC-resistor 500-180-180-500 mm ± 10 mm (standard) Oil immersed single PTC-resistor 1200 mm ± 10 mm Other connection lengths are available on request.
Lead cross-section	0.14 mm ² for single, double and triple PTC-resistors 0.75 mm ² for oil immersed single PTC-resistors
Standard identification colour	see table
Nominal response temperature	60°C...180°C

Special designs are available on request.