



SERVICE MANUAL

6.5 MCG 60HZ | 5.2 MCG 50HZ

5.0 MCG 60HZ | 4.2 MCG 50HZ

Multi-port ELECTRONIC FUEL INJECTION
MARINE GASOLINE GENERATOR

Single Phase

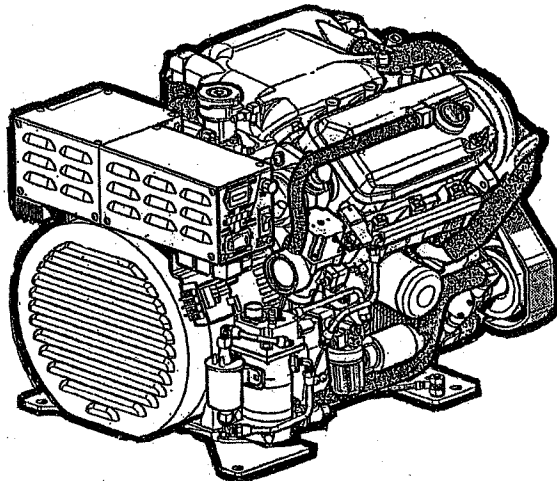

PUBLICATION #055743
JULY 2014 REVISION 0



Low Carbon Monoxide Emissions

**CALIFORNIA PROPOSITION 65
WARNING**

Exhaust gas from diesel and gasoline engines (and some of its constituents) are known to the State of California to cause cancer, birth defects, and other reproductive harm.

 **WARNING:**

Exhaust gasses contain Carbon Monoxide, an odorless and colorless gas. Carbon Monoxide is poisonous and can cause unconsciousness and death. Symptoms of Carbon Monoxide exposure can include:

- Dizziness
- Nausea
- Headache
- Weakness and Sleepiness
- Throbbing in Temples
- Muscular Twitching
- Vomiting
- Inability to Think Coherently

IF YOU OR ANYONE ELSE EXPERIENCE ANY OF THESE SYMPTOMS, GET OUT INTO THE FRESH AIR IMMEDIATELY. If symptoms persist, seek medical attention. Shut down the unit and do not restart until it has been inspected and repaired.

A WARNING DECAL is provided by WESTERBEKE and should be fixed to a bulkhead near your engine or generator.

WESTERBEKE also recommends installing CARBON MONOXIDE DETECTORS in the living/sleeping quarters of your vessel. They are cost affective and easily obtainable at your local marine store.



Low Carbon Monoxide Emissions

SAFETY INSTRUCTIONS

INTRODUCTION

Read this safety manual carefully. Most accidents are caused by failure to follow fundamental rules and precautions. Know when dangerous conditions exist and take the necessary precautions to protect yourself, your personnel, and your machinery.

The following safety instructions are in compliance with the American Boat and Yacht Council (ABYC) standards.

PREVENT ELECTRIC SHOCK

⚠ WARNING: Do not touch AC electrical connections while engine is running. Lethal voltage is present at these connections!

- Do not operate this machinery without electrical enclosures and covers in place.
- Shut off electrical power before accessing electrical equipment.
- Use insulated mats whenever working on electrical equipment.
- Make sure your clothing and skin are dry, not damp (particularly shoes) when handling electrical equipment.
- Remove wristwatch and all jewelry when working on electrical equipment.

PREVENT BURNS — HOT ENGINE

⚠ WARNING: Do not touch hot engine parts or exhaust system components. A running engine gets very hot!

- Monitor engine antifreeze coolant level at the plastic coolant recovery tank and periodically at the filler cap location on the water jacketed exhaust manifold, but only when the engine is COLD.

⚠ WARNING: Steam can cause injury or death!

- In case of an engine overheat, allow the engine to cool before touching the engine or checking the coolant.

PREVENT BURNS — FIRE

⚠ WARNING: Fire can cause injury or death!

- Prevent flash fires. Do not smoke or permit flames or sparks to occur near the carburetor, fuel line, filter, fuel pump, or other potential sources of spilled fuel or fuel vapors. Use a suitable container to catch all fuel when removing the fuel line, carburetor, fuel filters, or other fuel system components.
- Do not operate with the air cleaner/silencer or flame arrester screen removed. Backfire can cause severe injury or death.
- Do not smoke or permit flames or sparks to occur near the fuel system. Keep the compartment and the engine/generator clean and free of debris to minimize the chances of fire. Wipe up all spilled fuel and engine oil.
- Be aware — Diesel fuel will burn.

PREVENT BURNS — EXPLOSION

⚠ WARNING: Explosions from fuel vapors can cause injury or death!

- Follow re-fueling safety instructions. Keep the vessel's hatches closed when fueling. Open and ventilate cabin after fueling. Check below for fumes/vapor before running the blower. Run the engine compartment blower prior to starting, follow the recommendation of the vessel builder.
- All fuel vapors are highly explosive. Use extreme care when handling and storing fuels. Store fuel in a well-ventilated area away from spark-producing equipment and out of the reach of children.
- Do not fill the fuel tank(s) while the engine is running.
- Shut off the fuel service valve at the engine when servicing the fuel system. Take care in catching any fuel that might spill. DO NOT allow any smoking, open flames, or other sources of fire near the fuel system or engine when servicing. Ensure proper ventilation exists when servicing the fuel system.
- Do not alter or modify the fuel system.
- Be sure all fuel supplies have a positive shutoff valve.
- Be certain fuel line fittings are adequately tightened and free of leaks.
- Make sure a fire extinguisher is installed nearby and is properly maintained. Be familiar with its proper use. Extinguishers rated ABC by the NFPA are appropriate for all applications encountered in this environment.

SAFETY INSTRUCTIONS

ACCIDENTAL STARTING

 **WARNING: Accidental starting can cause injury or death!**

- Disconnect the battery cables before servicing the engine/generator. Remove the negative lead first and reconnect it last.
- Make certain all personnel are clear of the engine before starting.
- Make certain all covers, guards, and hatches are re-installed before starting the engine.

BATTERY EXPLOSION

 **WARNING: Battery explosion can cause injury or death!**

- Do not smoke or allow an open flame near the battery being serviced. Lead acid batteries emit hydrogen, a highly explosive gas, which can be ignited by electrical arcing or by lit tobacco products. Shut off all electrical equipment in the vicinity to prevent electrical arcing during servicing.
- Never connect the negative (-) battery cable to the positive (+) connection terminal of the starter solenoid. Do not test the battery condition by shorting the terminals together. Sparks could ignite battery gases or fuel vapors. Ventilate any compartment containing batteries to prevent accumulation of explosive gases. To avoid sparks, do not disturb the battery charger connections while the battery is being charged.
- Avoid contacting the terminals with tools, etc., to prevent burns or sparks that could cause an explosion. Remove wristwatch, rings, and any other jewelry before handling the battery.
- Always turn the battery charger off before disconnecting the battery connections. Remove the negative lead first and reconnect it last when servicing the battery.

BATTERY ACID

 **WARNING: Sulfuric acid in batteries can cause severe injury or death!**

- When servicing the battery or checking the electrolyte level, wear rubber gloves, a rubber apron, and eye protection. Batteries contain sulfuric acid which is destructive. If it comes in contact with your skin, wash it off at once with water. Acid may splash on the skin or into the eyes inadvertently when removing electrolyte caps.

TOXIC EXHAUST GASES

 **WARNING: Carbon monoxide (CO) is a deadly gas!**

- Ensure that the exhaust system is adequate to expel gases discharged from the engine. Check the exhaust system regularly for leaks and make sure the exhaust manifold/water-injected elbow is securely attached.
- Be sure the unit and its surroundings are well ventilated. Run blowers when running the generator set or engine.
- Do not run the generator set or engine unless the boat is equipped with a functioning marine carbon monoxide detector that complies with ABYC A-24. Consult your boat builder or dealer for installation of approved detectors.
- For additional information, refer to ABYC TH-22 (educational information on Carbon Monoxide).

 **WARNING: Carbon monoxide (CO) is an invisible odorless gas. Inhalation produces flu-like symptoms, nausea or death!**

- Do not use copper tubing in diesel exhaust systems. Diesel fumes can rapidly destroy copper tubing in exhaust systems. Exhaust sulfur causes rapid deterioration of copper tubing resulting in exhaust/water leakage.
- Do not install exhaust outlet where exhaust can be drawn through portholes, vents, or air conditioners. If the engine exhaust discharge outlet is near the waterline, water could enter the exhaust discharge outlet and close or restrict the flow of exhaust. Avoid overloading the craft.
- Although diesel engine exhaust gases are not as toxic as exhaust fumes from gasoline engines, carbon monoxide gas is present in diesel exhaust fumes. Some of the symptoms or signs of carbon monoxide inhalation or poisoning are:

Vomiting	Inability to think coherently
Dizziness	Throbbing in temples
Headache	Muscular twitching
Nausea	Weakness and sleepiness

AVOID MOVING PARTS

 **WARNING: Rotating parts can cause injury or death!**

- Do not service the engine while it is running. If a situation arises in which it is absolutely necessary to make operating adjustments, use extreme care to avoid touching moving parts and hot exhaust system components.

SAFETY INSTRUCTIONS

- Do not wear loose clothing or jewelry when servicing equipment; tie back long hair and avoid wearing loose jackets, shirts, sleeves, rings, necklaces or bracelets that could be caught in moving parts.
- Make sure all attaching hardware is properly tightened. Keep protective shields and guards in their respective places at all times.
- Do not check fluid levels or the drive belt's tension while the engine is operating.
- Do not allow any swimming or activity around or near the exhaust discharge opening for the generator while the generator is operating. Carbon Monoxide poisoning or death can occur.

HAZARDOUS NOISE

⚠ WARNING: High noise levels can cause hearing loss!

- Never operate an engine without its muffler installed.
- Do not run the engine with the air intake (silencer) or flame arrester removed.
- Do not run engines for long periods with their enclosures open (when installed).

⚠ WARNING: Do not work on machinery when you are mentally or physically incapacitated by fatigue!

OPERATORS MANUAL

Many of the preceding safety tips and warnings are repeated in your Operators Manual along with other cautions and notes to highlight critical information. Read your manual carefully, maintain your equipment, and follow all safety procedures.

GASOLINE ENGINE AND GENERATOR INSTALLATIONS

Preparations to install a gasoline engine or generator should begin with a thorough examination of the American Boat and Yacht Council's (ABYC) standards. These standards are from a combination of sources including the USCG and the NFPA.

Sections of the ABYC standards of particular interest are:

H-2 Ventilation for Boats using Gasoline

H-24 Gasoline Fuel Systems

P-1 Installation of Exhaust Systems

for Propulsion and Auxiliary Engines

P-4 Marine Inboard Engines and Transmissions

E1 AC and DC Electrical Systems on Boats

All installations must comply with the Federal Code of Regulations (FCR).

www.abycinc.org

ABYC, NFPA AND USCG PUBLICATIONS FOR INSTALLING ENGINES AND GENERATORS

Read the following ABYC, NFPA and USCG publications for safety codes and standards. Follow their recommendations when installing your engine.

ABYC (American Boat and Yacht Council)
"Standards and Technical Information Reports for Small Craft"

Order from:

ABYC
613 Third Street, Suite 10
Annapolis, MD 21403
www.abycinc.org

NFPA (National Fire Protection Association)
"Fire Protection Standard for Motor Craft"

Order from:

NFPA
11 Tracy Drive
Avon Industrial Park
Avon, MA 02322

USCG (United States Coast Guard)
"USCG 33CFR183"

Order from:

U.S. Government Printing Office
Washington, D.C. 20404

INSTALLATION

When installing WESTERBEKE engines and generators it is important that strict attention be paid to the following information:

CODES AND REGULATIONS

Strict federal regulations, ABYC guidelines, and safety codes must be complied with when installing engines and generators in a marine environment.

SIPHON-BREAK

For installations where the exhaust manifold/water injected exhaust elbow is close to or will be below the vessel's waterline, provisions must be made to install a siphon-break in the raw water supply hose to the exhaust elbow. This hose must be looped a minimum of 20" above the vessel's waterline. *Failure to use a siphon-break when the exhaust manifold/water injected exhaust elbow is near or below the loaded water line of the vessel will result in raw water damage to the engine and possible flooding of the vessel.*

If you have any doubt about the position of the water-injected exhaust elbow relative to the vessel's waterline under the vessel's various operating conditions, *install a siphon-break.*

NOTE: *A siphon-break requires periodic inspection and cleaning to ensure proper operation. Failure to properly maintain a siphon-break can result in catastrophic engine damage. Consult the siphon-break manufacturer for proper maintenance.*

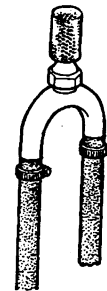

AVAILABLE FROM
YOUR WESTERBEKE
DEALER

SIPHON-BREAK WITH STAINLESS
LOOP

EXHAUST SYSTEM

The exhaust system's hose **MUST** be certified for marine use. Corrugated Marine Exhaust Hose is recommended. The use of this type of hose allows for extreme bends and turns without the need of additional fitting and clamps to accomplish these bends and turns. In this regard, a single length of corrugated exhaust hose can be used. The system **MUST** be designed to prevent the entry of water into the exhaust system under any sea conditions and at any angle of vessels heel.

A detailed Marine Installation Manual covering gasoline and diesel engines and generators is supplied with every unit sold. This manual is also available in pdf format on our website to download

Website: www.westerbeke.com

CARBON MONOXIDE "CO"/LOW-CO GENERATORS

IMPORTANT INFORMATION

DESCRIPTION

Carbon monoxide "CO" is a component of engine exhaust. It is a colorless, tasteless, odorless, lighter than air poisonous gas that can kill you without any warning. CO poisoning is one of the major safety risks associated with boating. It is a threat that must not be underestimated.

Westerbeke Low-CO generators are designed to dramatically reduce normal levels of CO in the engine exhaust.

Several standards for CO have been published, expressed in parts per million "ppm" and hours of exposure:

Regulator	CO ppm	Exposure Hours
EPA	9	8
ACGIH	25	8
EPA	35	1
NIOSH	35	8
OSHA	50	8
ACGIH	125	0.5
NIOSH	200	0.0
NIOSH (IDLH)	1200	0.0

1200 ppm is the so-called IDLH concentration - IMMEDIATELY DANGEROUS TO LIFE AND HEALTH.

A city in California characterizes the effect of CO concentration this way:

Parts per Million	Responses
25	Permissible exposure level, no apparent toxic symptoms.
100	No poisoning for long period. Allowable for several hours.
200	Should not be exposed above this level for any period of time. A possible mild frontal headache in two to three hours.

Even though the generator normally produces very low levels of CO, an exhaust leak of untreated exhaust would be extremely dangerous. For this reason it is extremely important to install a CO detector near the generator and to be sure it is always turned on and functioning properly. If this detector sounds, do not turn it off, assuming it is a false signal. You can not taste, smell, or otherwise detect CO. Leave the detector on, turn off all engines and generators, evacuate the boat leaving ports and hatches open, and seek professional help.

As soon as CO leaves the exhaust outlet, the level is subject to dilution in the open air. The closer a person is to the exhaust outlet, the higher the concentration of CO.

In a closed space, such as the engine compartment, the boat, or underneath a stern swim platform, concentrations will potentially rise to the undiluted level emanating from the exhaust system due to a lack of fresh air to dilute the exhaust gas. Therefore, one should never rely on dilution of the exhaust to provide a margin of safety.

Westerbeke Low-CO generators achieve reduction of CO by precise control of the engine's air/fuel ration coupled with after treatment in a special catalyst. CO emissions are not the same for every model because each engine is different. Also, certain fuel system components are commonized across several engine models being adequate for some and extra-adequate for others, thus producing different CO levels for different models.

The fuel system which accomplishes the required precise air/fuel ratio control is comprised of many different components: purchased sub-assemblies, machined castings, sensors, electronics and others. Because of the extreme level of CO reduction, any variability in the functioning of any these components can and will cause variability of the CO output.

CO concentration also varies with load. Usually, but not always, the worst case CO concentration occurs at maximum load.

INSPECTION

The catalyst is critical to optimizing CO levels. Any water intrusion into the exhaust system will likely quickly compromise the proper operation of the catalyst.

Westerbeke's exhaust system installation instructions must be adhered to.

NOTE: *Water intrusion is not a product defect and is not covered under warranty, neither Westerbeke's normal product warranty nor the emissions specific warranty mandated by various regulating authorities such as EPA and CARB.*

Maintenance of any components affecting the flow of air or the flow of fuel to the engine is critically important, such as fuel filters and air filters (if any).

Inspection of the catalyst at the prescribed intervals is critically important. The exhaust elbow is removed by loosening the metal clamp to provide a view of the output surface of the catalyst. Any visual irregularity of the normal flush, honeycomb appearance is most likely a result of water intrusion. The cause of the irregularity must be identified and addressed. If there is irregularity, the catalyst and gasket must be replaced. Upon careful reassembly of the catalyst, exhaust elbow gasket, and exhaust elbow, check for the presence of CO while the engine is running. This must be performed with a CO analyzer.

CARBON MONOXIDE "CO"/ LOW-CO GENERATORS

IMPORTANT INFORMATION

Catalyst performance will degrade over time. As the generator accumulates operating hours, CO concentrations will increase. **The catalyst must be replaced every 2,000 hours of engine operation.**

Verification of satisfactory CO levels must be done seasonally or each 1,000 hours (which ever occurs first). Verification involves actual sampling of exhaust gas with an appropriate CO analyzer.

There are two locations where exhaust gas can be sampled. Dry, but hot, exhaust can be sampled at the plugged tapped hole in the exhaust elbow intended for back pressure measurements. Measurements at this location may not be practical in all instances due to the high exhaust temperature, temperature limits of the analyzer, safety concerns over temperatures involved or the possibility of high levels of CO. The other location is the boat's exhaust outlet, which contains entrained cooling water (except dry stack exhaust systems). Only analyzers with probes should be used at this location and it is critical that the probe not ingest water. Probe-type analyzers have an air pump drawing a gas sample through the probe. As a result, they tend to ingest water when it is present. Be sure to aim the probe downwards with the opening pointed in the direction of the water flow and just out of the flow. Position the analyzer as high as possible with the tubing leading to the probe running continuously downhill. Observe the usually translucent tubing between the probe and the analyzer and be sure no water is being ingested. If any water is ingested into the analyzer, it must be repaired or replaced and recalibrated.

When measuring CO at the exhaust outlet be aware of the ambient CO level by also measuring CO away from and upwind of the exhaust outlet, especially in marinas. the CO level at the exhaust will be influenced upwards by the ambient level.

Whenever taking the time to verify proper CO concentration from the exhaust with a CO analyzer, always take the opportunity to use the analyzer to "sniff" around the engine looking for CO from exhaust leaks. Pay close attention to the connection of the cylinder head to the exhaust manifold, the exhaust manifold to the water injected exhaust elbow, and all subsequent downstream exhaust components and hoses. Remember, exhaust gas that has not yet passed through the catalyst is raw, untreated exhaust and is very high in CO content.

Analyzers usually require periodic calibration. Follow the instructions that come with the analyzer very carefully regarding calibration.

The following are manufacturers that offer CO analyzers: Extech, TIF, Testo, TSI, Bacharach, Fluke, Monoxor, Fyrite, Zellweger Analytics, Industrial Scientific Corp, GFG, TPI, Teledyne and others. Westerbeke recommends analyzers with a probe connected to the analyzer by a length of transparent tubing. They are slightly more expensive than those with the sensor built into one end of the analyzer, but they allow you to sample the exhaust coming out of the boat's exhaust outlet.

EMISSIONS

This genset meets the requirements of California's Exhaust Emissions Standards as stated on the nameplate.

California users of this genset should be aware that unauthorized modifications or replacement of fuel, exhaust, air intake, or speed control system components that affect engine emissions are prohibited. Unauthorized modification, removal or replacement of the engine label is prohibited.

Federal Emissions Compliance Period: The Federal Emissions Compliance Period referred to on the nameplate indicates the number of operating hours for which the engine has been shown to meet Federal Emissions requirements.

Catagory C= 250 hrs, B=500 hrs, A =1000 hrs.

You should carefully review operator (Owner Installation and other manuals and information you receive with your genset. If you are unsure that the installation, use, maintenance or service of your genset is authorized, you should seek assistance from an approved WESTERBEKE dealer.

California genset users may use the table below as an aid in locating information related to the California Air Resources Board requirements for emissions control.

EMISSIONS CONTROL INFORMATION TABLE

Emissions Warranty Information	The California emissions control warranty statement is located in the same packet, if information as this manual when the genset is shipped from the factory.
Engine Fuel Requirements	The engine is certified to operate on unleaded gasoline. See <i>FUEL RECOMMENDATIONS</i> .
Engine Valve Adjustment	See <i>MAINTENANCE SCHEDULE</i> .
Engine Ignition Timing	See <i>MAINTENANCE SCHEDULE</i> .
Engine Lubricating Oil Requirements	See <i>ENGINE OIL RECOMMENDATIONS</i> .
Engine Adjustments	ECU.
Engine Emission Control System	The engine emission control system consists of engine design and precision manufacture.
Catalyst	See <i>MAINTENANCE SCHEDULE</i> .
Oxygen Sensor	See <i>MAINTENANCE SCHEDULE</i> .
Back Pressure	See <i>MAINTENANCE SCHEDULE</i> .

EXHAUST SYSTEM MAINTENANCE

DESCRIPTION

The catalyst is critical to minimizing exhaust emissions like CO. Any water intrusion into the engine's exhaust system will likely quickly compromise the proper operation of the catalyst.

Inspection of the catalyst at the prescribed intervals is critically important. The exhaust elbow is removed by loosening the metal clamp to provide a view of the output surface of the catalyst. Any visual irregularity of the normal flush, honeycomb appearance is most likely a result of water intrusion. The cause of the irregularity must be identified and addressed. If there is irregularity, the catalyst and sealing gasket must be replaced. The water injected exhaust elbow casting must be inspected also for corrosion and replaced as needed. Upon careful reassembly of the catalyst, new sealing gasket, and exhaust elbow, check for the presence of CO while the engine is running. This must be performed with a CO analyzer.

NOTE: For information on installing Exhaust Systems, refer to *WESTERBEKE'S INSTALLATION MANUAL* available at www.westerbeke.com.

Refer also to *TESTING THE BACK PRESURE* in this manual.

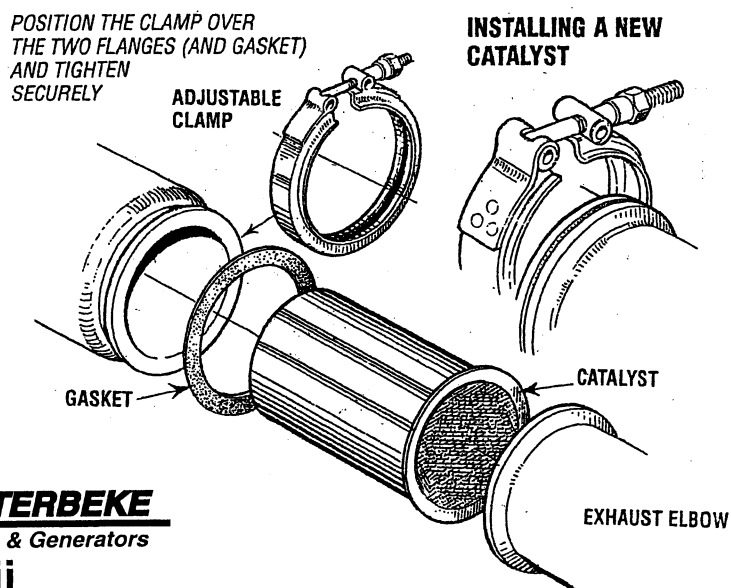

TABLE OF CONTENTS

CARBON MONOXIDE/LOW CO DATA.....	V	COMPONENT STATIC TESTING	53
EMISSIONS/EXHAUST CATALYST MAINTENANCE...VII		MAP SENSOR•STEPPER MOTOR.....	53
TESTING FOR ENGINE OVERHAUL	2	OIL PRESSURE SENSOR•OXYGEN SENSOR.....	54
TESTING ENGINE COMPRESSION.....	3	DC CIRCUIT BREAKER•WB OXYGEN SENSOR..	54
ENGINE TROUBLESHOOTING.....	4	HIGH/LOW RPM SHUTDOWN.....	54
DISASSEMBLY/ASSEMBLY PROCEDURES.....	6	EXHAUST TEMPERATURE SWITCH.....	54
REMOVING THE GENERATOR	8	MAGNETIC PICK-UP COIL	55
DISASSEMBLY OF EXTERIOR ENGINE COMPONENT	9	FUEL PRESSURE PUMP	55
REMOVING FUEL SYSTEM.....	10	FUEL INJECTOR	56
REMOVING THE TIMING BELT	11	AIR AND COOLANT TEMPERATURE SENSORS	56
		FUEL PRESSURE SYSTEM	56
DISASSEMBLY, INSPECTION AND REASSEMBLY		ENGINE TROUBLESHOOTING AND	
OF THE MAIN ENGINE.....	15-33	SOFTWARE DIAGNOSTICS.....	57
		CONTROL BOX COMPONENTS.....	57
COOLANT CIRCULATING PUMP	34	SOFTWARE DIAGNOSTICS (<i>CHART</i>)	58
EXHAUST MANIFOLD/HEAT EXCHANGER.....	35	ON-BOARD DIAGNOSTICS	62
DISTRIBUTER.....	36		
RAW WATER PUMP.....	37	BC GENERATOR	67
TIGHTENING TORQUES (<i>ENGINE</i>).....	35	AC TERMINAL CONNECTIONS.....	67
SPECIAL TOOLS (<i>ENGINE</i>).....	39	GENERATOR OUTPUT.....	68
		ROTATING AUXILLARY WINDING	68
SERVICE STANDARDS AND LIMITS	40	EXPLODED VIEW	69
		CONTROL BOX	69
ENGINE ADJUSTMENTS	42	BC GENERATOR TROUBLESHOOTING	70
SPEED SENSOR	42	EXCITING THE GENERATOR.....	70
IGNITION TIMING.....	42	MAIN STATOR RESIDUAL VOLTAGE	70
VALVE CLEARANCE	42	TESTING THE DIODES	71
CAM SENSOR.....	42	NO-LOAD VOLTAGE ADJUSTMENT	71
SPARK PLUGS.....	43	AC HERTZ CONVERSION	71
DRIVE BELTS	43	BC GENERATOR TROUBLESHOOTING (<i>CHART</i>)	72
IGNITION WIRES.....	43	INTERNAL WIRING SCHEMATIC.....	72
BLEEDING THE FUEL SYSTEM.....	44	TESTING THE EXCITER WINDINGS	73
OIL PRESSURE.....	45	TESTING CONTINUITY.....	74
MEASURING EXHAUST PRESSURE	45	TESTING CAPACITORS	74
IGNITION COIL-TESTING	46	BC ROTOR - TESTING	75
POINT GAP-TESTING	46	TESTING WINDINGS	75
IGNITER-TESTING	46	TESTING CONTINUITY.....	75
PICK-UP COIL-TESTING	46	SPECIAL TOOLS (GENERATOR)	76
BATTERY CHARGER-TESTING	47	SHORE POWER TRANSFER SWITCH	77
STARTER MOTOR	48		
EXPLODED VIEW.....	49	WIRING DIAGRAMS (#55536).....	78-82
SERVICING.....	50	DC AUXILLIARY POWER ADAPTER.....	83
ECU-ELECTRONIC CONTROL UNIT	52	REMOTE PANEL WIRING.....	83
SETTING/CHANGING ENGINE SPEED.....	52	REMOTE OIL FILTER	84
		ENGINE/GENERATOR SPECIFICATIONS	85
		HARDWARE TORQUES (<i>CHART</i>).....	86
		DECIMAL/METRIC CHART	87

TESTING FOR OVERHAUL

HOW TO DETERMINE ENGINE OVERHAUL PERIOD

Cause of Low Compression

Generally, the time at which an engine should be overhauled is determined by various conditions such as lowered engine power output, decreased compression pressure, and increased fuel and oil consumption. The lowered engine power output is not necessarily due to trouble with the engine itself, but is sometimes caused by improper oil, clogged filters or a faulty carburetor.

The decrease in compression pressure is caused by many factors. It is, therefore, necessary to determine a cause or causes on the basis of data produced by periodic inspection and maintenance. Oil analysis on a seasonal basis is a good means of monitoring engine internal wear. When caused by worn cylinders or piston rings, the following symptoms will occur:

- 1 Low engine power output
- 2 Increased fuel consumption
- 3 Increased oil consumption
- 4 Hard engine starting
- 5 Noisy engine operation

These symptoms often appear together. Symptoms 2 and 4 can result also from improper fuel regulation or a faulty carburetor. They are caused also by defective electrical devices such as the battery, starter or spark plugs. Therefore it is desirable to judge the optimum engine overhaul time by the lowered compression pressure caused by worn cylinders and pistons plus increased oil consumption. Satisfactory combustion is obtained only under sufficient compression pressure. If an engine lacks compression pressure, incomplete combustion of fuel will take place even if other parts of the engine are operating properly. To determine the period of engine overhaul, it is important to measure the engine compression pressure regularly. At the same time, the engine speed at which the measurement of compression pressure is made should be checked because the compression pressure varies with engine rpm. The engine rpm can be measured at the front end of the crankshaft.

NOTE: To test engine compression see the *ENGINE ADJUSTMENT* section of this manual.

OVERHAUL CONDITIONS

Compression pressure tends to increase a little in a new engine until piston rings and valve seats have been broken in. Thereafter, it decreases gradually with the progress of wear of these parts.

When decrease of compression pressure reaches the repair limit, the engine must be overhauled.

The engine requires overhaul when oil consumption is high, blowby evident, and compression values are at minimum or below. Refer to the following page for testing engine compression.

ENGINE OVERHAUL

The following sections contain detailed information relating to the major components and systems of the engine. Included are disassembly and inspection instructions for the guidance of suitable equipped and staffed marine engine service and rebuilding facilities. The necessary procedures should be undertaken only by such facilities.

Additional detailed information and specifications are provided in other sections of this manual, covering the generator, alternator, starter motor, engine adjustments, cooling pumps, etc.

DISASSEMBLY

1. Before disassembly and cleaning, carefully check for defects which cannot be found after disassembly and cleaning.
2. Clean the engine exterior.
3. Perform disassembly in a proper order using proper tools. Keep disassembled parts in order. Apply oil when necessary. Take special care to keep the fuel system parts from intrusion of dust and dirt.

SERIAL NUMBER LOCATION

Fill in the information below for reference.

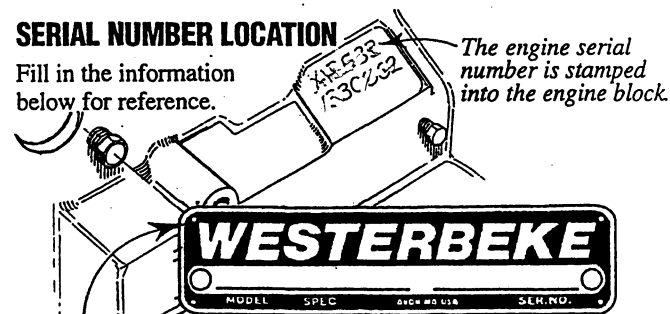

The engine model number and serial number are printed on a decal on the engine manifold.

The generator serial number is stamped on the top of the generator housing.

The generator specifications are printed on a decal on the side of the generator.

SPECIFICATION	50 HZ.	60 HZ.
MODEL		
RPM		
KW		
KVA		
VOLTS		
AMPS		
ENG. HP		
ENG. SER. NO.		
GEN. SER. NO.		
PF/PHASE		/
WIRES		
RATING		
INSUL. CLASS		
TEMP. RISE		
BATTERY		
C.I.D.		

PC INTERFACE SOFTWARE

Prior to overhaul, it is advised to operate the unit with PC Interface Software connected to the ECU. This will help determine system operation and whether system components may need replacement during overhaul.

TESTING THE ENGINE COMPRESSION

BY-PASSING THE ECU

DESCRIPTION

The ECU is by-passed by attaching an electrical jumper directly to the starter motor solenoid as illustrated below.

The electrical jumper can easily be assembled using a push button and connecting wires as shown.

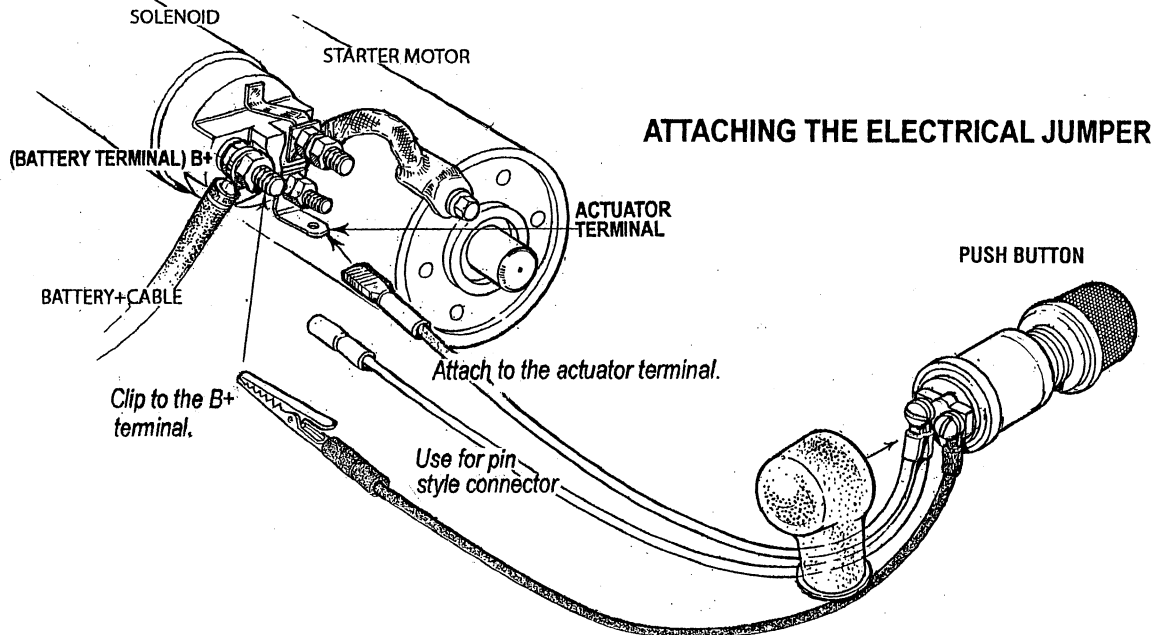

COMPRESSION TEST PROCEDURES

NOTE: The activation of the starter motor is a function of the ECU (Electronic Control Unit). To by-pass the ECU, a simple electrical jumper arrangement can be fabricated to connect between the battery B+ cable connection on the starter solenoid and the spade type activation connection on the starter solenoid with a push button in this jumper to make a circuit between these two connections and activate the starter solenoid.

1. Start the engine and allow it to warm up to its normal operating temperature. Then shut it down.
2. Open the DC breaker on the unit's control box to disable the ECU. Connect the jumper arrangement on the starter solenoid connections.
3. Close the unit's raw water thru-hull opening. This is to prevent the raw water pump from pumping water into the unit's exhaust system during the test as no or very little exhaust pressure will be present during the test to help expel water from the unit's exhaust system during engine cranking.
4. Remove the high tension leads from the spark plugs and remove all spark plugs.
5. Thread the compression gauge adapter into the spark plug opening of cylinder #1. Connect the compression gauge to the adapter.
6. Activate the starter motor using the push button on the electrical jumper arrangement for the starter. Allow the engine to crank, observing the compression gauge. Allow the engine to crank until the gauge reaches a maximum reading where further cranking does not produce a higher reading on the compression gauge. Stop cranking and record the pressure.
7. Remove the compression gauge and adapter from the #1 spark plug opening and install it in the #2 cylinder spark plug opening and repeat step -6.
8. Proceed to the next cylinder and repeat step #6 until all cylinders have been tested and there pressures recorded.

STANDARD COMPRESSION PRESSURE AT 400 RPM
178 PSI (12.5 KG/CM²)
LOWER LIMIT - 137 PSI (9.6 KG/CM²)

NOTE: A wet test can be performed on cylinders with low compression figures. This will help determine if the low compression is the result of worn cylinders/rings or worn valve seats/valves or both. Place a few squirts of oil into the cylinder and the perform the compression test on that cylinder.

- a. A dramatic rise in recorded compression value would indicate worn cylinder/rings.
- b. A minimal rise in recorded compression value would indicate both cylinder/ring and valve wear.
- c. No appreciable rise in recorded compression would indicate valve/valve seat wear.

ENGINE TROUBLESHOOTING

The following troubleshooting chart describes certain problems and causes relating to engine service. Also note there is a Diagnostic Troubleshooting section.

Note: When servicing the engine/generator, the main circuit breaker (control panel) disconnects all AC power and can be switched off and reset manually.

Problem	Possible Cause
Engine does not crank.	<ol style="list-style-type: none"> 1. DC panel breaker OFF. 2. DC battery OFF. 3. K2 relay faulty. 4. Starter solenoid faulty. 5. DC battery low/dead OR LOOSE BATTERY CABLE. 6. Wiring harness disconnected 7. Water filled cylinder. 8. DC panel 8 amp buss fuse is faulty.
Engine cranks, does not start (engine will crank 8 seconds) (3 crank cycles before underspeed fault occurs)	<ol style="list-style-type: none"> 1. Fuel starvation. 2. Air in fuel system. 3. Fouled spark plugs. 4. Faulty ignition coil. 5. Stuck throttle body.
Engine starts, runs and the shuts down.	<ol style="list-style-type: none"> 1. Fuel starvation. 2. Air in fuel system. 3. Faulty shutdown switch/sensor. 4. Faulty fuel pump.
Engine hunts.	<ol style="list-style-type: none"> 1. Air in fuel system. 2. Faulty fuel pump. 3. Low octane fuel (lower than 89). 4. Faulty speed sensor (crankshaft).
Engine misfires/back firing.	<ol style="list-style-type: none"> 1. Low octane fuel (lower than 89). 2. Dirty air intake screen. 3. High tension ignition wires. 4. Exhaust restriction. 5. Worn/fouled spark plug. 6. Faulty ignition coil. 7. Low or no fuel pressure. Poor quality fuel.
Engine overheats/engine temp LED is illuminated.	<ol style="list-style-type: none"> 1. Raw water coolant flow obstruction. 2. Coolant level low. 3. Faulty impeller. 4. Pump belt loose/broken. 5. Stuck thermostat. 6. Air in cooling system (fresh water).
Exhaust temp LED is illuminated.	<ol style="list-style-type: none"> 1. Loss of coolant flow/faulty pump. 2. Faulty exhaust temperature switch. 3. Faulty fire shutdown
Low oil pressure/oil pressure LED is illuminated.	<ol style="list-style-type: none"> 1. Oil level low. 2. Faulty oil pressure sensor. 3. Oil viscosity incorrect.

ENGINE TROUBLESHOOTING

Problem	Possible Cause
No DC charge to starting battery.	<ol style="list-style-type: none"> 1.Circuit fuse faulty/blown (two fuses). 2.Faulty circuit connection. 3.Faulty regulator/battery charger. 4.Bridge rectifier. 5.Charge AC winding.
High DC Charge to battery.	<ol style="list-style-type: none"> 1.Battery charger misadjusted. 2.Faulty starter solenoid.
Starter stays energized after start.	<ol style="list-style-type: none"> 1.Faulty K1 relay. 2.Faulty starter solenoid.
Poor performance at generator speed.	<ol style="list-style-type: none"> 1.Low octane fuel. 2.Incorrect ignition timing. 3.Fuel supply issue. 4.High engine compartment temperature (122° F max).
Black exhaust smoke.	<ol style="list-style-type: none"> 1.Dirty air screen. 2.Faulty injector.
Blue exhaust smoke.	<ol style="list-style-type: none"> 1.Lube oil is diluted. 2.Crankcase breather tube is clogged. 3.High lube oil level.
White exhaust smoke. (Check engine fault)	<ol style="list-style-type: none"> 1.Faulty oxygen sensor.. 2.Poor connection at sensor.
Check engine LED's are illuminated.	<ol style="list-style-type: none"> 1.Diagnostic software required.
Speed LED's are illuminated-no flashing.	<ol style="list-style-type: none"> 1.Throttle shaft sticking. 2.Intake manifold vacuum leak.
Pair of Speed LED's are illuminated-flashing.	<ol style="list-style-type: none"> 1.AC generator overload. 2.Fuel starvation.
External alarm LED is illuminated.	<ol style="list-style-type: none"> 1.Loose connection. 2.Faulty fire suppression shutdown devise. 3.Incorrect setting on shutdown device (contacts should n/c)

DISASSEMBLY PROCEDURES

PREPARATION FOR DISASSEMBLY

- Clean or wash the engine exterior.
- Do not remove or disassemble the parts that require no disassembly.
- When disconnecting sensor wires, label and tape the ends.
- Perform disassembly in a proper order using proper tools. Keep disassembled parts in order. Apply oil when necessary. Take special care to keep the fuel system parts from intrusion of dust and dirt.
- Parts must be restored to their respective components from which they were removed at disassembly. This means that all parts must be set aside separately in groups, each marked for its component, so that the same combination or set can be reproduced at assembly.
- Pay attention to marks on assemblies, components and parts for their positions or directions. Put on marks, if necessary, to aid assembly.
- Carefully check each part or component for any sign of faulty condition during removal or cleaning. The part will tell you how it acted or what was abnormal about it more accurately during removal and cleaning.

REMOVE EXTERIOR COMPONENTS

With the generator separated from the engine, begin the following step by step procedure to disassemble the exterior parts.

NOTE: *Mount the engine securely on a suitable engine stand.*

1. **Remove the start motor and drive belt.**
Label the wires and cables.
2. **With the hoses disconnected, remove the thermostat housing and housing gasket, leaving the temperature sender in place.**
3. **Remove the magnetic pick-up from the bell housing.**
4. **Remove the bell housing and the circuit breaker/ pre-heat solenoid mounting bracket**
Remove the engine back plate.
5. **Remove the oil filter, oil cooler, oil hoses and mounting bracket.** Make note of the hose arrangements.
6. **Remove the engine mounted raw water pump, complete with its adapter mounting plate.** See *RAW WATER PUMP* for parts breakdown.
8. **Remove the engine heat exchanger and exhaust elbow.** Refer to *HEAT EXCHANGER EXHAUST MANIFOLD* in this manual.
9. **Remove the fresh water cooling pump.** Refer to *COOLANT CIRCULATING PUMP* in this manual.

ENGINE ASSEMBLY

GENERAL INFORMATION

- Be careful not to mix bolts and nuts. Metric and S.A.E. bolts are used on various engine assemblies.
- During assembly, recheck clearances and insure that parts are being assembled in their proper order and facing in the correct direction in relation to the engine block, such as, pistons, piston rings, bearings and bearing caps.
- Apply lubricating oil to moving parts during assembly. Insure that moving parts, when assembled on the engine, rotate or slide and are not subject to binding or excessive tension.
- If there are mating marks scribed during disassembly, reference them correctly for assembly.
- Use new gaskets, lockwashers, O-rings, packings and seals.
- Tighten the bolts and nuts on important parts of the engine to specified torques using a reliable torque wrench.
- When required, use liquid sealants when required on nuts, bolts and gaskets. Refrain from using tape sealants.
- Most gaskets and many bolt washers are asymmetrical, make certain they are positioned properly.

Torquing Hardware

Prevent mechanical damage by running fasteners down in three steps-1/2, 2/3, and 1/1 torque. Exceptions are torque-to-yield bolts and rocker arm shaft fasteners. The former are torqued as indicated. The latter-rocker shaft fasteners-should be brought down in very small increments, working from the center bolts out. Gaskets, especially head gaskets, might be damaged during assembly, they should be positioned with great care. See *TORQUE SPECIFICATIONS* thru out this manual.

Sealants and Lubricants

Oil based PERMATEX #2 and its HIGH TACK equivalent are excellent all purpose sealers. They are effective in just about any joint in contact with coolant, raw water, oil, or fuel. A light coating of oil or LIQUID TEFLON can be used on rubber gaskets and o-rings.

LOCTITE hydraulic red sealant should be used on oil adapter hoses and the oil filter assembly.

Coat both surfaces of the oil pan gasket with high temp RED SILICONE SEALER.

When installing gaskets that seal around water (coolant) passages, coat both sides with WHITE SILICONE GREASE.

Do not use sealant when installing a new gasket.

HIGH-COPPER ADHESIVE SPRAYS are useful for holding a gasket in position during assembly.

Specialized gasket sealers such as HYLOMAR work well in applications requiring non-hardening properties. HYLOMAR is particularly effective on copper cylinder-head gaskets and resists fuel, oil , and water.

NOTE: *TAPE SEALANTS should be used on pipe plugs and fitting that connect water coolant passages.*

Bolts and Fasteners

Lightly oil head bolts and other fasteners as you assemble them. Bolts and other plugs that penetrate the water jacket should be sealed with PERMATEX #2 or HIGH TACK.

When assembling the flywheel, coat the bolt threads with LOCTITE blue.

LITHIUM based grease is waterproof, ideal for water pump bearings and stuffing boxes.

Antiseize compounds and thread locking adhesives such as LOCTITE protect threaded components yet allow them to come apart when necessary. LOCKTITE offers levels of locking according to the job.

Heavily oil all sliding and reciprocating components, always use clean engine oil.

GENERATOR / ENGINE DISASSEMBLY

DESCRIPTION

The MCG generator models are not bulky or extremely heavy (330-370 lbs. With reasonable effort, it can be removed from its location in the vessel.

Turn OFF the DC battery power for the generator. Disconnect the DC battery cables. Disconnect the AC output connection from the generator's AC breaker. Unplug any remote Start/Stop panel connection.

Close OFF the raw water sea-cock and disconnect the raw water supply at the raw water pump. Separate the exhaust at the water injected exhaust elbow. Shut OFF the fuel supply and disconnect the supply at the inlet connection at the engine. Be conscious of fuel spillage.

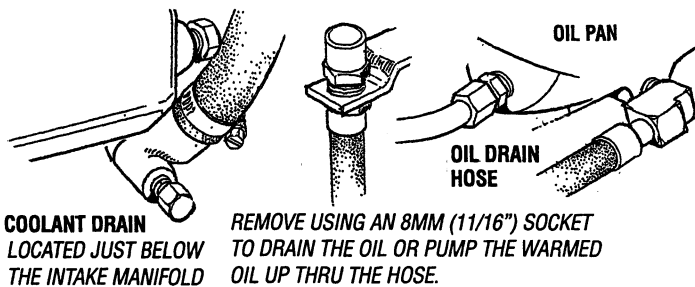

Unfasten the generator from its mounting rails or the mounting rails from the platform and remove the generator from the boat.

Once the generator is securely mounted on the work bench, drain the engine oil and coolant.

Disconnect and remove the control panel with wiring harness. Label all connections so they can be properly reconnected. Take digital photos if needed.

SEPERATING THE GENERATOR FROM THE ENGINE

1. Remove the Louvered Cover.
2. Remove the nuts/washers from the three Securing Studs. (On some units, the hex nut is part of the stud).
3. Carefully work the Bearing Support Housing off the Rotor Carrier Bearing.
4. Slide the Generators Housing away from the Adapter Plate and Rotor.
5. Unbolt the Rotor Assembly from the Flywheel.
6. Unbolt the Adapter Plate from the Back Plate.
7. Unbolt the Flywheel.

Set all generator components aside for cleaning, inspection, testing and painting as may be needed and cover!

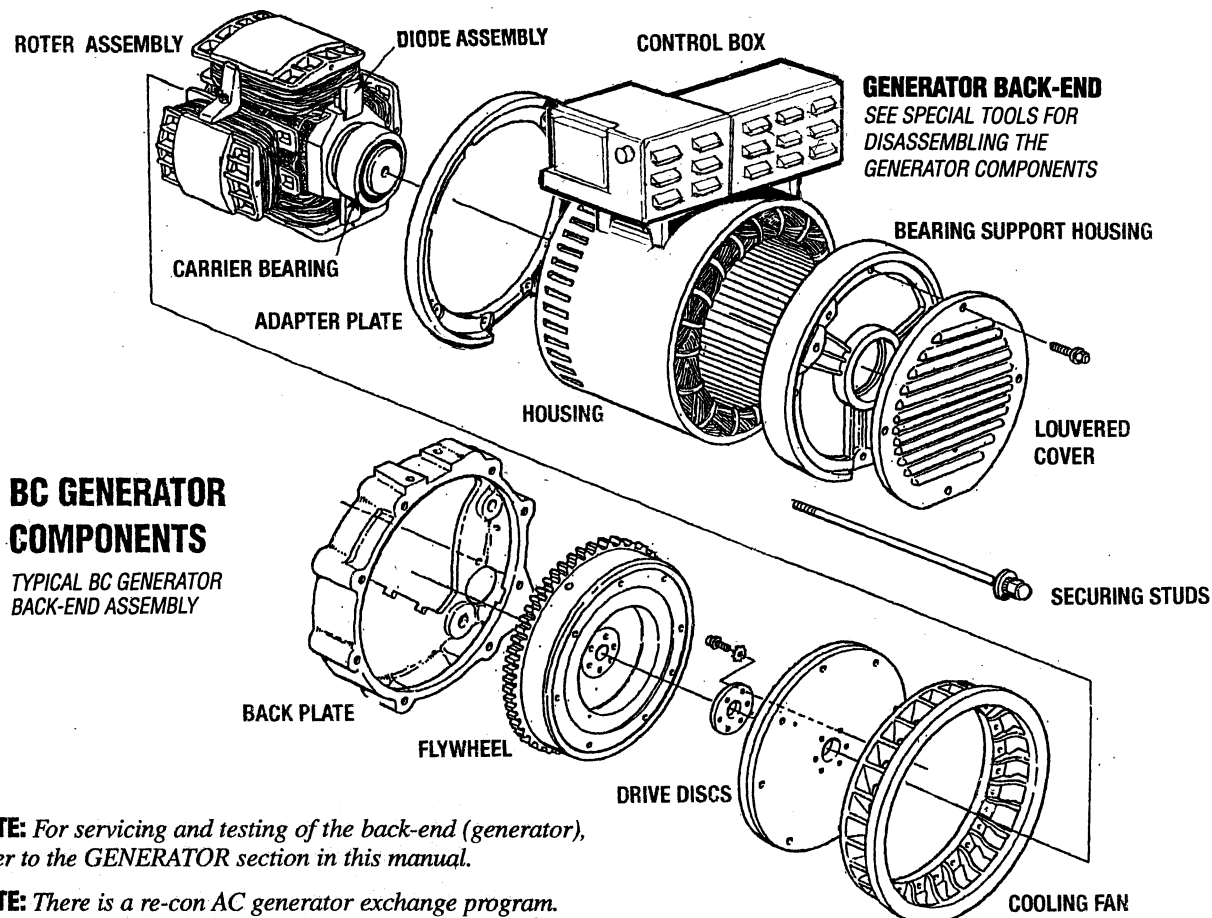

BC GENERATOR COMPONENTS

TYPICAL BC GENERATOR
BACK-END ASSEMBLY

NOTE: For servicing and testing of the back-end (generator), refer to the GENERATOR section in this manual.

NOTE: There is a re-con AC generator exchange program. Contact your WESTERBEKE Dealer.

ENGINE DISASSEMBLY

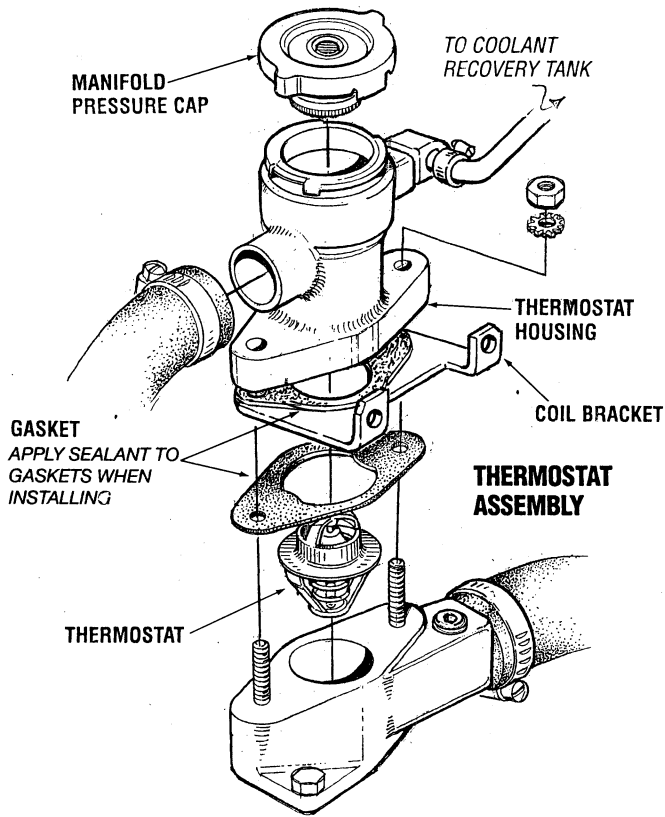

THERMOSTAT

Remove the thermostat assembly and clean the interior chambers. Inspect the seals in the pressure cap when reassembling. Replace the thermostat and gasket.

RAW WATER PUMP

Loosen the raw water pump, remove the drive belt and then remove the raw water pump. Refer to the Table of Contents for the exploded Parts Drawing.

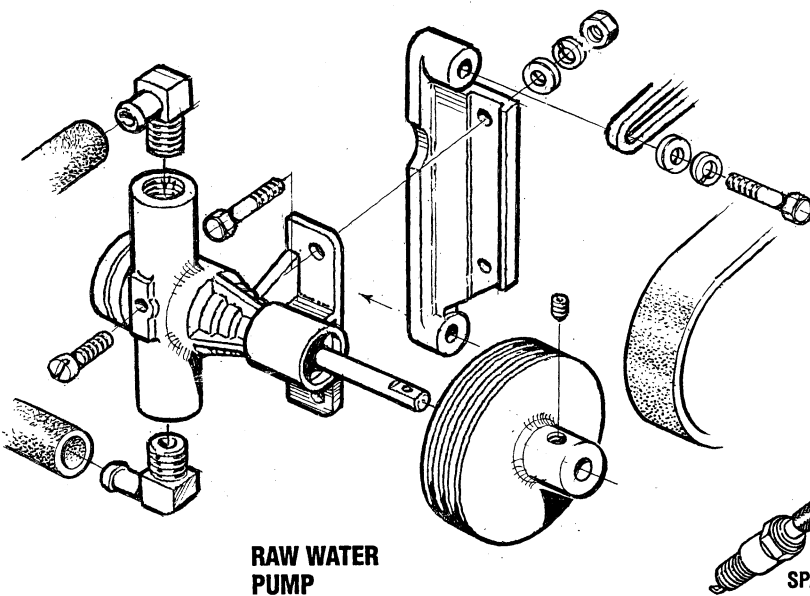

OIL FILTER ASSEMBLY

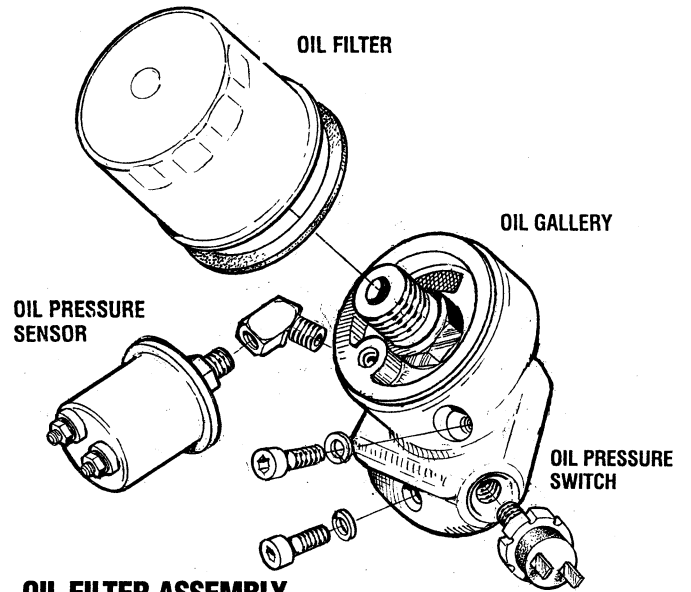

OIL FILTER ASSEMBLY

Remove and properly dispose of the oil filter. Disassemble the oil gallery casting from the engine being careful to clean up any spilled oil. Clean the interior passage in the casting, cover and set aside.

EXHAUST ELBOW

NOTE: Refer to the Table of Contents for the disassembly and servicing of the engine's Coolant Circulating Pump and the removal of the Exhaust Manifold and Elbow Casting.

DISTRIBUTOR

Detach and remove the ignition wires, the distributor and spark plugs. Refer to *DISTRIBUTOR DISASSEMBLY* in the manual. See *ENGINE ADJUSTMENTS* for information on ignition wires and spark plugs.

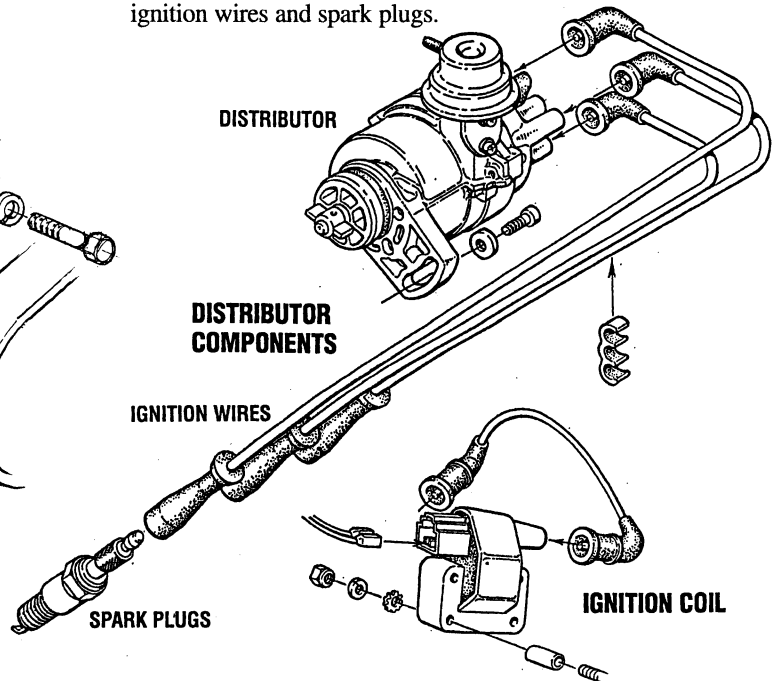

DISASSEMBLY OF FUEL SYSTEM COMPONENTS

REMOVING ASSEMBLIES

The fuel system components can be removed as assemblies by simply unbolting their brackets from the engine. Unplug the fuel injectors and wiring harness connections and disconnect the fuel lines and coolant hoses.

Mark and label the connections for re-assembly.

NOTE: Coolant hoses and fuel lines may need to be drained off as they are disconnected.

CAUTION: Clean up spilled fuel immediately and dispose of rags properly.

Remove all the bolts and nuts that fasten the brackets to the engine. The components can then be removed as complete assemblies, covered over and set aside. This allows full access to the engine block.

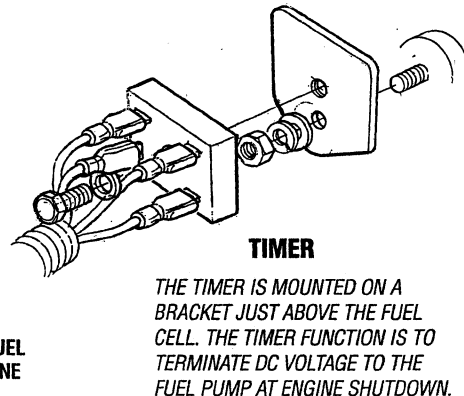
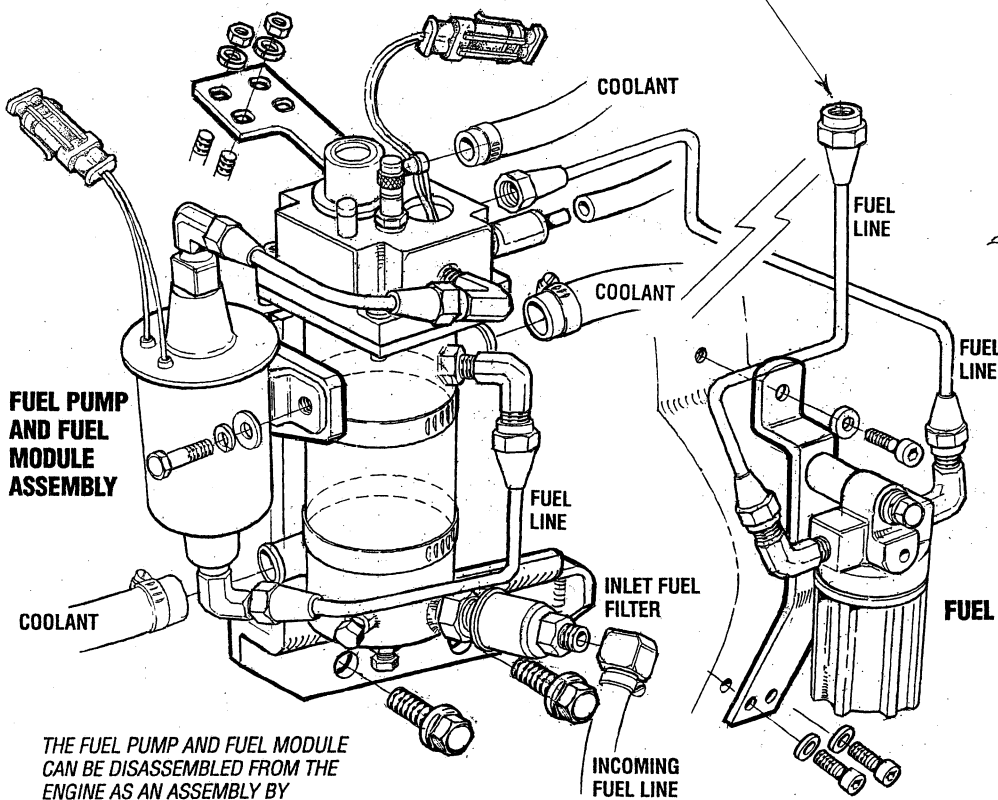
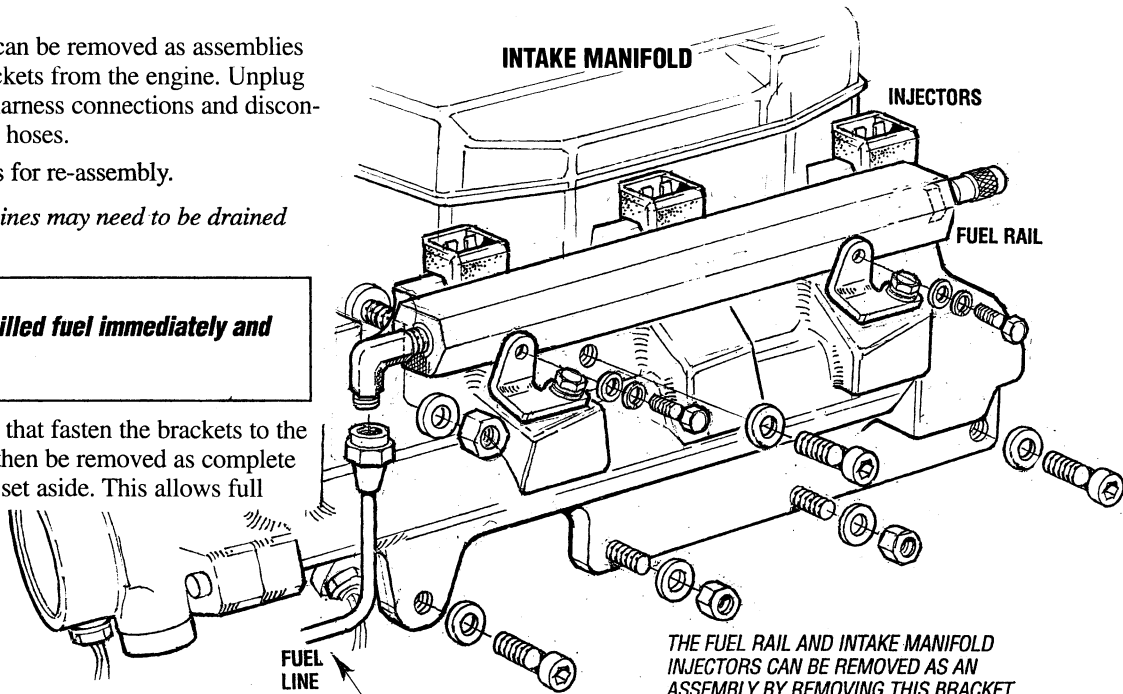

FUEL SYSTEM COMPONENTS

Incoming fuel (from the owner installed Gasoline Water Separator/Filter) is pumped thru the Inlet Fuel Filter into the Fuel Module by the Electric Fuel Pump. The fuel is cooled as it circulates thru the Fuel Module and then is pumped by the Electric Fuel Pump to the High Pressure Pump Module and to the Secondary Fuel Filter. The fuel passes to the Fuel Rail and is delivered (under pressure) to the Fuel Injectors.

TIMING BELT DISASSEMBLY

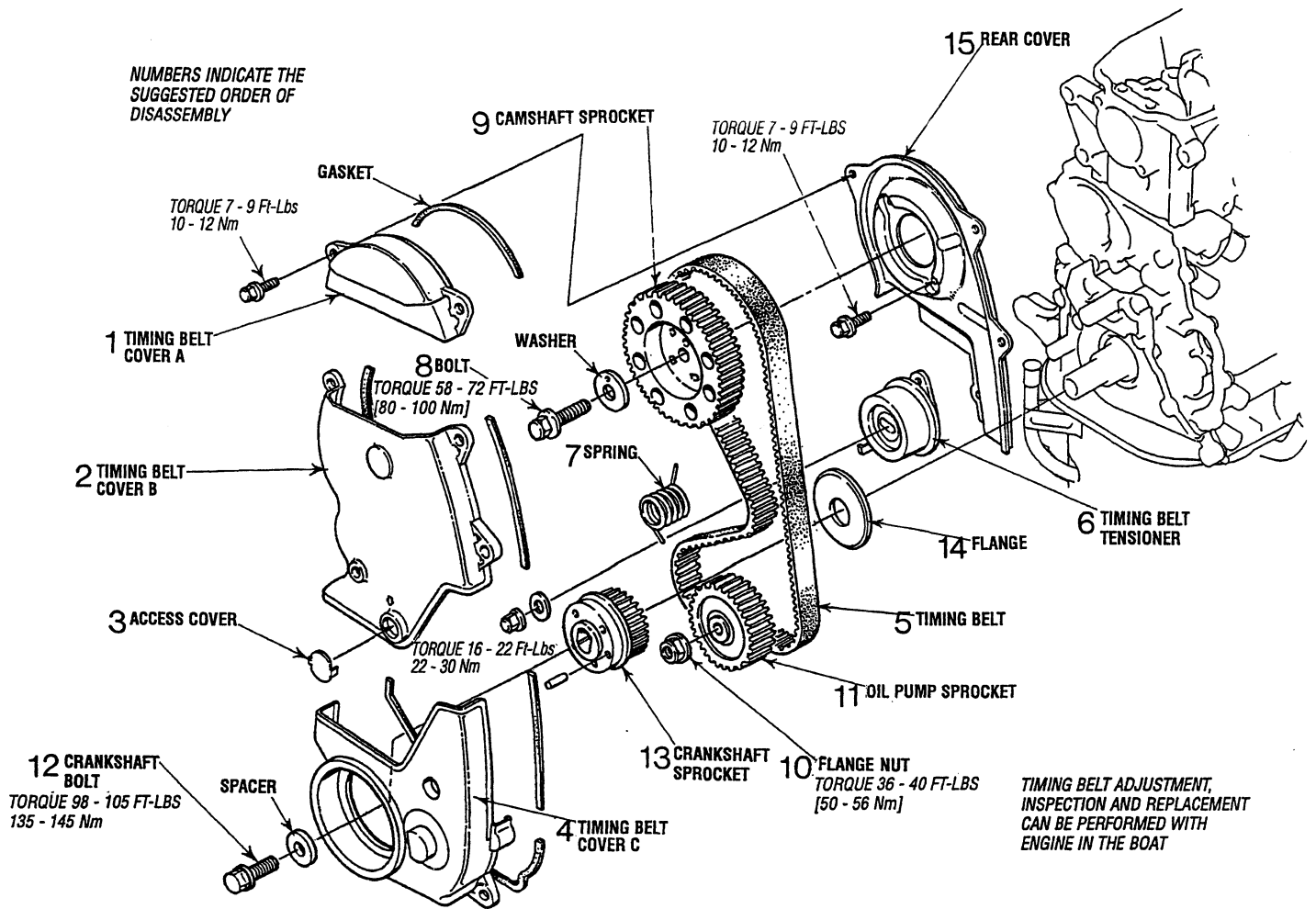

INSTRUCTIONS FOR INSPECTING AND REPLACING THE TIMING BELT

WESTERBEKE requires as normal maintenance, replacing the timing belt after 1000 engine operating hours. The timing belt should always be replaced during an engine overhaul.

The adjustments, inspection, and replacement procedures may be performed without removing the generator from the boat. THE TIMING BELT PART NUMBER IS #043036

Timing Belt Removal

1. Turn the crankshaft clockwise to align the timing mark on the camshaft sprocket and timing belt rear cover.

NOTE: Always turn the crankshaft clockwise.

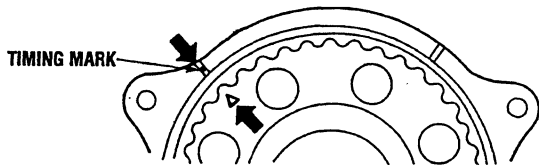

2. Remove the plug on the left surface of the cylinder block and insert a rod with a diameter of 0.31 in (8 mm) to lock the counterbalance shaft.

NOTE: Be sure to use an inserting rod with a diameter of 0.31 in (8 mm).

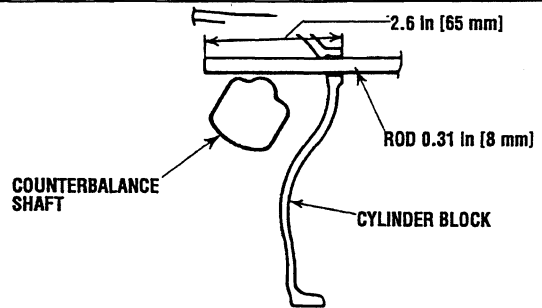

3. Loosen the timing belt tensioner nut.
4. Move the timing belt tensioner toward the water pump, and temporarily tighten the nut to hold the tensioner in that position.

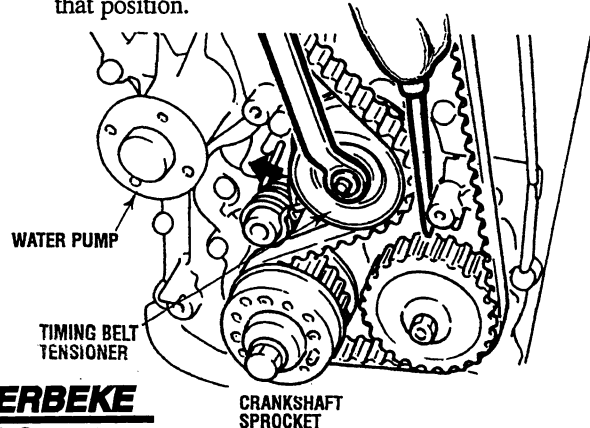

TIMING BELT DISASSEMBLY

- Remove the timing belt.

NOTE: If the timing belt is to be reused, draw an arrow on the belt to indicate the direction of rotation (clockwise).

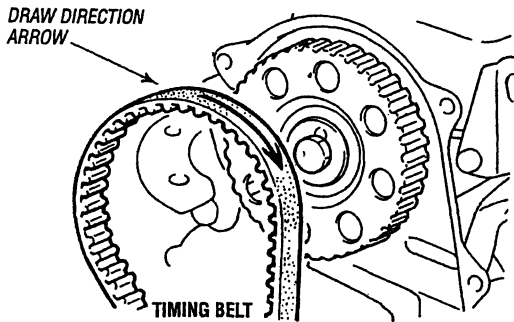

Camshaft Sprocket Removal

- Remove the camshaft sprocket bolt without turning the camshaft.

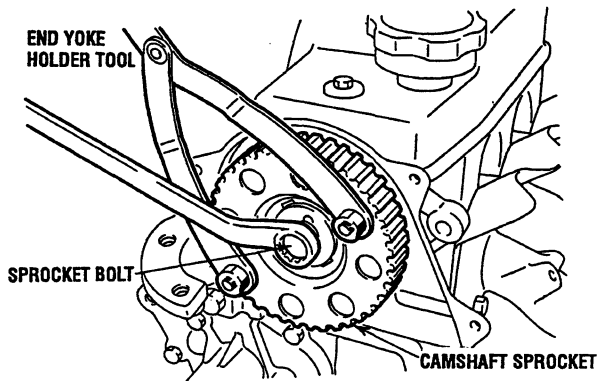

Oil Pump Sprocket Flange Nut Removal

- Remove the plug from the left side of the cylinder block.
- Insert an 0.31 in (8 mm) diameter round bar to lock the counterbalance shaft.
- Remove the oil pump sprocket flange nut.

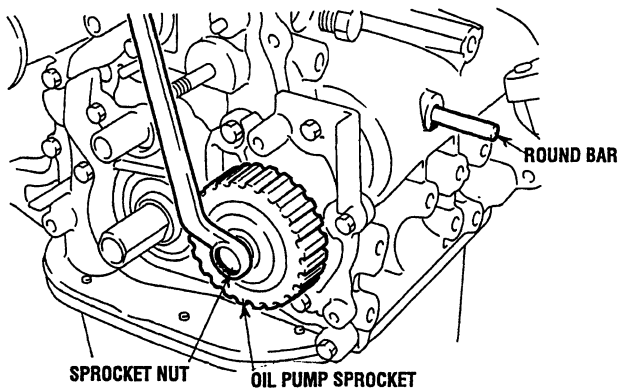

Crankshaft Bolt Removal

- Lock the crankshaft in position.

NOTE: Do not turn the crankshaft.

- Remove the crankshaft bolt.

Timing Belt Inspection

Replace the belt if any of the following conditions exist:

- Hardening of the back rubber, leaves no indent when pressed with fingernail (back side is glossy).
- Cracks on rubber back.
- Cracks or peeling of canvas.
- Cracks on tooth bottom.
- Cracks on belt.
- Abnormal wear of belt sides. The sides are normal if they are sharp as if cut by a knife.
- Abnormal wear on teeth.
- Tooth missing and canvas fiber exposed.

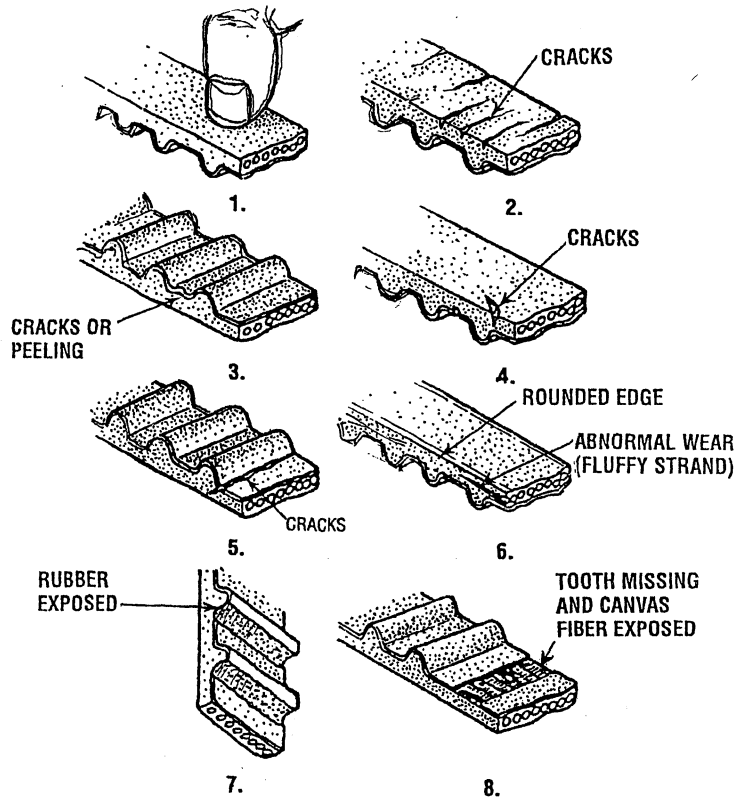

Tensioner Inspection

- Replace the tensioner if the pulley binds, rattles or is noisy when turned.

ENGINE TIMING BELT

Flange Installation

1. Mount the flange so that its side shown by the heavy arrow in the illustration faces toward the sprocket.

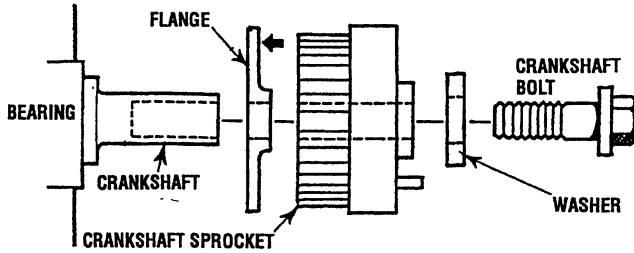

Crankshaft Bolt Installation

1. Lock the crankshaft.
NOTE: Do not turn the crankshaft.
2. Tighten the crankshaft bolt to the specified torque.

Oil Pump Sprocket Flange Nut Installation

1. Insert the round bar into the plug hole in the left side of the cylinder block to keep the counterbalance shaft from turning.
2. Install the oil pump sprocket.
3. Tighten the nut to the specified torque.

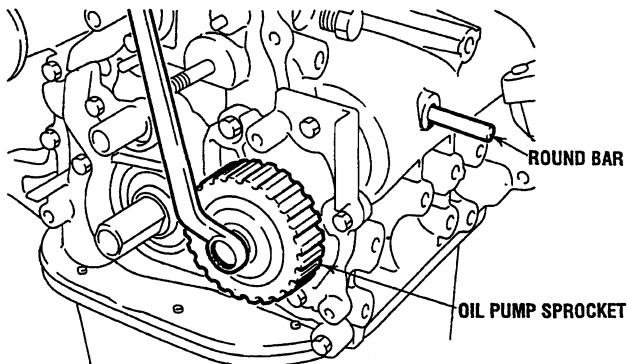

Camshaft Sprocket Bolt Installation

1. Tighten the bolt to the specified torque.
CAMSHAFT BOLT TORQUE 58 - 72 Ft-lbs (80 - 100 Nm)

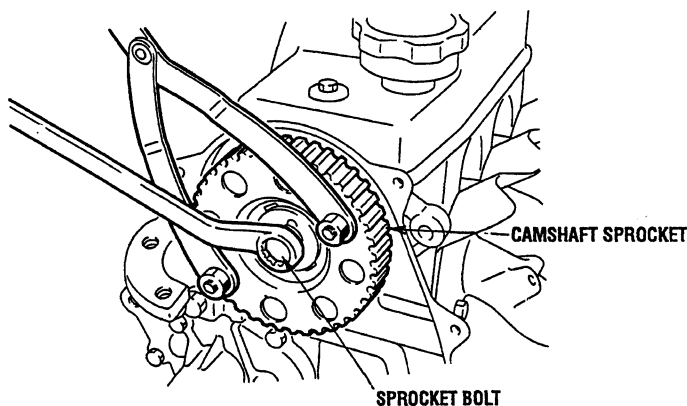

Tensioner Spring/Timing Tensioner Installation

1. Install the tensioner spring and timing belt tensioner.
2. Hook the tensioner spring onto the bend of the timing belt tensioner bracket and the stopper pin on the cylinder block.
3. Move the timing belt tensioner as close as possible to the water pump; temporarily tighten the tensioner nut.

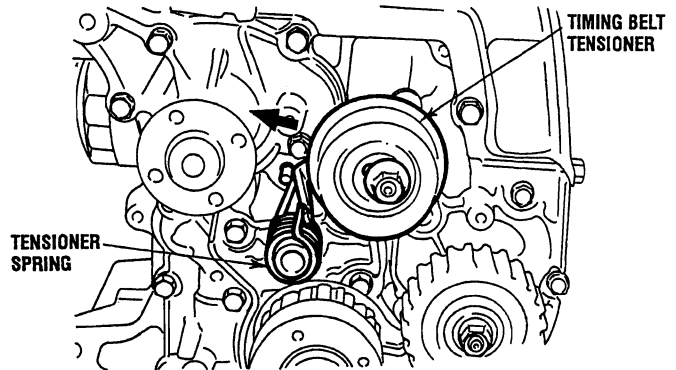

Timing Belt Installation

1. Align the triangular marking on the camshaft sprocket with a marking on the timing belt rear cover.
2. Align the notch in the crankshaft sprocket flange with the marking on the front case.
3. Align the triangular marking on the oil pump sprocket with the marking on the front case, and then insert a 2.56 in. (65 mm.) or longer, 0.31 in. (8mm.) diameter round bar into the plug hole in the left side of the cylinder block.

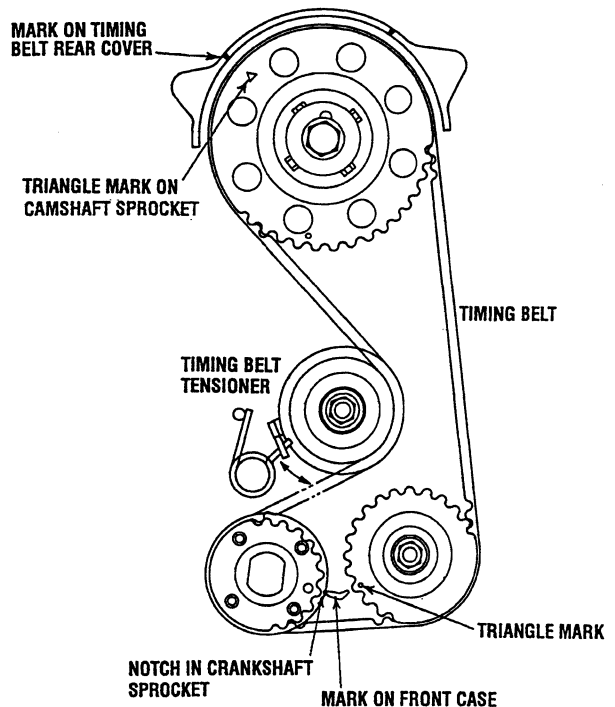

ENGINE TIMING BELT

At this time, check that the moveable range of teeth on the oil pump sprocket is according to specifications.

STANDARD VALUE: 4 to 5 teeth in forward direction.
1 to 2 teeth in reverse direction.

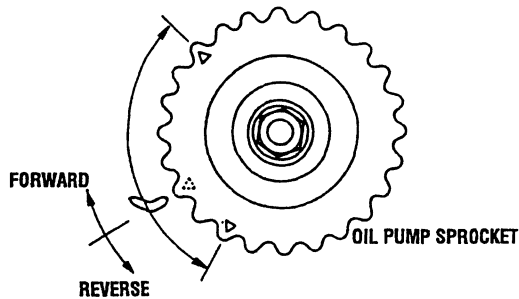

4. If the movable range of the teeth on the oil pump sprocket exceeds the specified range, correct as follows:
 - a. Pull out the round bar from the plug hole in the left side of the cylinder block.
 - b. Turn the oil pump sprocket one turn at a time until the round bar can again be inserted.
 - c. Check that the movable range of the oil pump sprocket is in the specified value.
5. Set the timing belt over the crankshaft sprocket and then over the oil pump sprocket and camshaft sprocket, in that order.

NOTE: Ensure that the tension side of the timing belt is not slack. Keep the round bar inserted until the timing belt has been placed. After this step, be sure to remove the round bar.

6. Apply counterclockwise force to the camshaft sprocket to make the belt taut on the tension side, and make sure that all timing marks are lined up.

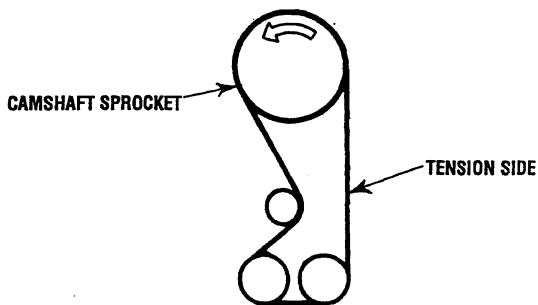

7. Loosen the temporarily tightened tensioner nut on the water pump side 1 or 2 turns, and tension the belt making use of the spring force.

8. Turn the crankshaft *clockwise* by nine camshaft sprocket teeth (81°) to align the timing mark on the camshaft sprocket with the tensioner set mark on the timing belt rear cover.

CAUTION: This operation is performed to give a proper tension to the timing belt, so do not turn the crankshaft counterclockwise and push the belt to check the tension.

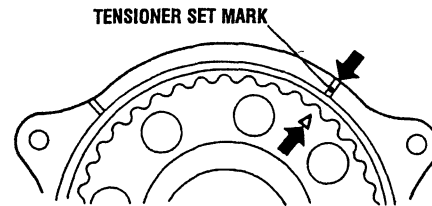

9. Make sure that the timing belt teeth are engaged with the camshaft sprocket teeth along the portion of the sprocket shown by the curved arrow in the illustration below. Then tighten the tensioner nut.
10. Pull the timing belt in the center of the tension side toward the sealing gasket line for the belt cover, as illustrated. Make sure that the clearance between the back of the belt and the sealing line is the standard value.

STANDARD VALUE: 0.47in. (12mm)

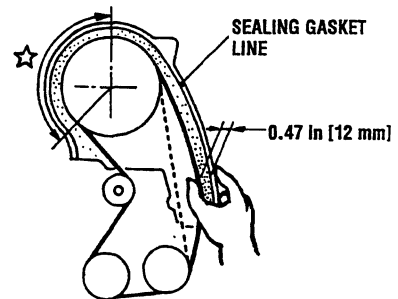

11. Pull out the rod from the plug hole on the left surface of the cylinder block and apply the specified sealant. Then tighten the plug to the specified torque.

Specified sealant value: 3M ATD Part No. 8660 or equivalent.

TIGHTENING TORQUE: 11-16 ft.lbs. (15-22 Nm)

CYLINDER HEAD AND VALVES

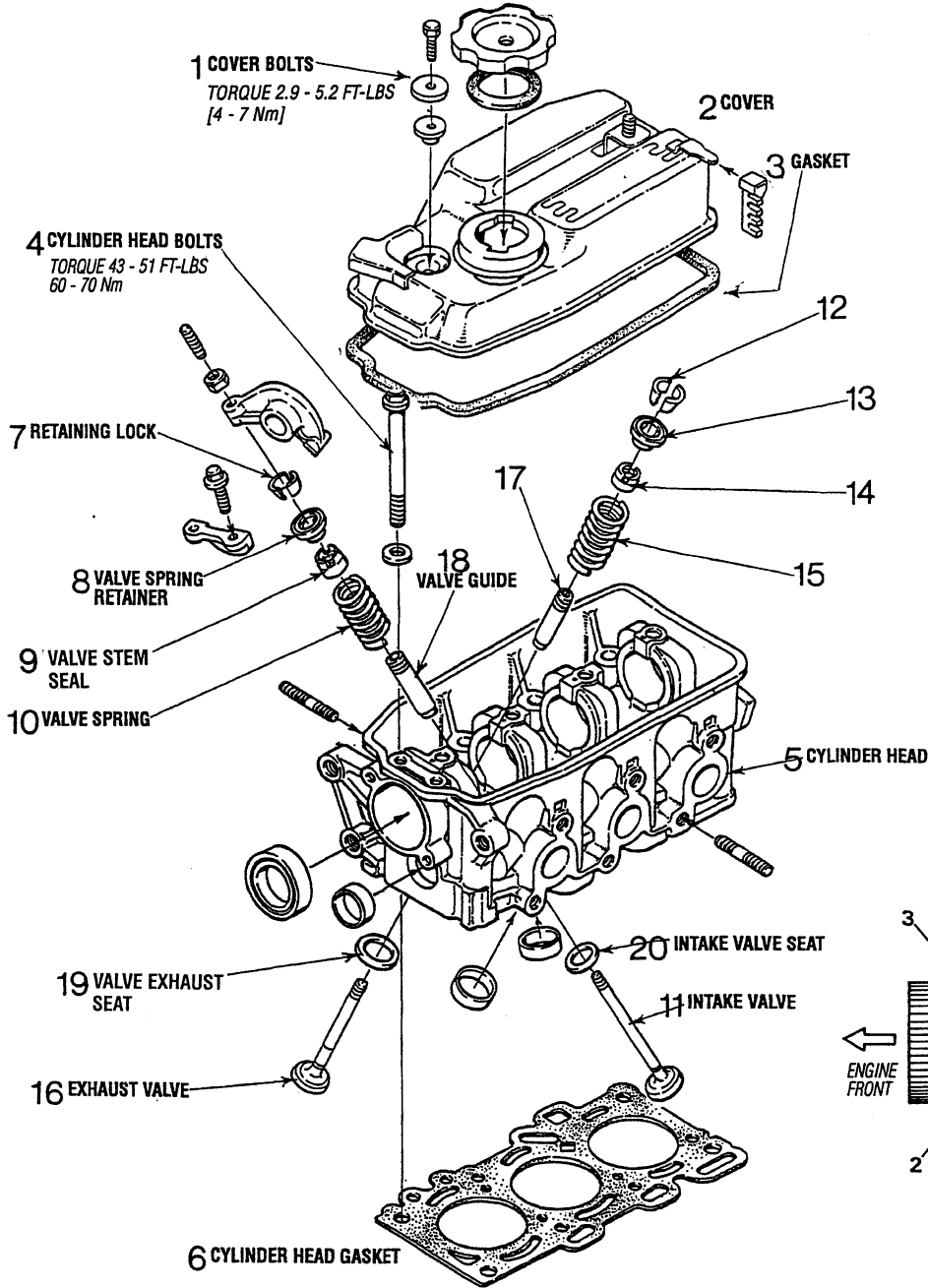

NUMBERS INDICATE THE SUGGESTED ORDER OF DISASSEMBLY

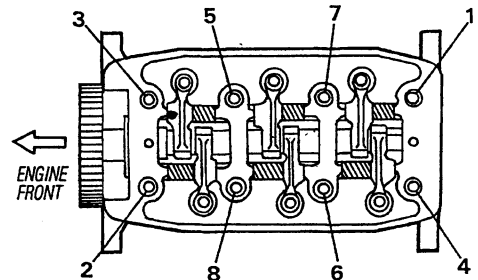

CYLINDER HEAD BOLTS LOOSENING SEQUENCE

REMOVING THE CYLINDER HEAD FROM THE CYLINDER BLOCK

Disassemble the cover bolts as shown above, taking care not to lose the washer and insert. Remove the rocker cover and rocker cover gasket.

Loosen each of the cylinder head bolts, a little at a time so as to avoid the possibility of distorting the cylinder. Repeat several times until the bolts are unfastened. Follow the sequence shown in the diagram.

Remove the cylinder head and the cylinder head gasket.

Remove the valve retainers, valve springs and valves from the cylinder head. When removing each valve retainer, depressing the retainer against the valve spring and remove the retainer lock. Identify each valve by putting a mark indicating the number of the cylinder from which the valve was removed.

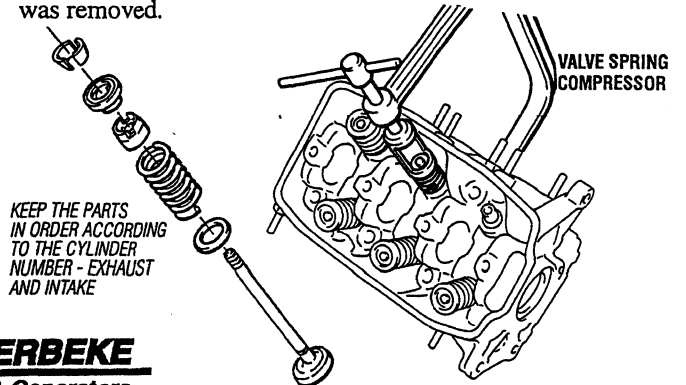

CYLINDER HEAD AND VALVES

Use pliers to remove the valve stem seals. Do not reuse the stem seals.

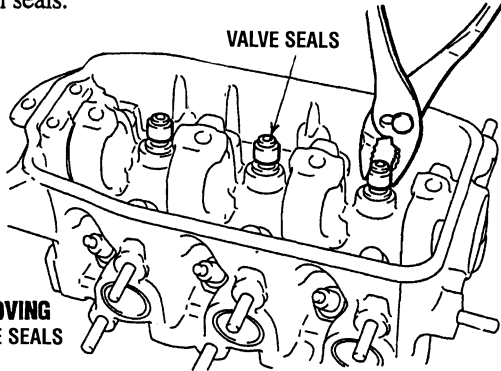

REMOVING VALVE SEALS

CYLINDER HEAD INSPECTION

Before cleaning check the cylinder head for water leaks, cracks and other possible damage.

Clean by completely removing the oil, scaling, carbon and sealant. After flushing the oil passage, blow air thru to ensure that no portion of the oil passage is clogged.

To check the cylinder head bottom surface for flatness and distortion, as indicated in the diagram, use a straight edge and a feeler gauge. If distortion exceeds the limit correct by grinding.

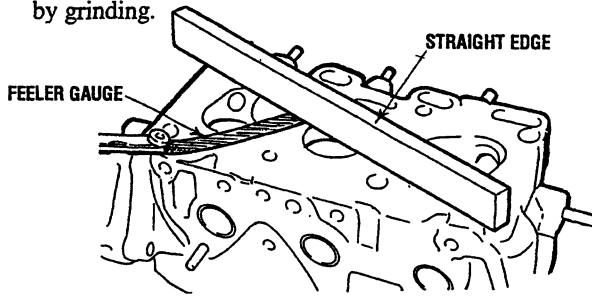

CHECKING CYLINDER HEAD FLATNESS

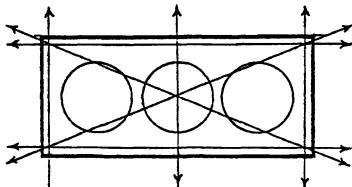

CYLINDER HEAD FLATNESS

Standard 0.0019in (0.05mm) Limit 0.0079in (0.2mm)

CYLINDER HEAD GRINDING LIMIT

0.0079in (0.2mm)

Total resurfacing depth of cylinder head and block

CYLINDER HEAD HEIGHT (NEW)

4.287 - 4.295in (108.9 - 109.1mm)

CAUTION: No more than 0.079in (0.2mm) of stock may be removed from the cylinder head and cylinder block mating surfaces in total.

See the *STANDARDS AND LIMITS CHART* for cylinder head rework dimensions of the valve seat hole.

VALVE ASSEMBLY INSPECTION

Valve Stem/Valve Seat

If the valve stem is bent or worn, replace the valve. Check contact between the valve and valve seat by applying a thin coat of Prussion Blue (or Redhead) on the valve seat contact face, then insert the valve into the valve guide and press-fit the valve on the valve seat. Do not rotate the valve.

Check if the valve seat contact face contacts the center position of the valve contact face. If it is not correct concentric, correct the valve seat. If the margin is out of the limit, replace the valve.

THICKNESS OF VALVE HEAD MARGIN

	Standard	Limit
Intake	0.039in (1.0mm)	0.020in (0.5 mm)
Exhaust	0.051in (1.3mm)	0.031in (0.8mm)

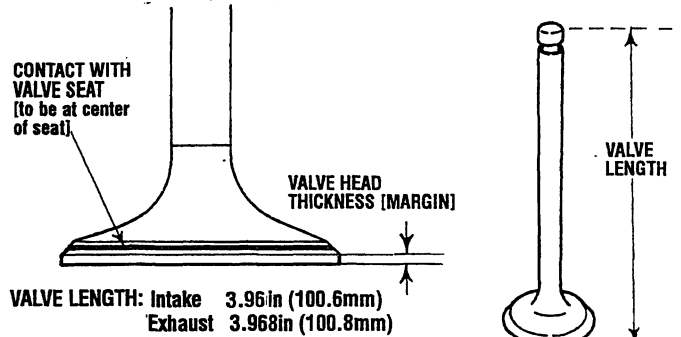

VALVE LENGTH: Intake 3.96in (100.6mm)
Exhaust 3.968in (100.8mm)

VALVE SEAT WIDTH OF CONTACT

Standard 0.035in - 0.051 (0.9 - 1.3mm)

Valve Spring

Measure the free height of the valve spring and replace the spring if it is out of limit.

VALVE SPRING FREE LENGTH

Standard 1.823in (46.3mm) Limit 1.783in (45.3 mm)

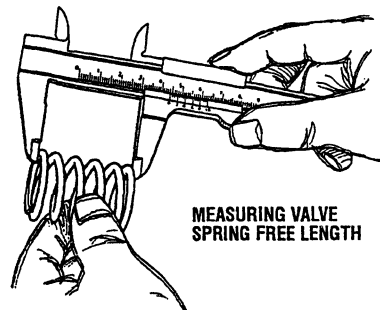

MEASURING VALVE SPRING FREE LENGTH

Also check the spring for squareness and if it exceeds the limit replace the spring.

VALVE SPRING SQUARENESS

Standard less than 2° Limit 4°

Refer to the Standards/Limits chart for additional specifications on valves.

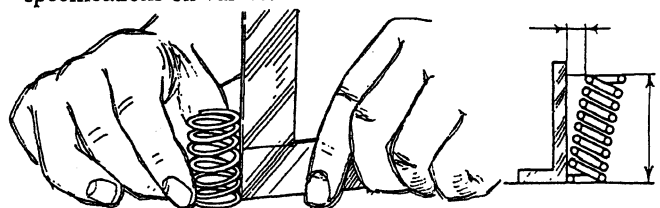

TESTING SQUARENESS/ANGLE

CYLINDER HEAD AND VALVES

Valve Stem and Guides

Measure the clearance between the valve guide and the valve stem and, if the clearance exceeds the limit, replace the valve guide or valve, or replace both.

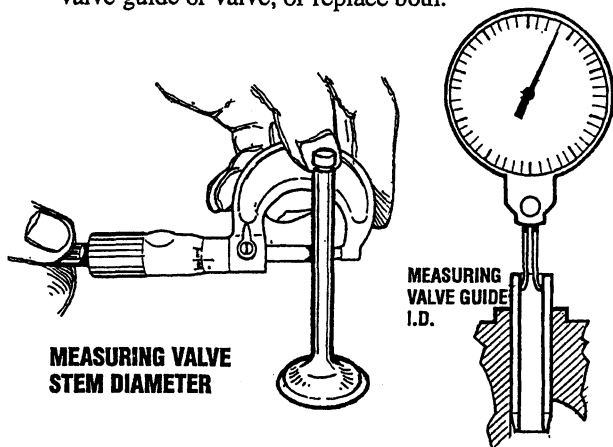

MEASURING VALVE STEM DIAMETER

MEASURING VALVE GUIDE I.D.

VALVE STEM TO VALVE GUIDE CLEARANCE

Standard	Intake	0.008 - 0.0020in (0.02 - 0.5mm)
	Exhaust	0.002 - 0.0033in (0.005 - 0.0085mm)
Limit	Intake	0.0039in (0.15mm)
	Exhaust	0.002 - 0.0033in (0.005 - 0.0085mm)

VALVE STEM OUTER DIAMETER

Standard	Intake	0.2585 - 0.2591in (6.565 - 6.580mm)
	Exhaust	0.2571 - 0.2579in (6.530 - 6.550mm)

Valve Seat Reconditioning

Before correcting the valve seat, check for clearance between the valve guide and the valve. replace the valve guide if necessary.

To recondition, use a valve and seat cutter and a pilot or a seat grinder, repair so that the seat width and seat angle are the specified configuration.

After correction, the valve and the valve seat should be lapped with lapping compound.

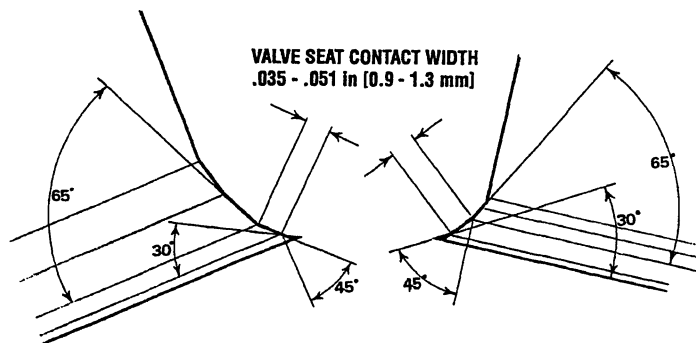

INSTALLATION

Valve Stem Seal

Install the valve spring seat, then using the valve stem seal installer, install a new stem seal to the valve guide.

Do not use the old valve stem seal.

NOTE: Use the installer tool to insert the stem seal, improper installation can cause oil to leak into the cylinder.

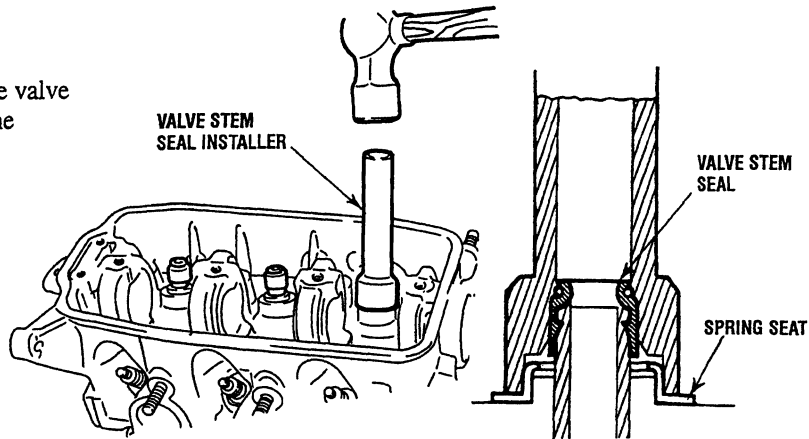

Valve Springs

Install the valve spring with its enamel coated side toward the rocker arm side.

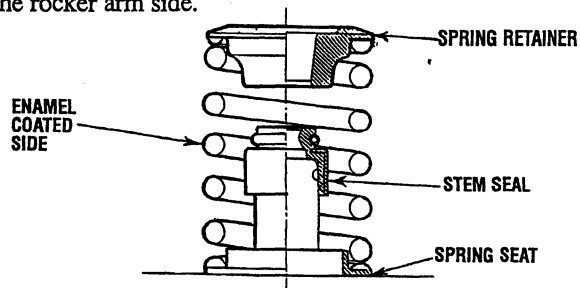

Use the valve spring compressor to compress the valve springs. With the valve spring compressed, remove the retainer locks.

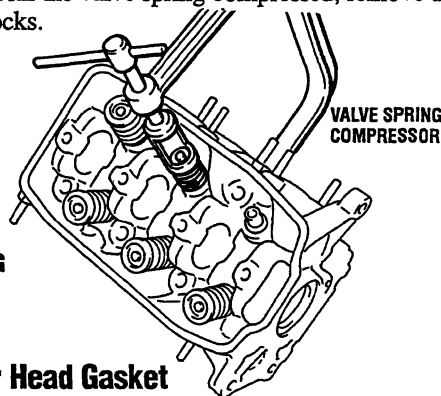

REMOVING RETAINER LOCKS

Cylinder Head Gasket

Clean the residue of gasket and oil from the gasket mounting surface of the cylinder block and the cylinder head.

Place a new cylinder head gasket on the cylinder block facing its identification mark upward.

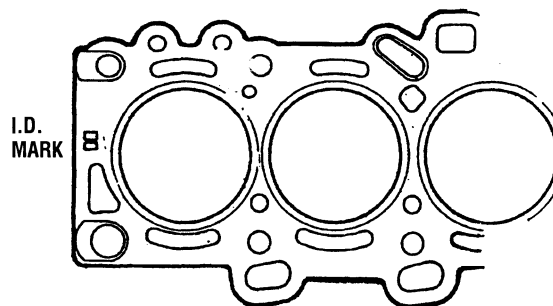

CYLINDER HEAD GASKET

CYLINDER HEAD

Cylinder Head Bolts

Tighten the cylinder head bolts in the order shown in the diagram using a stepped-up tightening torque.

1. Temporarily tighten the bolts in numerical order to 14 - 22ft-lbs (20 - 30 Nm).
2. Tighten the bolts again in numerical order to 29 - 36ft-lbs (40 - 50Nm).
3. Tighten the bolts in numerical order to the specified torque.

CYLINDER HEAD TORQUE 43 -51ft-lbs (60 - 70Nm)

Rocker Cover

Install the rocker cover using a new gasket (slightly coat both sides with clean oil). Gradually tighten the cover bolts to the specified torque making certain the cover gasket is positioned properly.

ROCKER COVER BOLT TORQUE (6mm BOLT)

2.9 - 5.2 ft-lbs (4 - 7Nm)

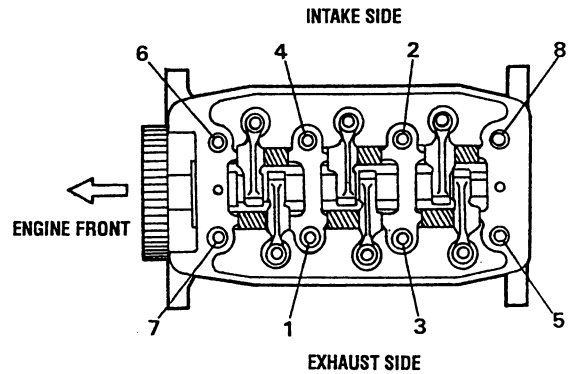

**CYLINDER HEAD BOLTS
TIGHTENING SEQUENCE**

CAMSHAFT AND ROCKER ARMS

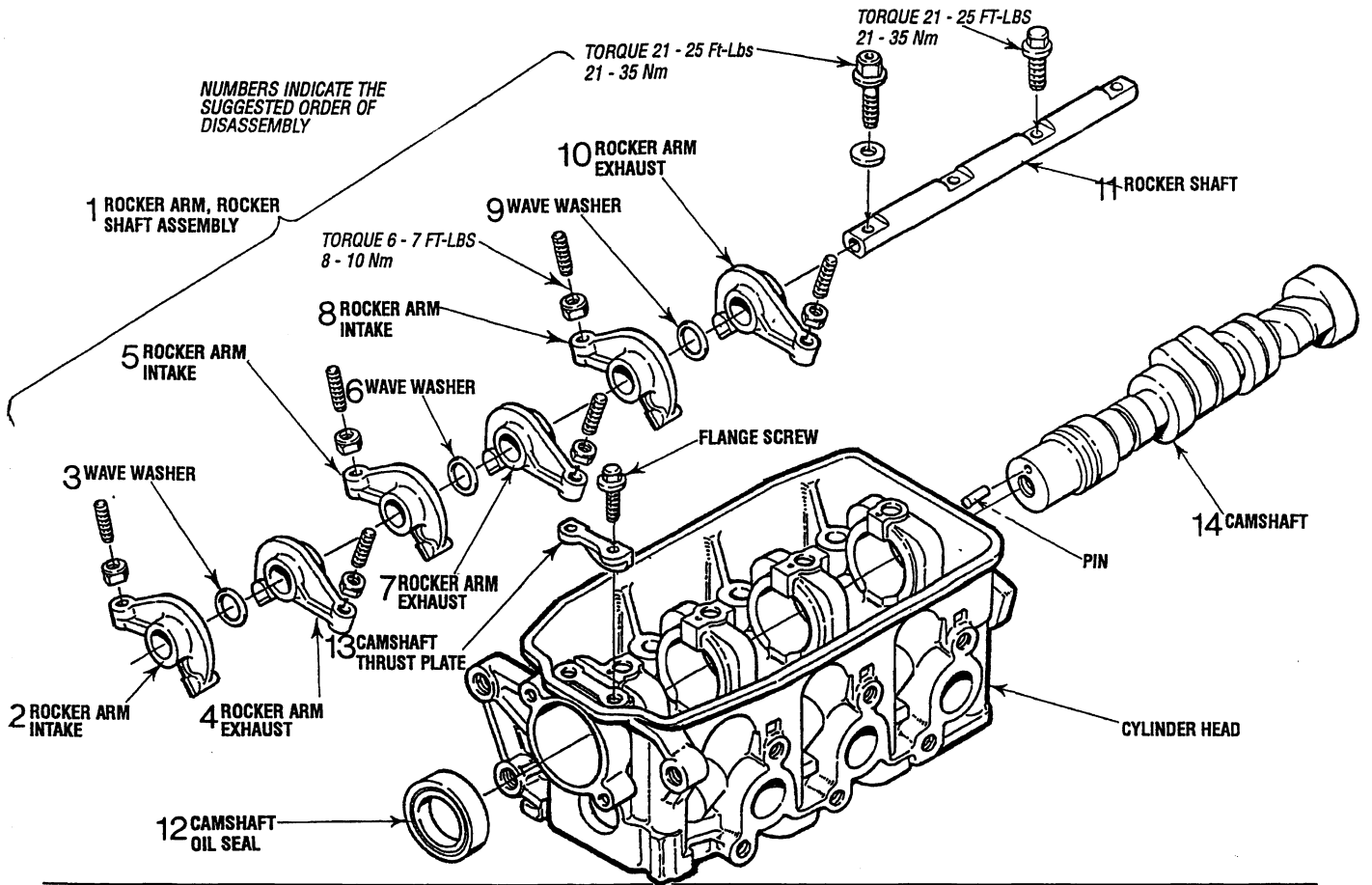

INSPECTING THE CAMSHAFT

1. Visually inspect the camshaft for cracks and damage. If necessary, replace the camshaft.

NOTE: If the damage is slight, you may be able to correct the camshaft with an oil soaked fine emery grindstone. Take special care to not damage the original cam form.

2. Inspect the camshaft journal and, if wearing exceeds the limit, replace the camshaft.

CAMSHAFT JOURNAL DIAMETER

STANDARD 1.6118 - 1.6124in (40.940 - 40.955mm)

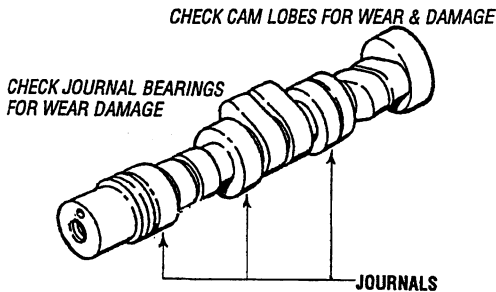

Camshaft

NOTE: If the Journal is seized, also check the cylinder head!

3. Measure the cam height and, if it is less than the limit, replace the camshaft.

	CAMSHAFT HEIGHT	STANDARD	LIMIT
Intake	#1	1.3815in (35.09mm)	1.3618in (34.59mm)
	#2	1.3807in (35.07mm)	1.3610in (34.57mm)
	#3	1.3803in (35.06mm)	1.3606in (34.56mm)
Exhaust	#1	1.3839in (35.15mm)	1.3642in (34.65mm)
	#2	1.3831in (35.13mm)	1.3634in (34.63mm)
	#3	1.3854in (35.19mm)	1.3657in (34.69mm)

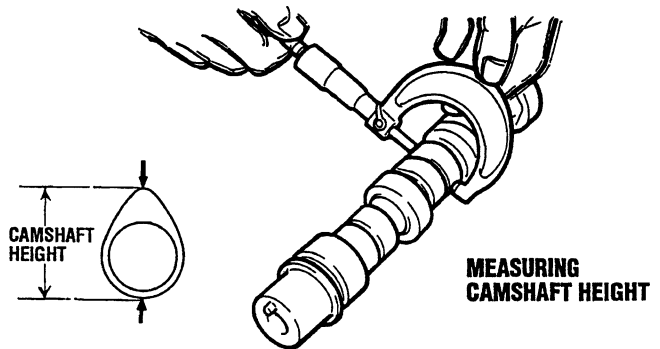

4. Inspect the clearance between the camshaft journal and the camshaft support bore as follows:

- a. Measure the camshaft journal diameter and the camshaft support bore.
- b. Calculate the clearance and replace the camshaft or cylinder head if the clearance exceeds the limit.

BEARING OIL CLEARANCE

STANDARD 0.0018 - 0.0033in (.045 - 0.085mm)

CAMSHAFT AND ROCKER ARMS

Rocker Arm

Check each component part of the rocker arm assembly and carefully inspect the individual rockers where the arrows indicate.

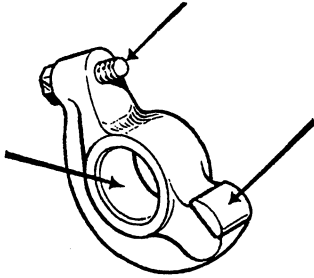

ROCKER ARM INSPECTION

Inspecting Clearance Rocker Arm And Shaft

Check the clearance between the rocker arm and shaft and, if it exceeds the limit, replace the rocker arm or shaft.

ROCKER ARM CLEARANCE (ROCKER ARM TO SHAFT)

Standard	0.0005 - 0.0017in (0.012 - 0.043mm)
Limit	0.004in (0.1mm)

Rocker Shaft

1. Inspect the rocker shaft where the rocker arms sit for water and damage. Replace the shaft if worn.
2. Measure the shaft length and the shaft outer diameter (O.D.). If the shaft fails to meet the standards, replace the shaft.

ROCKER SHAFT LENGTH Standard 9.134in (232mm)

ROCKER SHAFT O.D. Standard 0.6687 - 0.6692in (16.985 - 16.998mm)

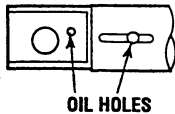

OIL HOLES

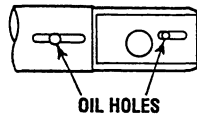

OIL HOLES

INSTALLATION

1. Apply a coating of engine oil to the camshaft journals and cams and insert the camshaft through the rear of the cylinder head.
2. Install the camshaft thrust plate as shown in the diagram tighten the bolts to the specified torque.

THRUST PLATE BOLT TORQUE 7 - 9ft-lbs (10 - 12Nm)

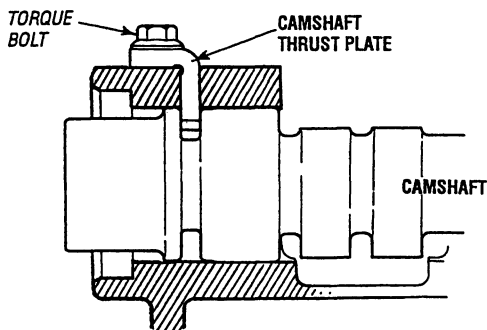

3. Measure the end play of the camshaft by inserting a feeler gauge in the gap between the rear of the thrust plate and the new front camshaft journal.

CAMSHAFT END PLAY

Standard	0.0024 - 0.0055 (0.06 - 0.14)
Limit	0.118 (0.03)

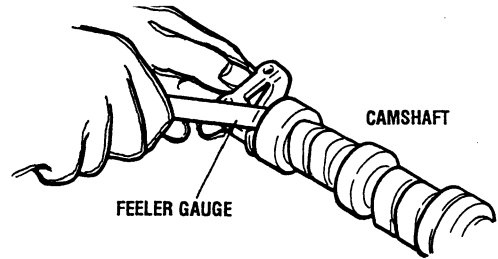

4. Using the oil seal installer tool, install the front oil seal in the cylinder head.

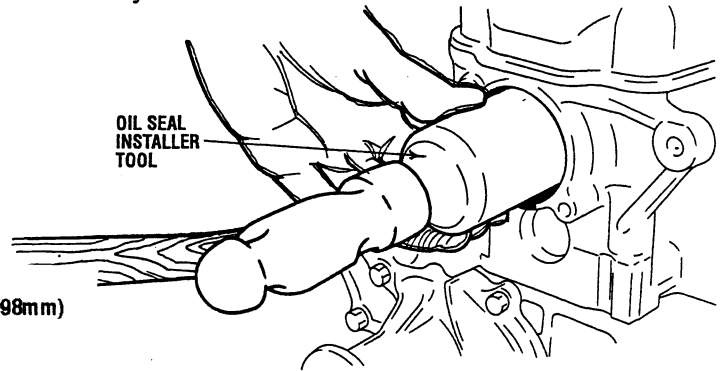

5. Install the rocker arm/rockershaft assembly. Install the rocker shaft so the portion shown in the diagram is located on the front.

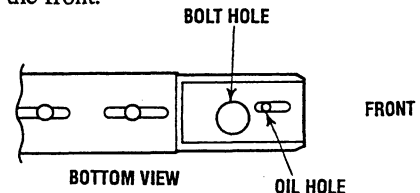

6. Tighten the rocker arm shaft bolts (4 bolts) uniformly and then to the specified torque.

ROCKER ARM SHAFT BOLT TORQUE 21 - 25ft-lbs (29 - 35 Nm)

PISTONS AND CONNECTING RODS

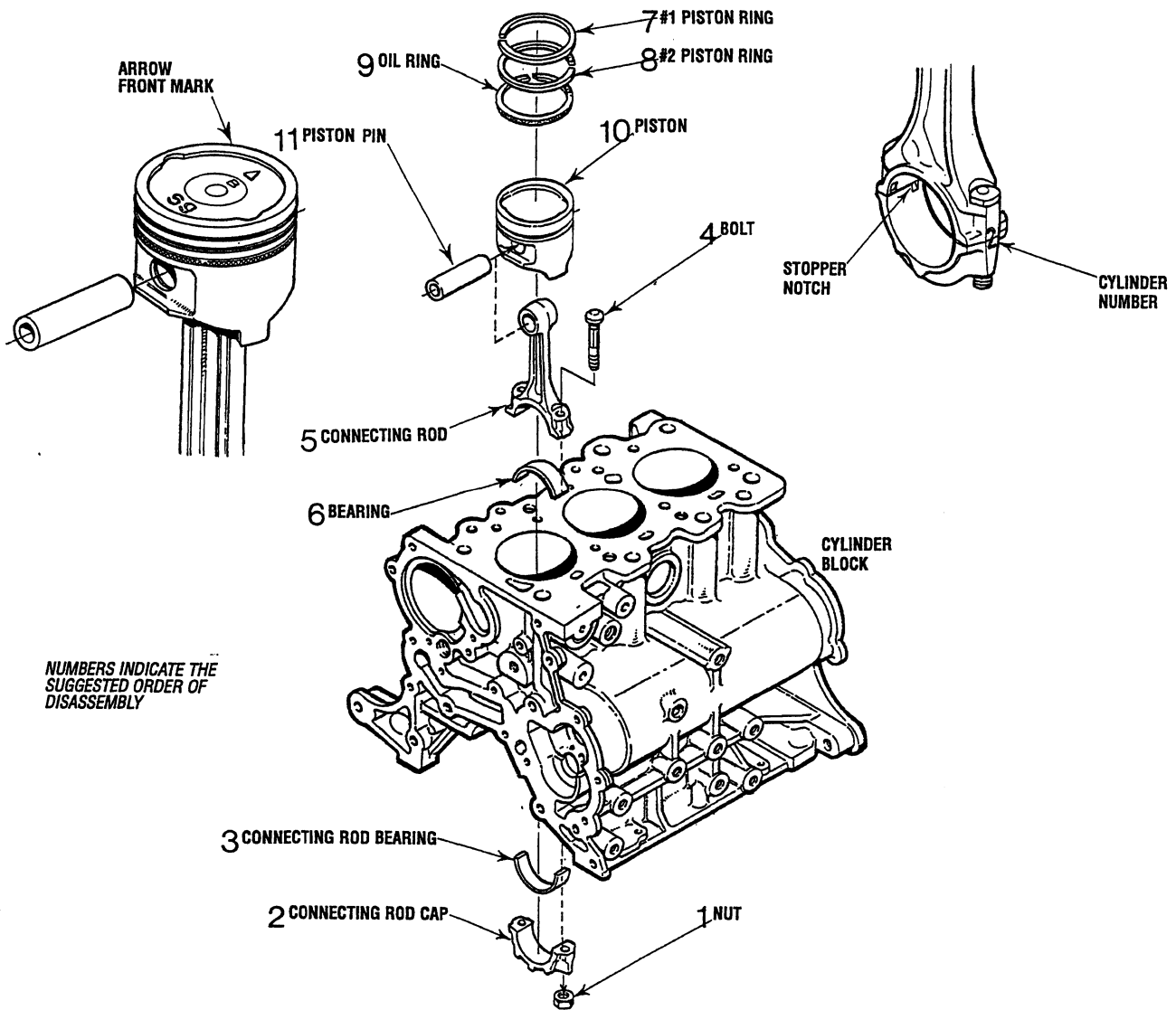

REMOVING THE CONNECTING RODS/PISTONS

Turn the engine over and remove the connecting rod bearing caps and the connecting rod bearings, note the markings on the bearing cap and keep the disassembled parts (connecting rod, rod cap, piston, etc. classified by cylinder. If the marks are worn away be certain to remark them.

Disassemble the Pistons

Using the ring remover, remove the piston rings. While removing the piston rings, note the order they are removed and which side of the ring faces the piston crown.

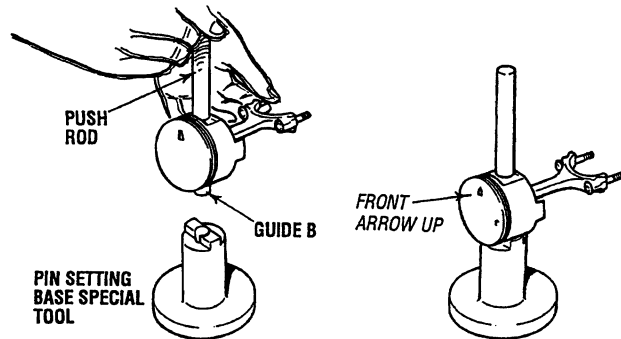
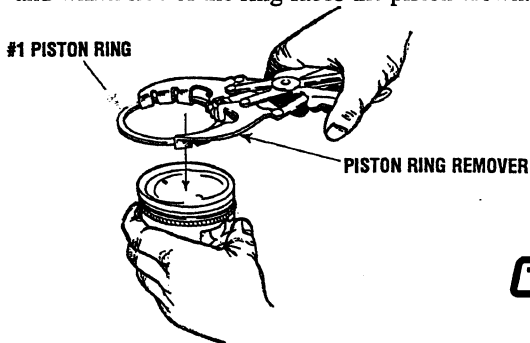

Remove the Piston Pins

Insert the special tool, push the rod, and guide B into the piston pin then set the piston and connecting rod assembly on the pin setting base. Make certain that the front (arrow) stamped on the piston top surface faces upwards. Using a press, drive out the piston pin.

NOTE: Keep the disassembled piston, piston pin and connecting rod in order according to the cylinder number.

PISTONS AND CONNECTING RODS

PISTON PIN INSPECTION

Reinsert the piston pin into the piston hole with your thumb. You should feel a slight resistance, if the bore is misaligned the pin will click or bind as it enters. Try the pin from both sides. Replace the piston if the pin can be too easily inserted or if there is excessive play.

NOTE: The piston pin and piston are replaced as an assembly.

Measure the outside diameter of the piston pin.

PISTON PIN O.D. 0.6300 - 0.6302in (16.001 - 16.007mm)

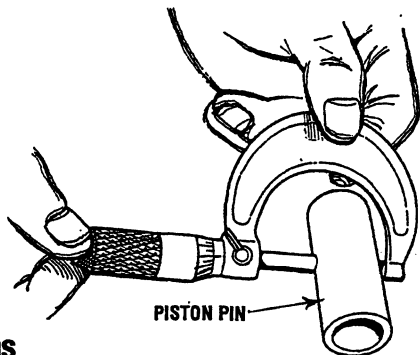

Pistons

Check the piston surfaces for wear, seizure, cracks and streaking. If any damage is evident, replace the piston. Inspect the oil return hole in the oil ring groove and the oil hole in the piston boss. Clean the piston if these are clogged. Check the piston pin hole for signs of seizure or damage. Replace the piston if damage is evident. Measure the piston diameter at 90° (perpendicular) to the pin bore axis.

PISTON O.D. 2.5579 - 2.5591in (64.97 - 65.00mm)

If the piston diameter is less than the standard replace the piston.

NOTE: The piston and piston pin are replaced as an assembly.

Piston Rings

Insert the piston ring into the cylinder bore placing it against the top of the piston head and pressing it in. When it marks a right angle, measure the piston ring gap with a feeler gauge. When the gap is too large, replace the piston ring.

PISTON RING GROOVE

	Standard
No.1	0.0480 - 0.0488in (1.22 - 1.24mm)
No.2	0.0476 - 0.0484in (1.21 - 1.23mm)
Oil	0.1108 - 0.1116in (2.815 - 2.835mm)

PISTON RING END GAP

	Standard	Limit
No.1	0.0059 - 0.0118in (0.15 - 0.30mm)	0.8mm (0.0315in)
No.2	0.0138 - 0.0197in (0.35 - 0.50mm)	0.8mm (0.0315in)
Oil	0.008 - 0.028in (0.2 - 0.7mm)	1.0mm (0.0394in)

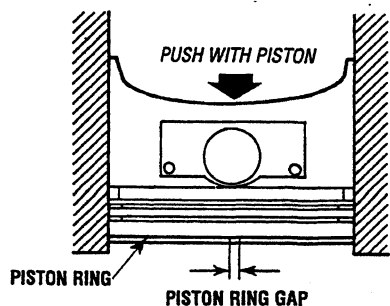

Check the piston ring for damage, wear, seizure and bends replacing the rings if anything unusual is noted. Always replace the piston rings when installing a new piston.

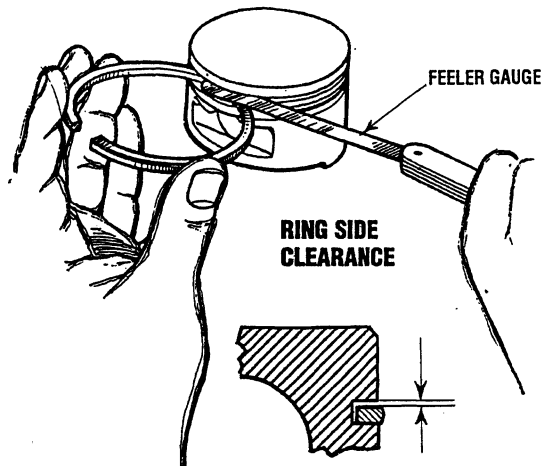

Check the clearance between the piston ring and the ring groove, if it exceeds the limit, replace the rings, the piston or both.

PISTON RING SIDE CLEARANCE

	Standard	Limit
No.1 ring	0.0012 - 0.0028in (0.03 - 0.07mm)	0.0047in (0.12mm)
No.2 ring	0.0008 - 0.0024in (0.02 - 0.06mm)	0.0039in (0.10mm)

Connecting Rod Bearing

Visually check the surface of the bearing. Replace those which are lopsided, streaked or seized. When streaks or seizure are excessive, check the crankshaft. If damage is discovered on the crankshaft, either replace it or reuse after undersize machining. If the connecting rod bearing indicates severe thermal damage, replace the bearing.

Measure the inner diameter of the connecting rod bearing and the outer diameter of the crankshaft pin. If the gap (oil clearance) exceeds the limit, replace the bearing, and, if necessary, the crankshaft...or undersize machine the crankshaft and replace the bearings with an appropriate undersize type.

CONNECTING ROD BEARING OIL CLEARANCE

	Standard	Limit
	0.0009 - 0.0020in (0.022 - 0.052mm)	0.004in (0.1mm)

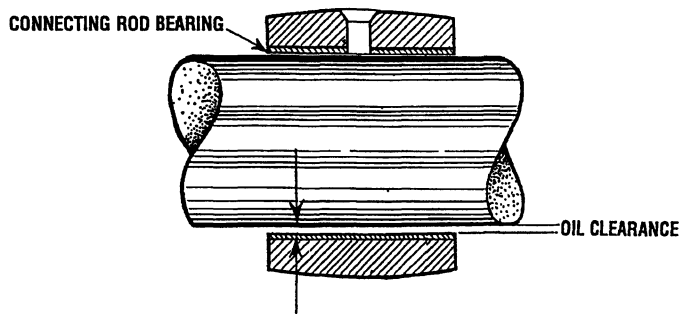

PISTONS AND CONNECTING RODS

NOTE: See Crankshaft/Bearing section for measuring the oil clearance with a Plastigauge.

Use a rod aligner to check the connecting rod for bend and twist.

CONNECTING ROD BEND LIMIT 0.004in (0.01 mm)

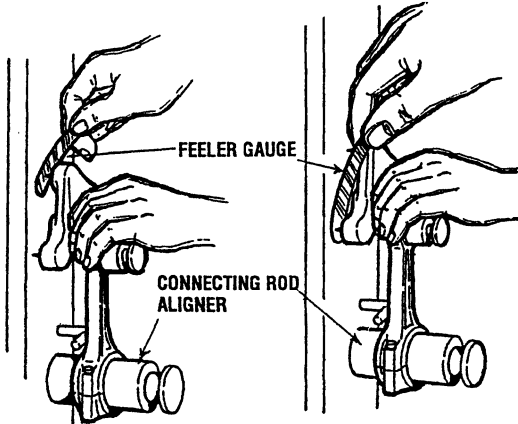

CONNECTING ROD TWIST LIMIT 0.004in (0.1mm)
 CONNECTING ROD BIG END TO CRANKSHAFT SIDE CLEARANCE
 Standard 0.0039 - 0.0098in (0.10 - 0.25mm)
 CONNECTING ROD CENTER LENGTH Limit 0.16in (0.4mm)
 Standard 4.0138 - 4.0178in (101.95 - 102.05mm)

ASSEMBLY

Piston Connecting Rod, Piston

Using the special tool (pin setting base) assemble the piston and connecting rod and press-in the piston pin. First, install the piston pin into the special tool,

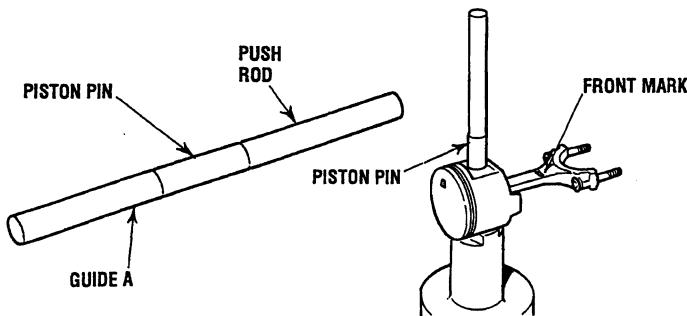

Set up the piston and connecting rod on the piston pin setting base. Make sure that the front marks are facing up. Apply engine oil to the outer circumference of the piston pin and insert the pin, Guide A and the push rod (assembled) into the piston and connecting rod.

Using a press, load the push rod top end and press-fit the piston pin in the connecting rod. The piston pin is press fitted in the specified position by press-fitting the Guide A bottom end surface until it is seated on the bottom surface of the base. If the press-fitting load is out of the specification, replace the pin (piston assembly) or connecting rod, or both.

PISTON PIN PRESS-FITTING LOAD 1102 - 3307lbs (5000 - 15000Nm)

Oil Ring

Assemble the oil ring spacer into the piston ring groove. Then, after assembling the upper side rail, assemble the lower side rail.

NOTE: There is no difference between the upper and lower side rails or the spacers.

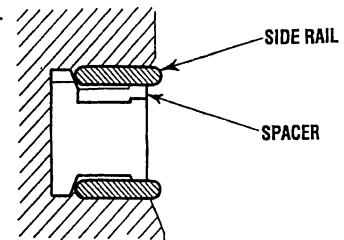

The chart below identifies the color coding on new spacer and side rails according to size.

SPACER AND SIDE RAIL CODING

SIZE	Color Identification
S.T.D.	
0.0098in (0.25mm) Oversize	Two Blue Lines
0.0197in (0.50mm) Oversize	One Red Line
0.0295in (0.75mm) Oversize	Two red lines
0.0394in (1.00mm) Oversize	One Yellow Line

Install the three-piece oil ring in the piston. Then, make certain the side rails move smoothly in both directions. The side rail may be easily installed by pushing it in with your finger after fitting the one end over the piston groove. Do not use an expander ring on the oil ring.

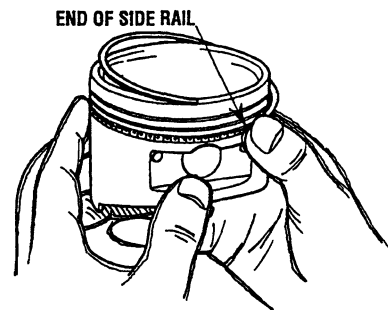

Piston Rings

Use a piston ring expander and install the piston rings with the marker and size marks facing up toward the piston top. Notice the difference in shapes between No.1 and No.2 ring.

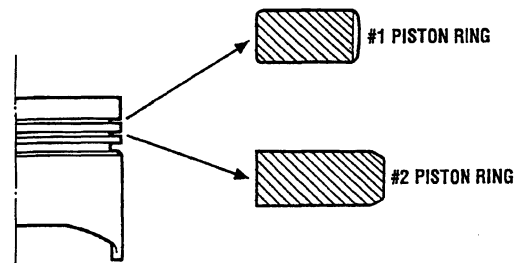

PISTONS AND CONNECTING RODS

Installing the Piston Assembly

Apply an ample amount of oil to the outside surfaces of the piston and the piston rings. Position the piston rings and oil ring (side rail spacer) end gaps as shown.

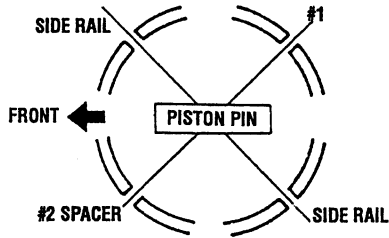

Insert the piston and connecting rod assembly into the cylinder, working from the arrow mark on the piston top toward the camshaft sprocket side.

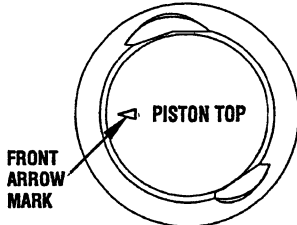

Securely pressing the piston ring with the ring band, insert the piston and connecting rod assembly into the cylinder. Keep in mind that the piston ring may be damaged if hit too strongly.

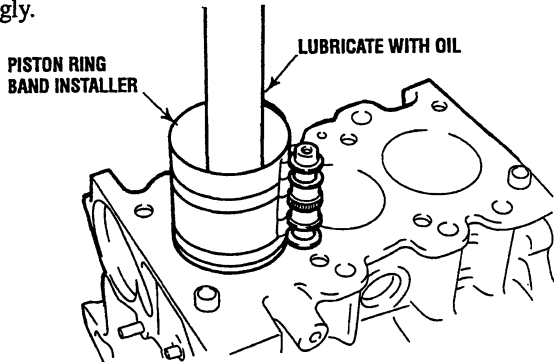

Crankshaft/Bearing Assembly

When the bearings are to be replaced, select the appropriate bearings for assembly according to the identification marks for the crankshaft and the connecting rod.

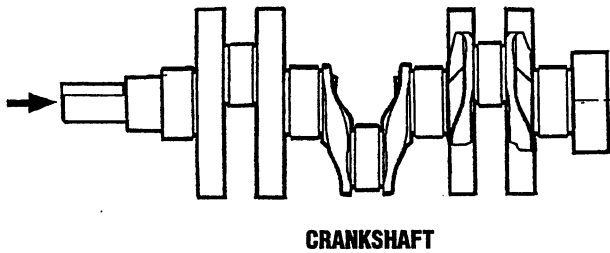

CRANKSHAFT

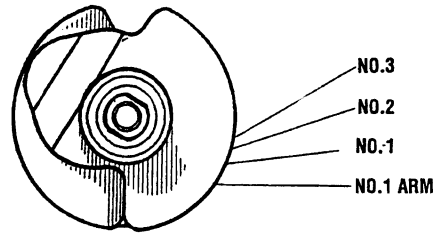

CRANKSHAFT PIN DIAMETER

Identification marks	Journal Diameter
(1) //	1.4171 - 1.4173in (35.995 - 36.000mm)
(2) □	1.4167 - 1.4171in (35.985 - 38.995mm)
(3) □	1.4165 - 1.4167in (35.980 - 35.985mm)

CONNECTING ROD BIG END INNER DIAMETER

Identification Marks	Big End Inner Diameter
○	1.5354 - 1.5356in (39.000 - 39.005mm)
I	1.5356 - 1.5360in (39.005 - 39.015mm)
II	1.5360 - 1.5362in (39.015 - 39.020mm)

CONNECTING ROD BEARING THICKNESS

Identification Color	Bearing Thickness
Brown	0.0586 - 0.0588in (1.488 - 1.493mm)
—	0.0588 - 0.0590in (1.493 - 1.498mm)
Blue	0.0590 - 0.0592in (1.498 - 1.503mm)

CONNECTING ROD BEARING SELECTION TABLE

Crankshaft Pin Identification Marks	Connecting Rod Bearing Identification Marks	
(1) //	I	Brown
	II	Brown
	III	—
(2) □	I	Brown
	II	—
	III	Blue
(3) □	I	—
	II	Blue
	III	Blue

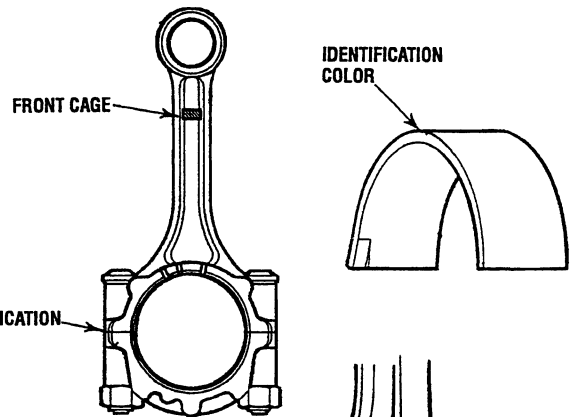

CONNECTING ROD

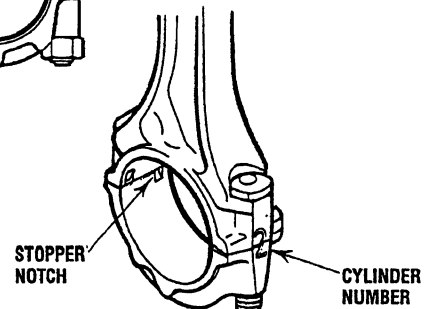

PISTONS AND CONNECTING RODS

Installing the Connecting Rod Bearing Caps

Since the connecting rod cap bolts and nuts are torqued using the plastic area tightening method, the bolts should be examined before reuse. If the bolt threads are “necked down”, the bolt should be replaced.

Necking can be checked by running a nut with fingers to the full length of the bolt threads. If the nut does not run smoothly, the bolt should be replaced.

Before installation of each nut, apply clean engine oil to the thread portion and bearing surface of the nut.

Install each nut to the bolt and tighten it with your fingers. Then tighten the nuts alternately to install the cap properly. Tighten the nuts to the proper torque.

CAP NUT TIGHTENING TORQUE 11+90° turn (15Nm +90° turn)

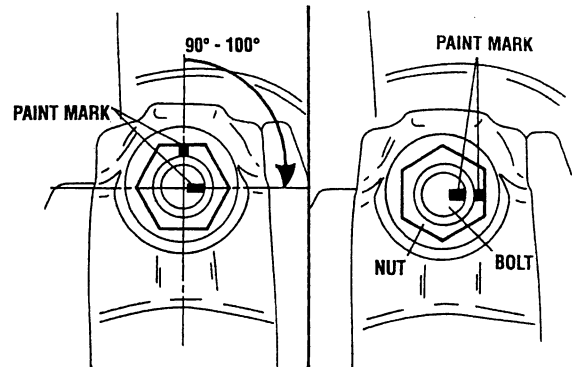

⚠ CAUTION: *If the cylinder head has been installed before installing the connecting rod cap nut, remove the spark plugs.*

Make a paint mark on the head of each nut. Make a paint mark on the bolt end at the position 90° to 100° from the paint mark made on the nut in the direction of the tightening nut.

Give a 90° to 100° turn to the nut and make sure that the paint mark on the nut and that on the bolt are in alignment.

If the nut is turned less than 90°, proper fastening performance may not be expected. When tightening the nut, turn it sufficiently.

If the nut is overtightened (exceeding 100°), loosen the nut completely and then retighten it by repeating the tightening procedure.

FRONT CASE / COUNTERBALANCE SHAFT AND OIL PAN

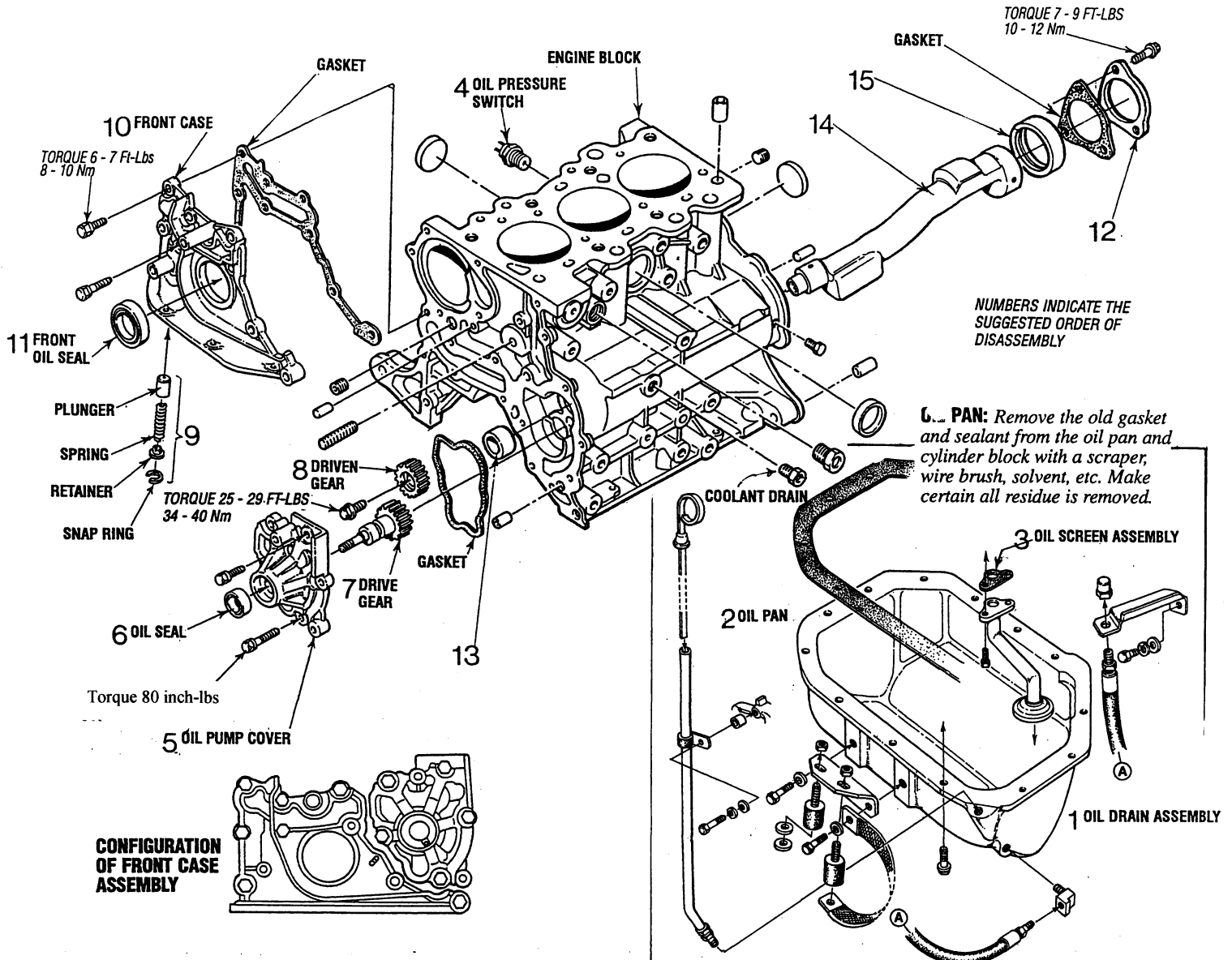

OIL PAN REMOVAL

Remove the oil drain hose assembly. Remove the oil pan bolts and then use the special tool to break the pan seal.

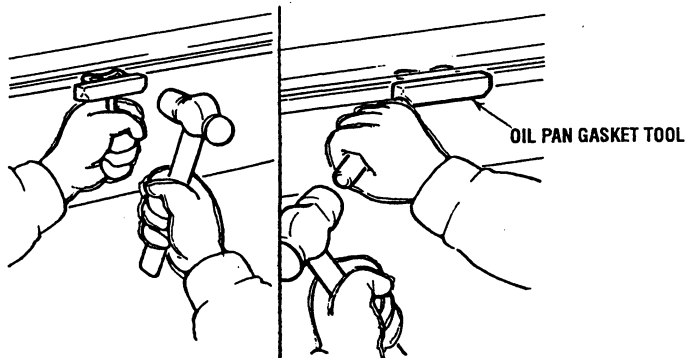

COUNTERBALANCE SHAFT REMOVAL

1. Remove the plug on the cylinder block and insert an 0.32in (8mm) rod into the hole to lock the counterbalance shaft.

2. Remove the oil pump cover and gasket. Discard the gasket.
3. Remove the oil pump driven gear tightening flange bolts to release the counterbalance shaft.
4. Remove the counterbalance shaft. Drive it from the front.

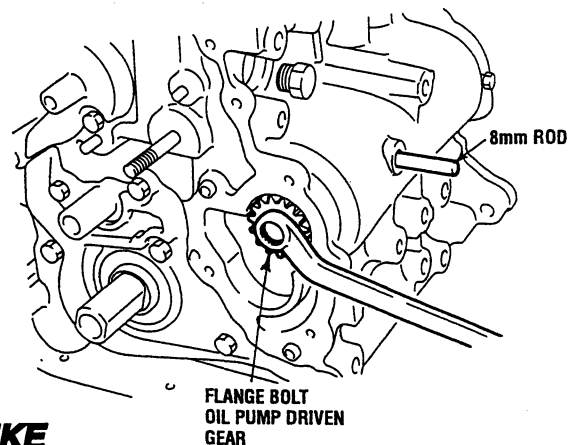

FRONT CASE / COUNTERBALANCE SHAFT AND OIL PUMP

- Using a special tool drive the counterbalance shaft front bearing from the cylinder block.

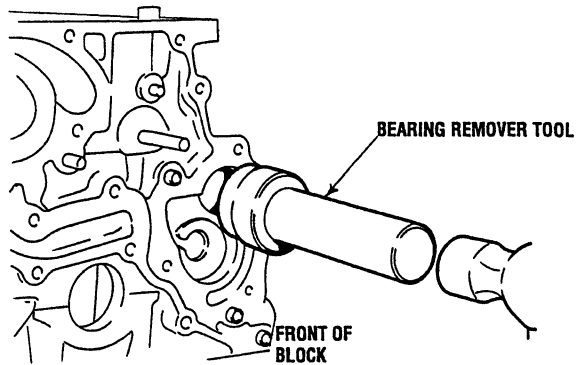

- Use the same tool and drive the counterbalance shaft rear bearing from the cylinder block.

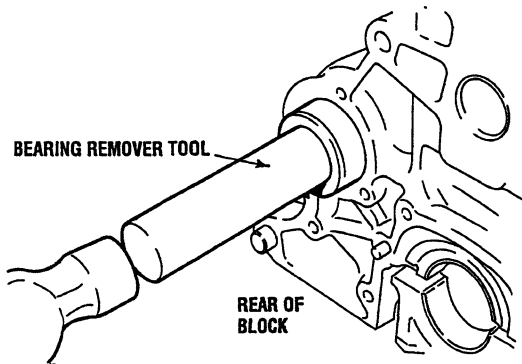

OIL PUMP ASSEMBLY - INSPECTION

Fit the oil pump gear into the cylinder block, then, using a feeler gauge, check the clearance with the body at the points indicated in the diagram below.

DRIVEN GEAR BODY CLEARANCE STANDARD

- A. 0.0161 - 0.0266in (0.410 - 0.675mm)
- B. 0.0051 - 0.0069in (0.130 - 0.175mm)

DRIVE GEAR BODY CLEARANCE STANDARD

- C. 0.0173 - 0.0276in (0.44 - 0.70mm)
- D. 0.0059 - 0.077in (0.150 - 0.195mm)

DRIVEN GEAR SIDE CLEARANCE .0024 - 0.0047in (0.06 - 0.12mm)

DRIVE GEAR SIDE CLEARANCE 0.0027 - 0.0051in (0.07 - 0.13mm)

Using a straight edge, check the side clearance at the point indicated in the illustration with a feeler gauge.

There should be no uneven wear on the contact surfaces of the cylinder block or on the pump gear side of the pump cover.

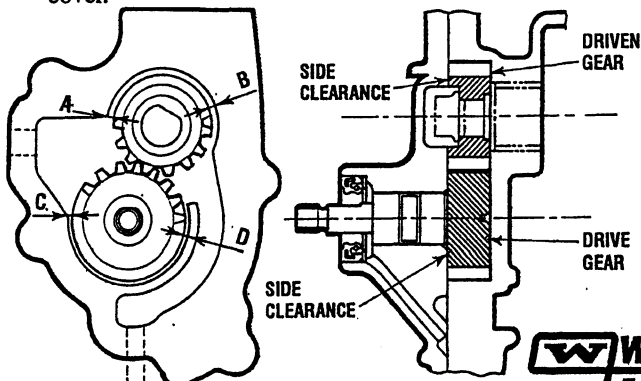

FRONT CASE - INSPECTION

Check the front case for cracks or other damage also inspect the oil holes. If the oil holes are clogged, use compressed air or solvent to clean them out.

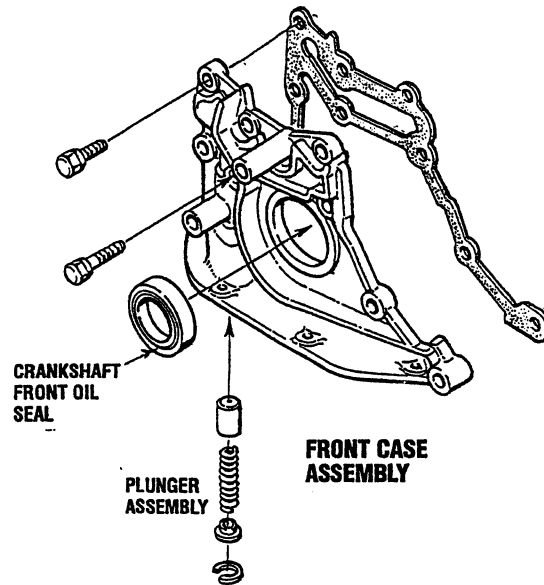

CRANKSHAFT FRONT OIL SEAL - INSPECTION

Check the oil seal for wear and damage. Inspect the oil seal lip for hardening. If there any signs of wear, replace the seal.

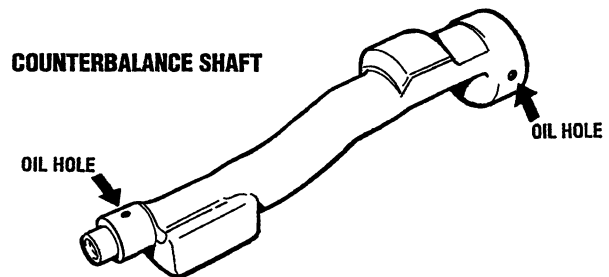

COUNTERBALANCE SHAFT - INSPECTION

Inspect the oil holes for clogging and clean if necessary. Inspect the shaft journal for seizure, damage and its contact with the bearing. Check the counterbalance shaft oil clearance. Replace the counterbalance shaft if it fails to meet the standards.

COUNTERBALANCE SHAFT STANDARDS

Front Journal Diameter	0.7869 - 0.7874in (19.987 - 20.000mm)
Rear Journal Diameter	1.7317 - 1.7322in (43.984 - 44.000mm)
Front Journal Oil Clearance	0.0014 - 0.0027in (0.035 - 0.068mm)
Rear Journal Oil Clearance	0.0014 - 0.0028in (0.035 - 0.071mm)

FRONT CASE / COUNTERBALANCE SHAFT AND OIL PUMP

INSTALLATION

Counterbalance Rear Bearing

1. Install the special tool guide pins (bearing Installer) in the tapered hole of the cylinder block as shown.

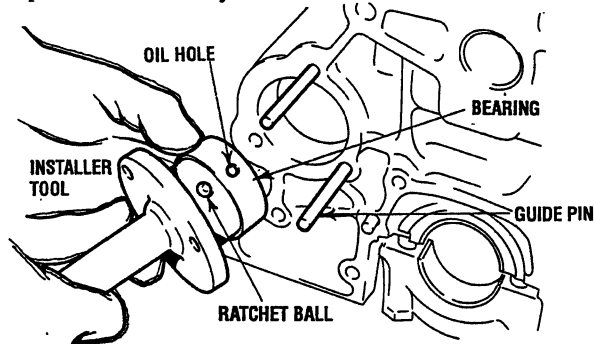

2. Mate the ratchet ball of the bearing in the oil hole of the rear bearing and install the bearing in the bearing installer.
3. Apply clean engine oil to the outer circumference of the bearing and the bearing hole in the cylinder block.
4. Insert the installer by mating it with the guide pins and press-in the bearing.

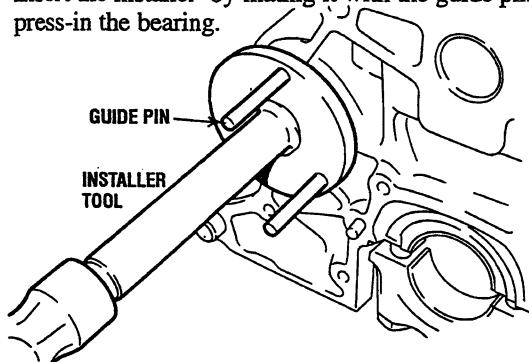

Counterbalance Front Bearing

1. Apply engine oil to the bearing outer circumference and the bearing hole in the cylinder block.
2. Press-in the front bearing using the installer tool.

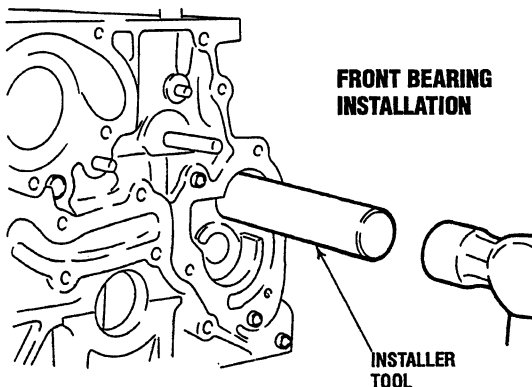

Crankshaft Oil Seal

1. Apply oil to the crankshaft front oil seal lip inner circumference, and using the special tool, knock the oil seal into the front case.

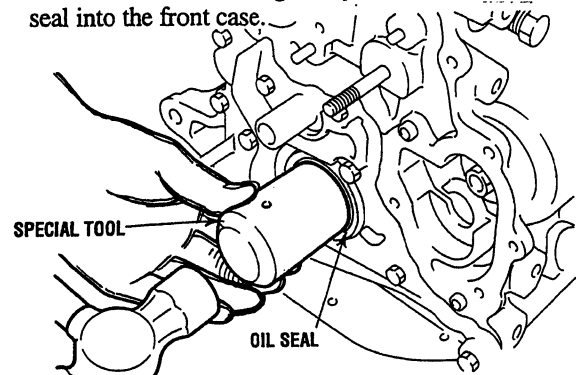

Front Case Assembly

Install the front case assembly through the gasket and tighten the bolts to the specified torque.

FRONT CASE BOLTS TORQUE 6 - 7ft.lbs. (8 - 10 Nm)

There are two different length front case bolts. Make certain they are positioned properly. See the diagram.

NOTE: When installing the front case assembly, apply oil to the inner circumference of the oil seal lip. When installing the front case assembly take care not to damage the oil seal lip on the stepped up portion of the front end of the crankshaft.

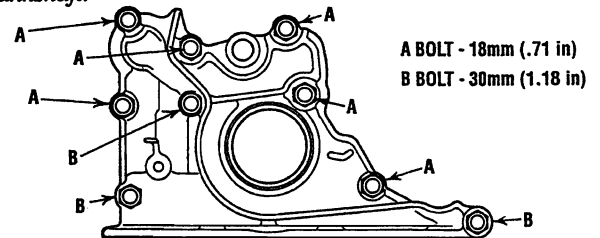

Oil Pump Driven Gear

1. Apply an ample amount of clean engine oil to the oil pump driven gear and insert it so that the timing mark is positioned as shown.
2. Using the same hole on the side of the cylinder block, reinsert the 8mm rod to lock the counterbalance shaft. Then tighten the flange bolt to the specified torque.

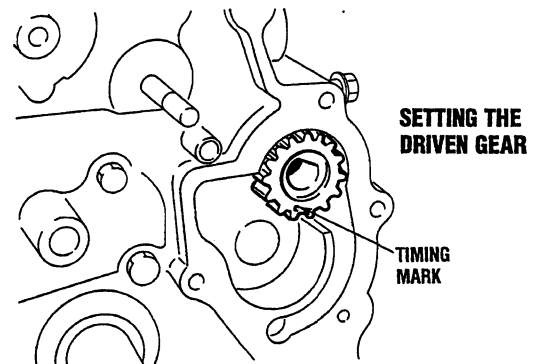

DRIVEN GEAR FLANGE BOLT TORQUE

25 - 29ft.lbs. (34 - 40Nm)

FRONT CASE AND OIL PUMP

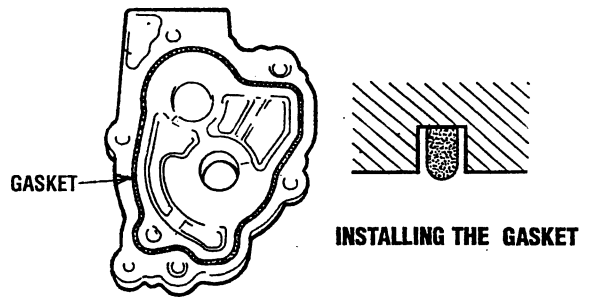
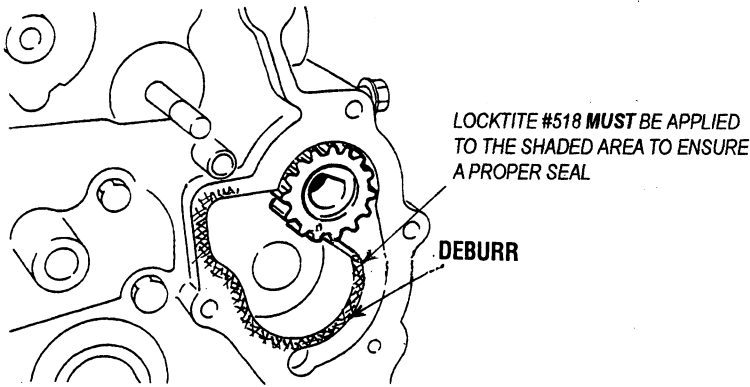

Oil Pump Cover

Re-install the pump cover. Press or lightly tap the cover onto the alignment sleeves. the two long bolts go where the sleeves are - install these bolts first. Install the rest of the bolts in a criss-cross pattern. **Torque the oil pump cover bolts to 80 inch-lbs.**

NOTE: Deburr this edge area as shown. Clean off all metal from the deburring process and clean with a cleaning agent. Wipe dry with a clean cloth and use compressed air to blow dry. the block surface and oil pump cover must be clean and free of oil.

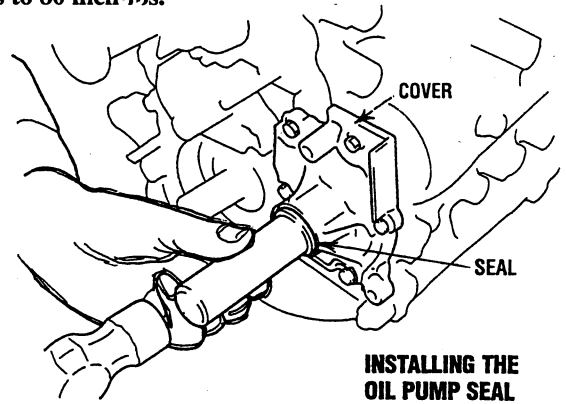
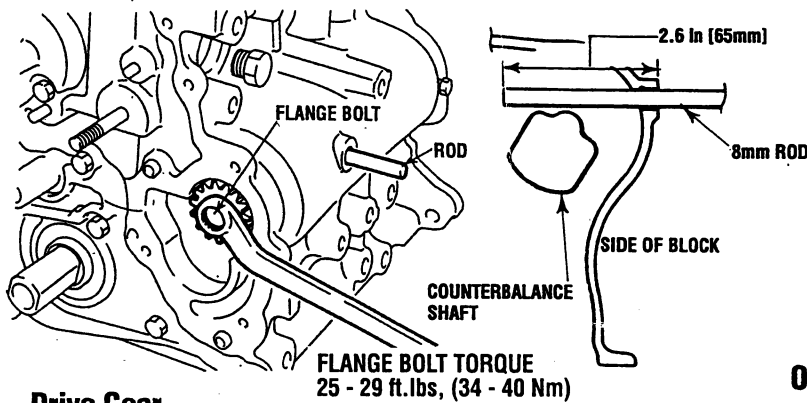

Oil Pump Seal

Press the seal into the oil pump cover flush with the surface using the seal installer tool.

Drive Gear

Align the timing marks and install the oil pump drive gear to the cylinder block.

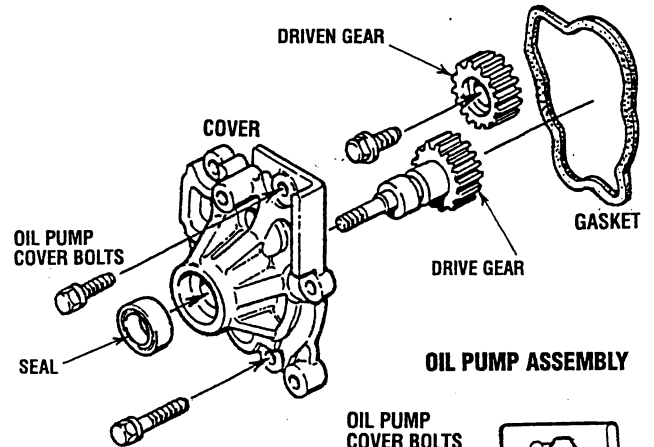
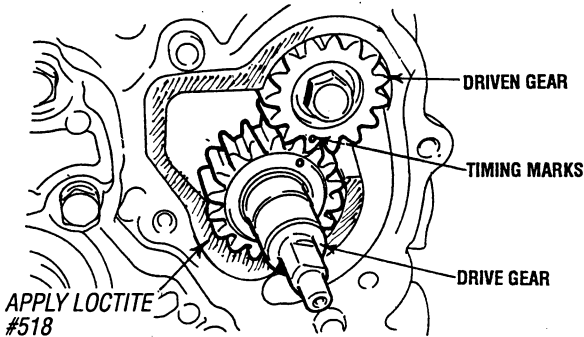

Oil Pump Block Surface

Apply a very small bead of LOCTITE #518 to the engine block surface as shown. Spread it into a thin, even layer on the surface. Remove any excess.

Oil Pump Cover Gasket

Fit a new oil pump cover gasket into the groove in the oil pump cover. The flat side of the gasket is positioned against the pump cover.

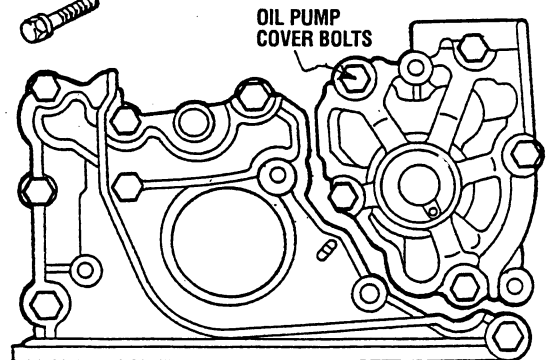

FRONT CASE CONFIGURATION

CRANKSHAFT / BEARINGS AND OIL SEAL

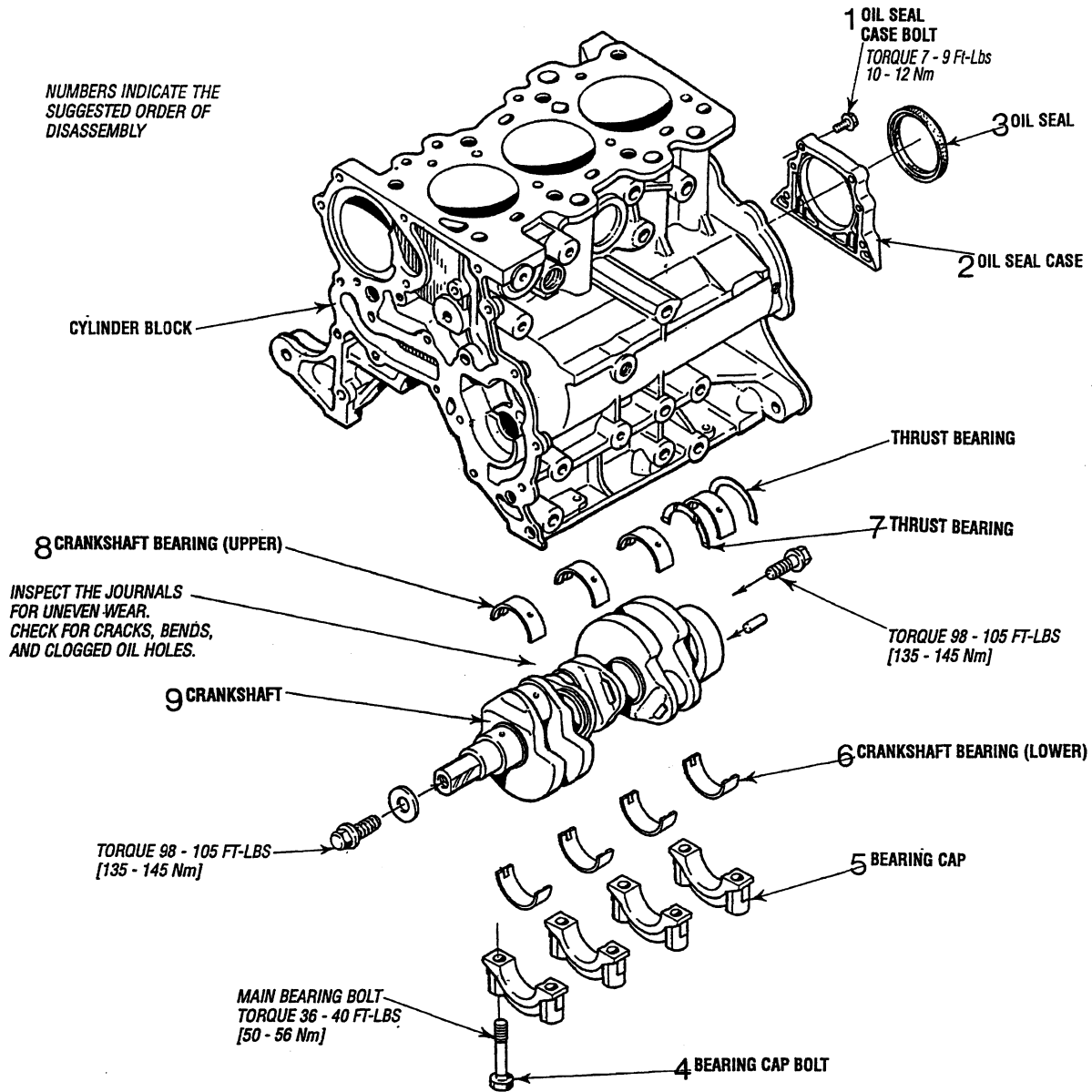

CRANKSHAFT INSPECTION

1. Check the journals and pins for damage, seizure and cracks. Check the journals contact surface for uneven wear and replace if badly damaged.
2. Measure the outside diameter of the journal and the inside diameter of the main bearing. If the clearance (oil clearance) exceeds the limit, replace the main bearing and also the crankshaft, if necessary. Otherwise, fabricate an undersized crankshaft and replace the main bearing with an undersized one.

Standard
0.0008 - 0.0018in (0.021 - 0.045mm)

Limit
.004in (0.1mm)

3. When grinding the crankshaft to under-size, take note of the "R" dimensions of the fillets of the journal and pin area.

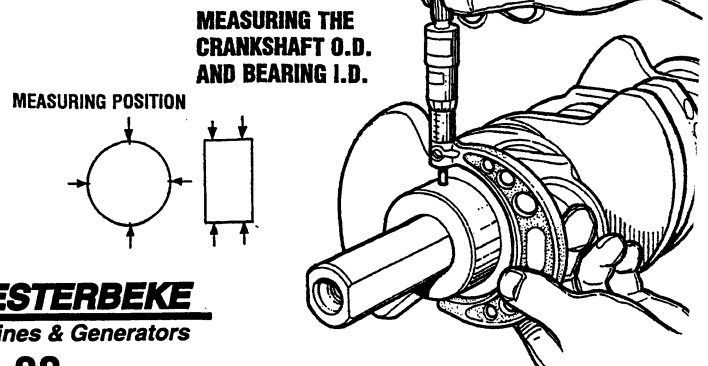
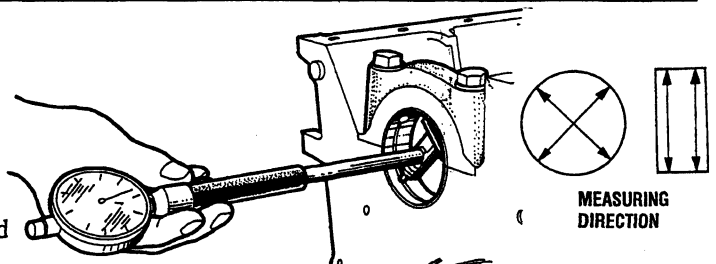

CRANKSHAFT/ BEARING AND OIL SEAL

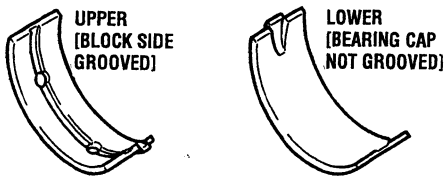

CRANKSHAFT BEARINGS

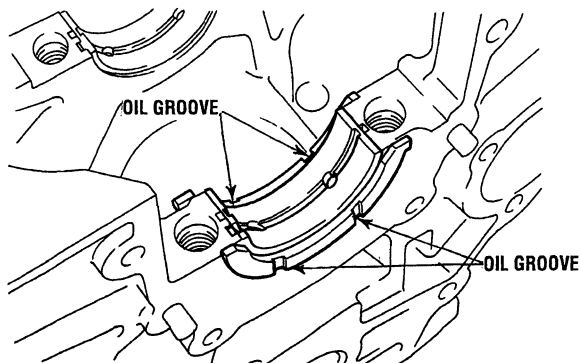

INSTALLING THE THRUST BEARINGS

1. Apply a coat of oil to the thrust bearing and install so that the oil groove faces outward as illustrated.

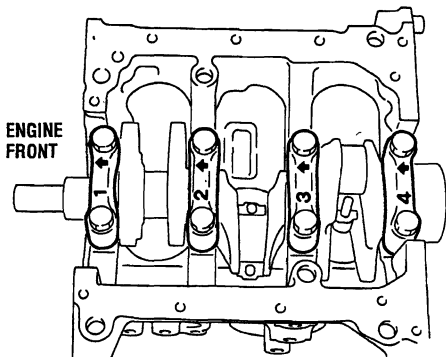

2. Install the bearing cap paying careful attention to the cap number and the arrow mark. Apply oil to the bolt threads.
3. Tighten the bearing cap to the specified torque.

BEARING CAP BOLT TORQUE 36 - 40 ft-lbs (50 - 55Nm)

MEASURING END PLAY

Push the crankshaft to the rear. Then, insert a feeler gauge in the gap between the crankshaft journal side surface and the thrust bearing end surface to measure the end play.

CRANKSHAFT END PLAY: 0.0020 - 0.0098in (0.05 - 0.25mm)

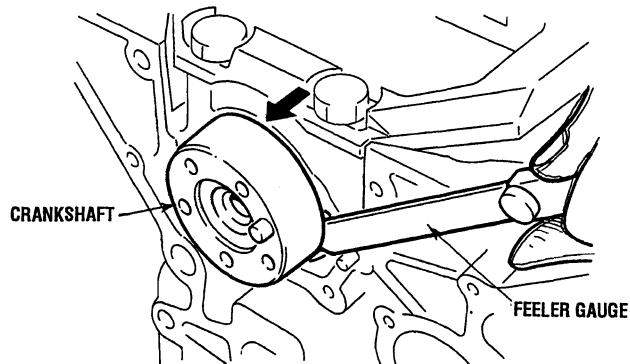

CRANKSHAFT REAR OIL SEAL

1. Apply engine oil to the rear cover and to the oil seal.
2. Press the oil seal into the seal case using the special tool.

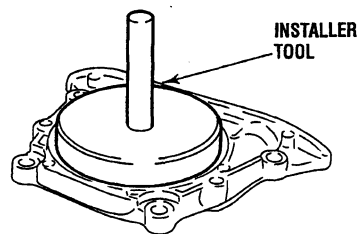

3. Install the oil seal case into the cylinder block through the gasket. (If there is no gasket, coat with sealant.) The entire circumference of the oil seal lip should be coated with clean engine oil.

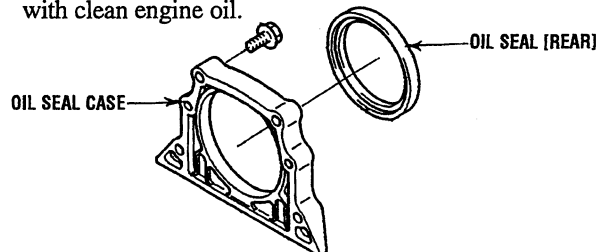

NOTE: Make certain the lips of the oil seal are not turned up.

OIL CASE BOLT TORQUE: 7 - 9 Ft-lbs (10 - 12Nm)

CRANKSHAFT, BEARING AND OIL SEAL

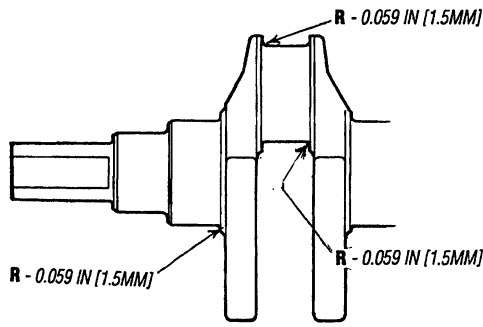

MEASURE THE CRANKSHAFT OIL CLEARANCE

The crankshaft oil measured by using a plastic gauge as follows:

1. The oil and grease and other foreign matters form the crankshaft journal and bearing inner surface.
2. Install the crankshaft.
3. Cut the plastic gauge to the same length as the width of the bearing and place it on the journal in parallel with its axis.
4. Gently place the main bearing cap over it and tighten the bolts to the specified torque.
5. Remove the bolts and gently remove the main bearing cap. Measure the width of the smashed plastic gauge (at its widest section) by using the scale printed on the plastic gauge.

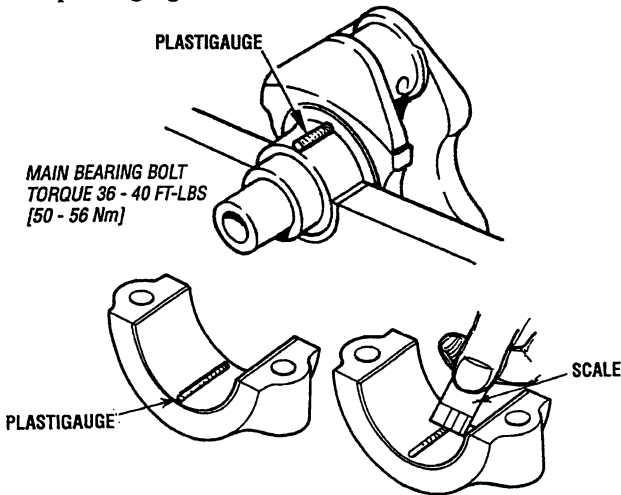

INSPECTING THE CRANKSHAFT REAR OIL SEAL

1. Inspect the oil clearance lip for wear or damage. Check the rubber portion for deterioration and hardening. Replace the seal if at all suspect.
2. Check the oil case for cracks and damage. If here is damage, replace the case.

CRANKSHAFT BEARINGS SPECIFICATIONS

Upper and Lower

When the bearings are to be replaced, select the correct ones and install them in positions according to the identification marks stamped on the crankshaft and the top surface of the cylinder block.

CRANKSHAFT JOURNAL DIAMETER

Identification Marks	Journal Diameter
1	1.5746 - 1.5748 in (39.994 - 40.000mm)
2	1.5743 - 1.5746 in (39.988 - 39.994mm)
3	1.5741 - 1.5743 in (39.982 - 39.988mm)

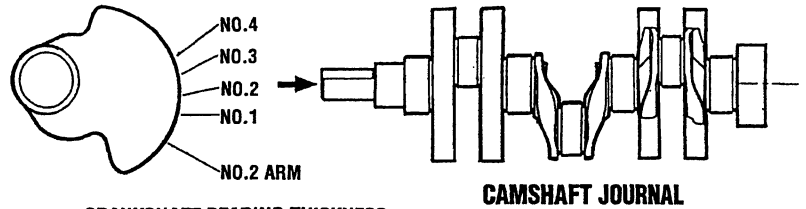

CRANKSHAFT BEARING THICKNESS

Identification Colors	Bearing Thickness
brown	0.0783 - 0.0784 in (1.988 - 1.991mm)
—	0.0784 - 0.0785 in (1.991 - 1.994mm)
blue	0.0785 - 0.0786 in (1.994 - 1.997mm)
yellow	0.0786 - 0.0787 in (1.997 - 2.000mm)
green	0.0787 - 0.0789 in (2.000 - 2.003mm)

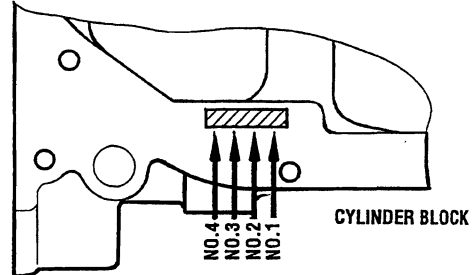

CYLINDER BLOCK BEARING DIAMETER

Identification Marks	Bearing Inner Diameter
O	1.7323 - 1.7325 in (44.000 - 44.006mm)
I	1.7325 - 1.7328 in (44.006 - 44.012mm)
II	1.7328 - 1.7330 in (44.012 - 44.018mm)

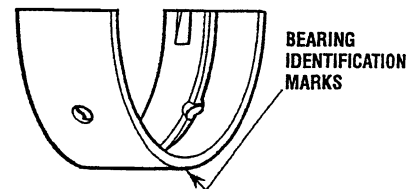

CRANKSHAFT BEARING SELECTION CHART

Crankshaft Journal Identification Marks	Crankshaft Bearing Identification Marks	Cylinder Block Bearing Identification Marks
1	brown —	O I II
2	blue yellow	O I II
3	blue yellow green	O I II

CYLINDER BLOCK INSPECTION AND PISTON CLEARANCE

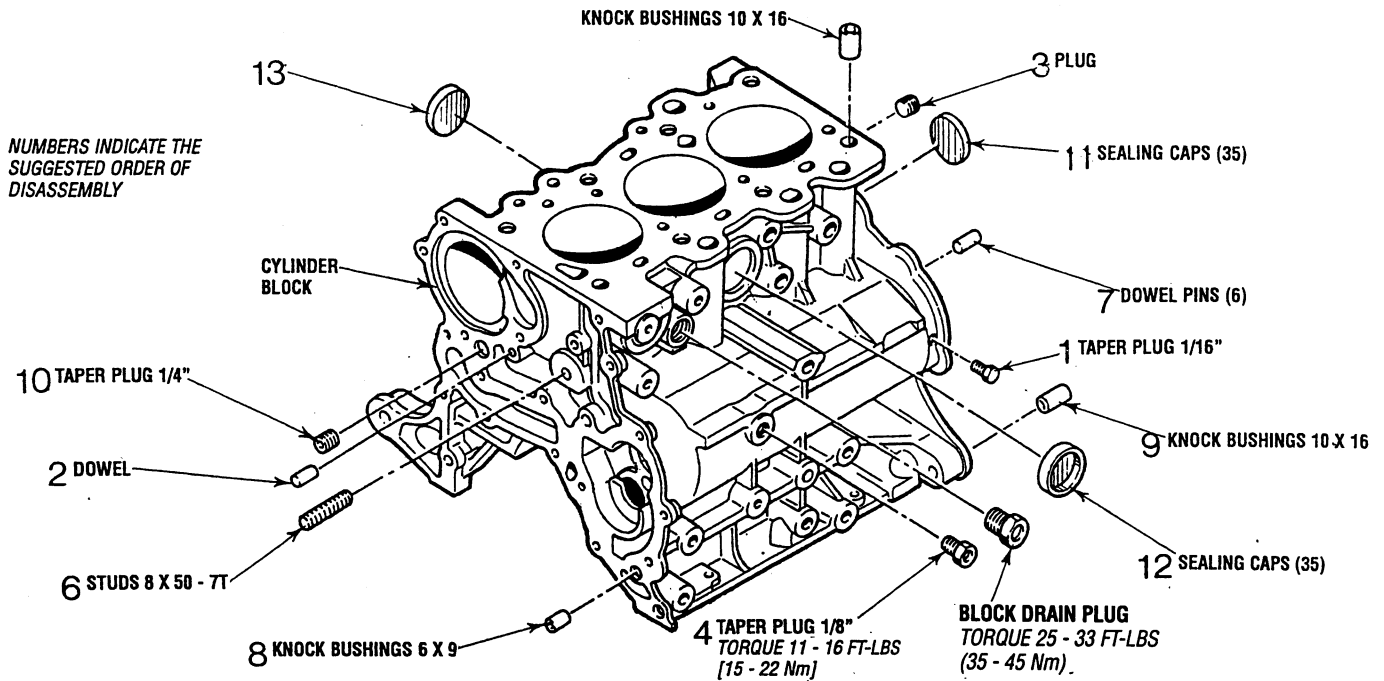

CYLINDER BLOCK INSPECTION

1. Before inspecting, clean the cylinder block to ensure that the water and oil holes are not plugged. If clogged, clear with compressed air.
2. Check for cracks and damage. Use a flaw detecting compound as needed. Replace the block if defective.
3. Inspect the mating surface. Using a straight edge and feeler gauge measure the flatness of the top surface. Grind or replace if the limit is exceeded.

FLATNESS STANDARD VALUE: 0.0020 in (0.05 mm)
LIMIT: 0.004 in (0.1 mm)

4. Inspect the cylinder bore. Using a cylinder gauge, measure the bore at six places (as shown in the diagram). Calculate the difference between the max. and min. values. If worn or damaged, rebore or replace the cylinder.

CYLINDRICITY STANDARD VALUE: 0.004in (0.01mm) or less
CYLINDRICITY BORE: 2.5591 - 2.5602in (65.00 - 65.03mm)
LIMIT CYLINDRICITY: 0.0008in (0.02mm)

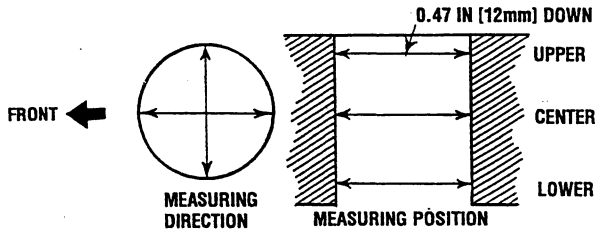
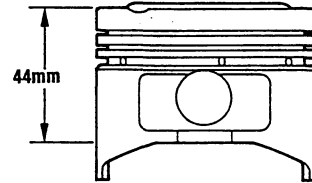

CHECKING THE PISTON CLEARANCE

Calculate the difference between the minimum cylinder bore in the thrust direction and the piston outer diameter shown in the illustration. If the difference exceeds the specified range, replace the piston or cylinder block, or rebore the cylinder.

PISTON TO CYLINDER CLEARANCE STANDARD:
0.0008 - 0.0016 in (0.0 - 0.04 mm)

BORING THE CYLINDER

1. Select an oversize piston based on the cylinder with the maximum bore and maximum damage depth.
2. Using the outer diameter (at the specified measurement point) of the selected oversize piston, calculate the boring dimension.

Boring dimension =
(Piston O.D.) + (piston clearance) - (honing margin : 0.0008in (0.02mm))

OVERSIZE PISTON OUTSIDE DIAMETER AND CYLINDER
(INNER DIAMETER FINISH DIMENSION (REF))

Size	Mark	Piston Dia.	Cylinder Inner Dia.
0.25 O.S.	25	2.5677 - 2.5689in (65.22 - 65.25mm)	2.5693 - 2.5697in (65.26 - 65.27mm)
0.50 O.S.	50	2.5776 - 2.5787in (65.47 - 65.50mm)	2.5791 - 2.5795in (65.51 - 65.52mm)
0.75 O.S.	75	2.5874 - 2.5886in (65.72 - 65.75mm)	2.5890 - 2.5894in (65.76 - 65.77mm)
1.00 O.S.	100	2.5972 - 2.5984in (65.97 - 66.00mm)	2.5988 - 2.5992in (66.01 - 66.02mm)

3. Bore the cylinder to obtain the calculated dimensions.
- 4.hone to finish the cylinder inner diameter.
5. Check again for cylindricity and piston clearance.

COOLANT CIRCULATING PUMP

REMOVING THE COOLANT PUMP

1. Loosen the belt guards thumbscrews and remove the engine's belt guard from its brackets at the front of the engine.
2. Ease the belt tension by releasing the raw water pump and remove the engine drive belt [on carburetor models it will be necessary to remove the governor belt].
3. Unscrew the five bolts that hold the pump to the engine and remove the coolant pump and its gasket. Note that the pulley is an integral part of the pump assembly.

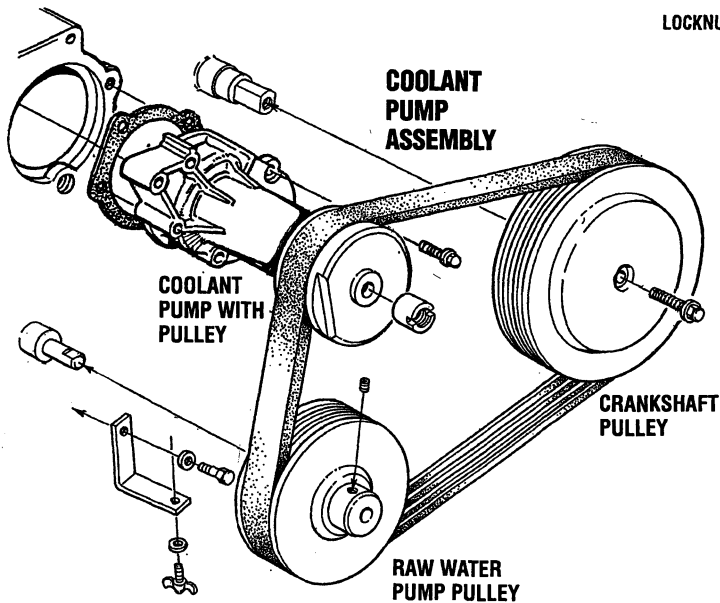

INSPECTION

Carefully check the pump body and impeller for cracks and damage. Inspect the weep holes for signs of water leakage and rust that would indicate a faulty seal. The pulley should turn the shaft (and impeller) smoothly, without noise or sluggish rotation.

The pulley edges should be smooth and undamaged and the locknut should be drawn up tight.

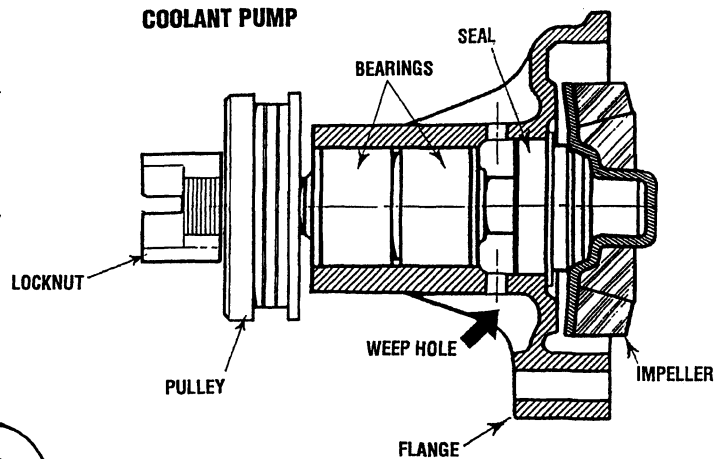

REPAIR

If the pump does not pass inspection, replace the entire pump assembly which includes the pulley.

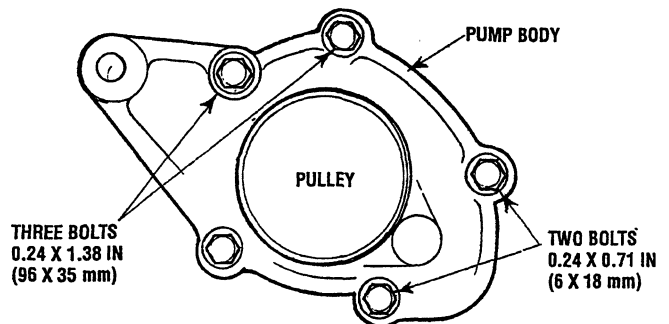

INSTALLATION

When reinstalling the pump use a new gasket. There are five bolts in two sizes that fasten the pump in place, make certain they are positioned properly. See the diagram above. Use sealant when assembling the new gasket.

CIRCULATING PUMP BOLT TORQUE 6 - 7 ft - lbs (8 - 10 Nm)

EXHAUST MANIFOLD / HEAT EXCHANGER

EXHAUST MANIFOLD

The exhaust manifold, which was disassembled from the cylinder head, should be inspected before reassembly.

1. Remove the exhaust elbow from the manifold. Scrape off and discard the old gasket. Inspect the exhaust elbow for corrosion and damage, replace if necessary.
2. If the exhaust elbow passes inspection, remove the high temperature sensor and clean and re-paint the elbow with WESTERBEKE heat resistant enamel.
3. Carefully inspect the exhaust manifold, remove the hose connections noting the location of each for proper alignment at reassembly. Clean the exterior and interior manifold. If the manifold can be reused, repaint with WESTERBEKE heat resistant enamel.

ASSEMBLY

1. If the manifold was removed as an assembly and left intact, it can be replaced on the cylinder head in the reverse order of removal. Install a new gasket.
MANIFOLD MOUNTING BOLTS TORQUE 12 - 17 ft-lb (16 - 23 Nm)
2. Attach the hose connections to the manifold and the exhaust elbow. Once the engine has been re-installed and running, carefully check these assemblies and hose connections for leaks.

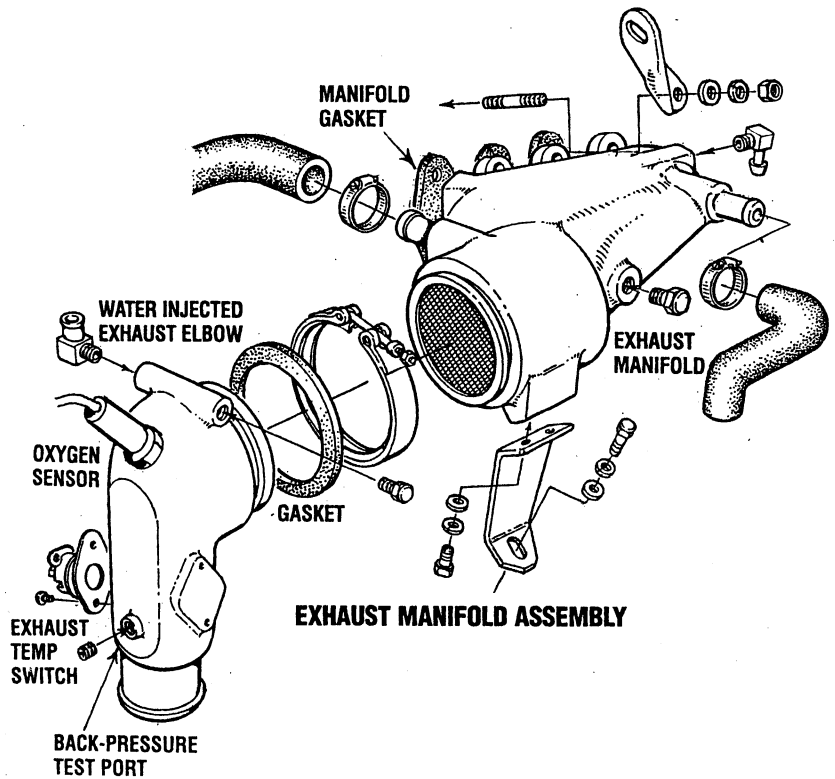

HEAT EXCHANGER

The heat exchanger should be inspected and serviced during an engine overhaul.

1. Disconnect the hoses and remove the hose fittings, petcock, drain plugs and zinc anode. Also, remove the end fittings and gaskets.
2. Inspect the tube (casing) for wear and dents, if at all suspect replace the heat exchanger.
3. Clean out any zinc debris and pressure test the coolant and raw water passages.
4. When reassembling, install new gaskets and O-rings. Apply some lubricant to the new gaskets and to the petcocks and fittings as you install them.
5. Install a new zinc anode.

NOTE: All of the above can be accomplished by sending the heat exchanger to a heat exchanger/radiator service shop. They will also service transmission and engine oil coolers.

6. Repaint the assembled heat exchanger with WESTERBEKE heat resistant spray enamel

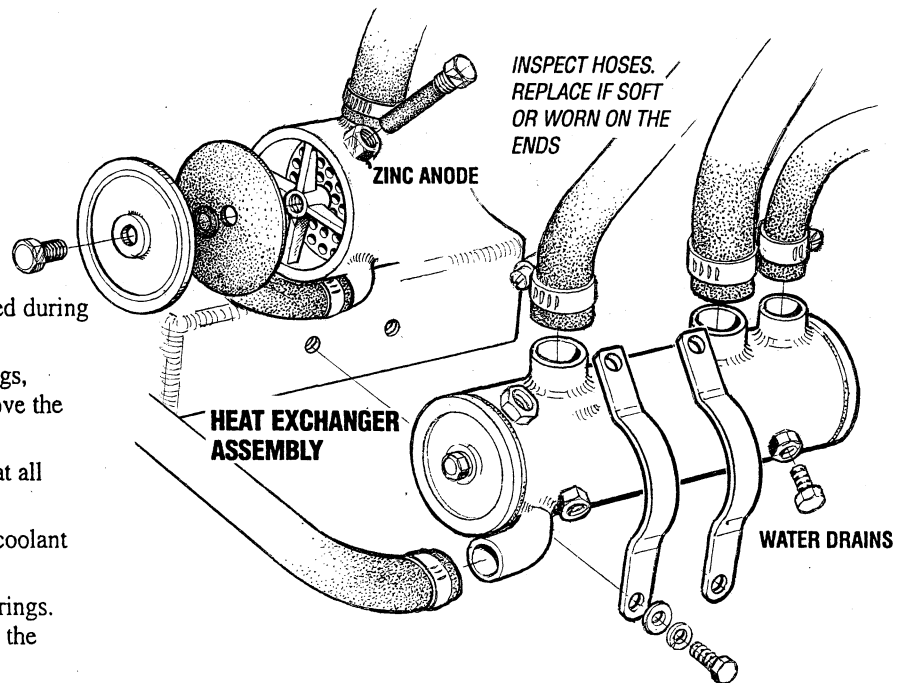

HEAT EXCHANGER ASSEMBLY

Reinstall the heat exchanger. Tighten down the holdown brackets and once the engine is running, check the heat exchanger and hose connections for leaks.

DISTRIBUTOR

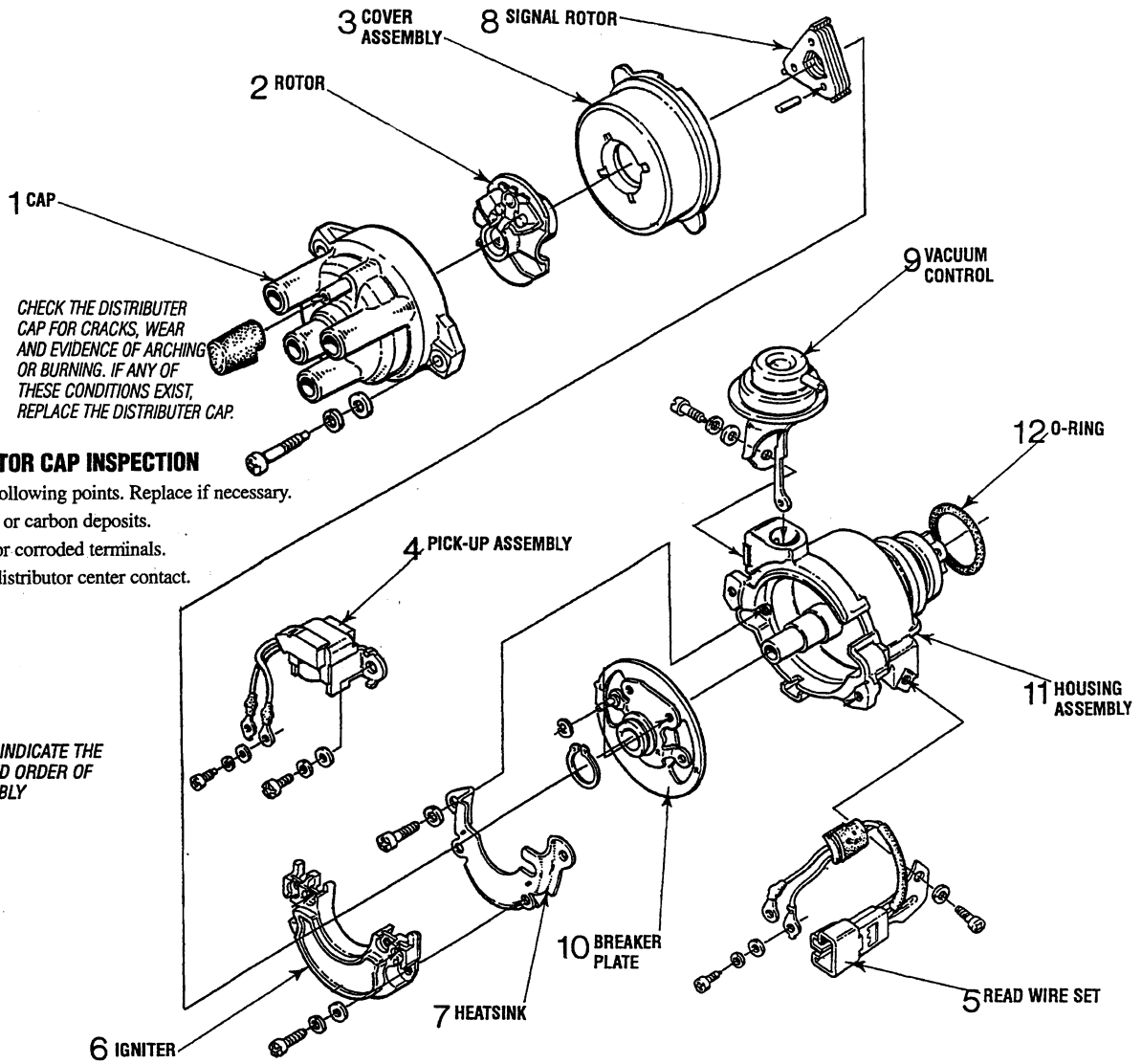

DISTRIBUTOR CAP INSPECTION

Check the following points. Replace if necessary.

1. Cracks or carbon deposits.
2. Burnt or corroded terminals.
3. Worn distributor center contact.

RAW WATER PUMP (PN.042026)

PUMP OVERHAUL

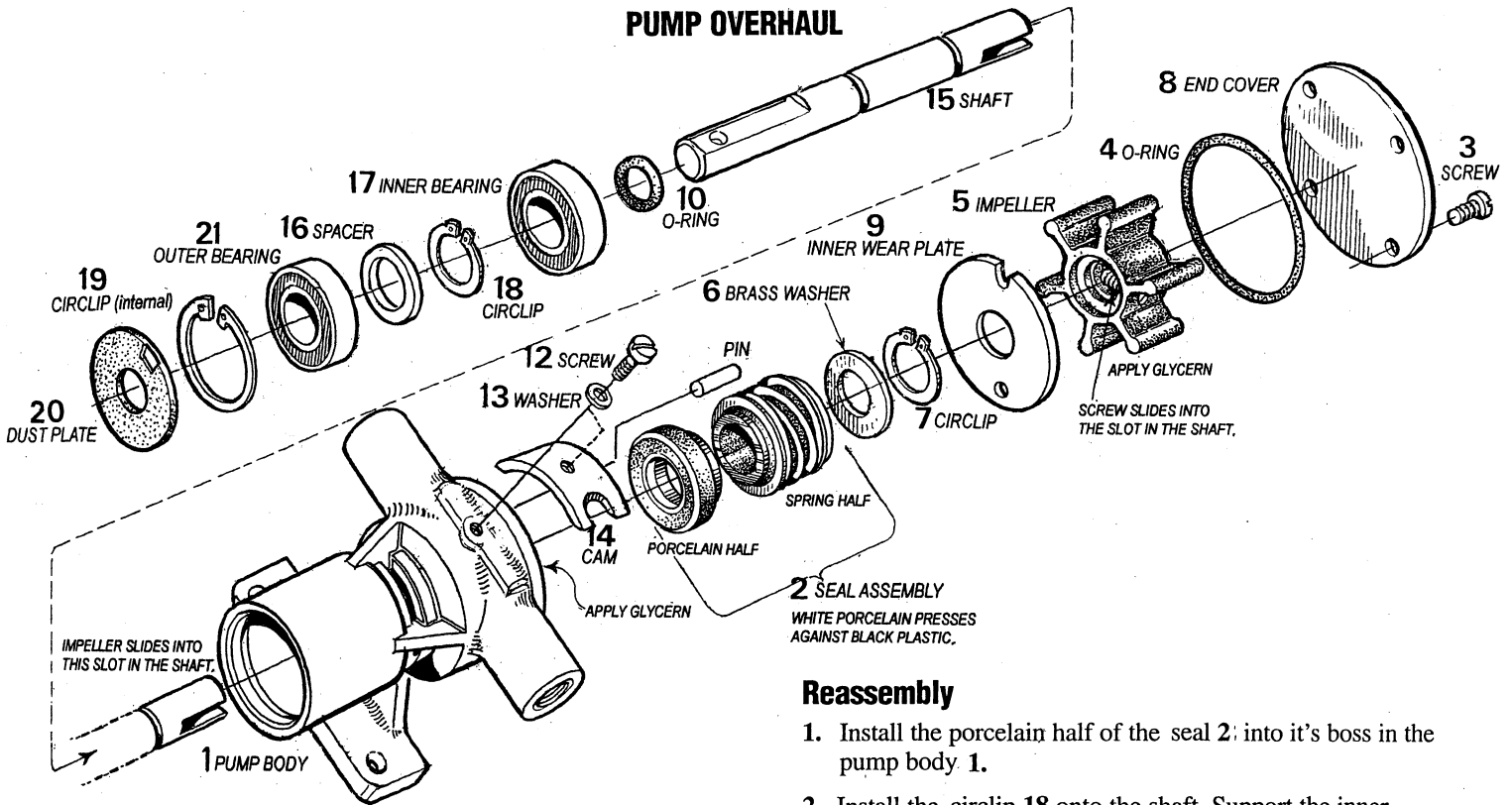

Disassembly

The pump when removed from the engine, will have hose attachment nipples threaded into its inlet and outlet ports along with the drive pulley attached to the shaft of the pump. In most cases the hose nipples can be left in place. Note their positioning. Remove the drive pulley.

1. Remove the four cover plate screws 3 and the end cover 8 and "O" ring 4.
2. Remove the impeller 5 using a pair of pliers, grasp the impeller hub and pull it out of the pump with a twisting motion.
3. Remove the screw 12 and washer 13 that holds the cam in place. Remove the cam 14 and the inner wear plate 9.
4. Remove the brass circlip 7 and the brass holding washer 6 along with the spring half of seal 2.
5. Remove the dust plate 20 along with circlip 19.
6. Support the pump body on an appropriate surface and with a drift, push the shaft 15 with bearing assembly 17, 18, 16 and 17 out of the pump body 1.
7. Remove the "O" ring 10 from the shaft.
8. Support the outer bearing 17 and push the shaft out of the bearing.
9. Remove the spacer 16 and the circlip 18 from the shaft.
10. Support the inner bearing 17 and push the shaft out of the bearing.
11. Using a thin drift, knock the porcelain half of the seal 2 out of its boss in the pump body 1.

Inspection

Inspect all parts. Review the components in the Overhaul Kit #046623 and proceed to re-assemble the pump.

Reassembly

1. Install the porcelain half of the seal 2; into it's boss in the pump body 1.
2. Install the circlip 18 onto the shaft. Support the inner bearing 17 and press the shaft into the bearing until it contacts the circlip.
3. Install the spacer 16 onto the shaft. Support the shaft and push the outer bearing 21 onto the shaft until it contacts the spacer.
4. Apply glycerin to the "O" ring 10 and install it on the shaft about 1/8" away from the inner bearing.
5. Support the pump body on an arbor press and push the shaft and bearing assembly into the pump body until the outer bearing just clears the boss for the circlip 19.
6. Install circlip 19 and push the shaft and bearing assembly so the outer bearing 17 just contacts the circlip 19. Rotate the shaft to ensure no binding.
7. Install the dust plate 20.
8. Apply glycerin to the inner surface of the 2nd half of the seal 2 and with a twisting motion install it over the shaft and slide it down until the plastic surface of the spring seal contacts to porcelain half. Install the spring seal brass washer 6 and secure it in place with the brass circlip 7.
9. Install the wear plate 9, cam 14 and secure the cam with screw 12 and sealing washer 13.
10. Apply glycerin to the surface of the impeller housing, inner surface of the cover plate 8 and sealing "O" ring 4. Fit the "O" ring into its recess in the pump housing.
11. With a twisting motion, install the impeller 5 into the pump so it mates properly with the slot in the shaft 15.
12. Install the drive pulley onto the shaft of the pump. Install the pump onto the engine. Check the pulley/belt alignment. Ensure the pulley is properly secured. Re-attach the raw water hose.

TIGHTENING TORQUE SPECIFICATIONS

Timing Belt	Nm	ft. lbs.	Front Case, Counterbalance Shaft	Nm	ft. lbs.
Flywheel bolt	135-145	98-105	Front case bolts	8-10	6-7
Timing belt cover bolts	10-12	7-9	Oil pump cover bolts	8-10	6-7
Camshaft sprocket bolts	80-100	58-72	Oil pan bolts	10-12	7-9
Oil pump sprocket nuts	50-57	36-41	Oil drain plug	35-45	25-33
Timing tensioner nuts	22-30	16-22	Oil screen bolts	15-22	11-16
Timing belt rear cover bolts	10-12	7-9	Oil pump driven gear bolt	34-40	25-29
Rocker Arms and Rocker Shaft			Rear cover bolts	10-12	7-9
Rocker cover shaft	29-35	21-25	Piston and Connecting Rod		
Camshaft thrust plate bolt	10-12	7-9	Connecting rod cap nut	15 + 90° turn	11 + 90° turn
Rocker arm adjust nut	8-10	6-7	Crankshaft, Bearing		
Cylinder Head, Valve			Oil seal case bolts	10-12	7-9
Cylinder head bolt (cold engine)	60-70	43-51	Bearing cap bolts	50-55	36-40
Spark plug	15.2	11 - 15 lb-ft	Cylinder Block		
Rocket cover	12-13	9-10	Taper plug 1/16 NPT	8-12	6-9
Miscellaneous			Taper plug 1/8 NPT	15-22	11-16
Coolant temperature sender	12-18	9-13	Water drain plug	35-45	25-33
Coolant temperature switch	12-18	9-13	Taper plug 1/4 NPT	35-45	25-33
Generator mounts	34-47	23-34	Oil pressure switch	12-18	9-13
Exhaust manifold	16-23	12-17	Oil pressure sender	12-18	9-13
Thermostat housing	8-11	6-8	Water Pump		
Front Crankshaft bolt	135-145	98-105	Water pump	8-10	6-7

SPECIAL TOOLS - ENGINE

NOTE: *These special tools are available from your local Mitsubishi Automotive Dealer*

CAMSHAFT OIL SEAL INSTALLER
MD 999569

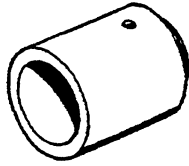

VALVE STEM SEAL INSTALLER
MD 998302

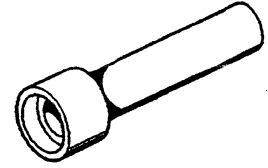

PISTON PIN SETTING BASE
Used to pull-out and press in the piston pin.
MD 999583

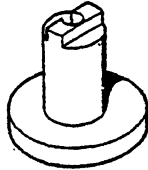

OIL PAN GASKET CUTTER
For removing the oil pan to break the oil pan seal.
MD 998727

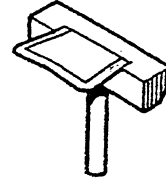

CRANKSHAFT REAR OIL SEAL INSTALLER
MD 998376

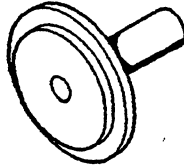

BEARING REMOVER
For pulling out the front and rear bearings (counterbalance shaft).
MD 999593

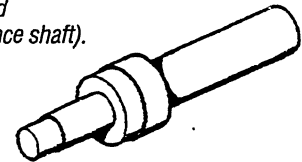

PUSH ROD AND PIN SET GUIDE
Used to pull-out and press in the piston pin.
MD 999584

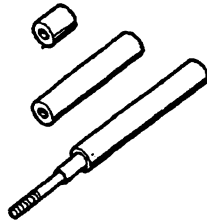

FRONT BEARING INSTALLER
(Counterbalance shaft).
MD 999591

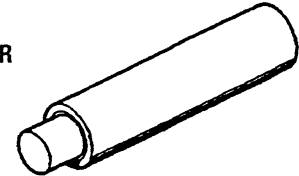

PIN *For supporting the sprocket when the camshaft sprocket is loosened or tightened.*
MD 998715

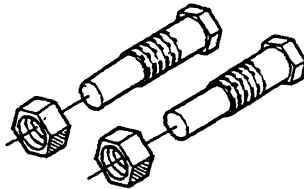

INSTALLER FOR THE REAR OIL SEAL
(Counterbalance shaft).
MD 999592

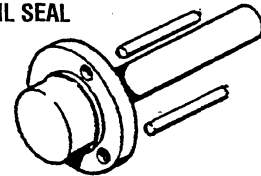

END YOKE HOLDER
For supporting the sprocket when the camshaft sprocket is loosened or tightened.
MD 990767

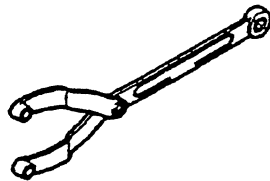

CRANKSHAFT FRONT OIL SEAL INSTALLER
MD 999570

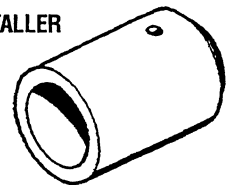

VALVE SPRING COMPRESSOR
MD 999597

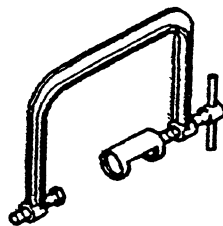

OIL PUMP OIL SEAL INSTALLER

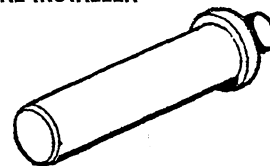

SERVICE DATA / STANDARDS AND LIMITS - MCG ENGINE/GENERATOR

Component	Specified Value / Standard inches(mm)	Repair Limit inches(mm)
FRONT CASE/COUNTERBALANCE SHAFT		
Oil Pump Side Clearance		
Driven Gear.....	0.0024-0.0047 (0.06-0.12)	
Drive Gear.....	0.0027-0.0051 (0.07-0.13)	
Counterbalance Shaft Front Journal Diameter		
.....	0.7869-0.7874 (19.987-20.000)	
Counterbalance Shaft Rear Journal Diameter		
.....	1.7317-1.7322 (43.984-44.000)	
Counterbalance Shaft Front Journal Oil Clearance		
.....	0.0014 - 0.0027 (0.035 - 0.068)	
Counterbalance Shaft Rear Journal Oil Clearance		
.....	0.0014 - 0.0028 (0.035 - 0.071)	

CYLINDER BLOCK		
Cylinder Bore	2.5591-2.5602 (65.00-65.03)	
Out-of-Roundness and Taper of Cylinder Bore	0.0004 (less than 0.01)	
Gasket Surface Flatness	0.0020 (less than 0.05)	0.0039 (0.1)

CYLINDER HEAD		
Flatness of Gasket Surface	0.0019 (Less than 0.05)	0.0079 (0.2)
Overall Height	4.287-4.295 (108.9-109.1)	
Cylinder Head oversize rework dimension of valve seat hole		
Intake 0.3 O.S.....	1.2323 - 1.2333 (31.300 - 3.325)	
Intake 0.6 O.S.....	1.2441 - 1.2451 (31.600 - 31.625)	
Exhaust 0.3 O.S.....	1.1535 - 1.1544 (29.300 - 29.321)	
Exhaust 0.6 O.S.....	1.1653 - 1.1662 (29.600 - 29.621)	
Cylinder Head rework of valve guide hole (both intake and exhaust)		
0.05 O.S.....	0.4744 - 0.4751 (12.050 - 12.068)	
0.25 O.S.....	0.4823 - 0.4830 (12.250 - 12.268)	
0.50 O.S.....	0.4921 - 0.4928 (12.500 - 12.518)	
Intake Valve Seat Angle45°	
Exhaust Valve Seat Angle30°	
Intake Valve Seat Width0.079 (2.0)	0.004 (0.1)
Exhaust Valve Seat Width0.079 (2.0)	0.004 (0.1)
Valve Clearance		
Exhaust.....	0.012 (0.30)	
Intake.....	0.008 (0.20)	
Valve Head Thickness (margin)		
(Intake).....	0.039 (1.0)	0.020 (.5)
(Exhaust).....	0.051 (1.3)	0.031 (.8)
Valve Length		
(Intake).....	3.960 (100.6)	
(Exhaust).....	3.968 (100.8)	
Valve Stem O.D.		
Intake.....	0.2585 - 0.2591 (6.565 - 6.580)	
Exhaust.....	0.2571 - 0.2579 (6.530 - 6.550)	
Stem to Guide Clearance		
Intake.....	0.0008 - 0.0020 (0.02 - 0.05)	0.0039 (0.10)
Exhaust.....	0.0020 - 0.0033 (0.0050 - 0.0085)	0.0059 (0.15)
Valve Guide Length		
(Intake).....	1.73 (44)	
(Exhaust).....	1.949 (49.5)	

Component	Specified Value / Standard inches(mm)	Repair Limit inches(mm)
VALVES		
Valve Guide Service Size	0.05, 0.25, 0.50 oversize	
Valve Seat Width of Seat Contact.....	0.035-0.051 (0.9-1.3)	
Valve Seat Angle.....	30°/44°/65°	
Valve Seat Sink.....	0.008 (0.2)	
Valve Spring Free Length.....	1.823 (46.3)	1.783 (45.3)
Valve Spring Load/Installed Height		
lbs./in (N/mm).....	46/1.48 (210/37.7)	
Squareness.....	less than 2°	4°

TIMING BELT		
.....	47 (12)	

ROCKER ARM		
Camshaft Height		
No. 1 (Intake).....	1.3815 (35.09)	1.3618 (34.59)
No. 2 (Intake).....	1.3807 (35.07)	1.3610 (34.57)
No. 3 (Intake).....	1.3803 (35.06)	1.3606 (34.56)
No. 1 (Exhaust).....	1.3839 (35.15)	1.3642 (34.65)
No. 2 (Exhaust).....	1.3831 (35.13)	1.3634 (34.63)
No. 3 (Exhaust).....	1.3854 (35.190)	1.3657 (34.69)
Camshaft Journal Diameter	1.6118-1.6124(40.940-40.955)	
Bearing Oil Clearance.....	0.0018 - 0.0033 (0.045 - 0.085)	
End Play.....	0.024-0.055 (0.06-14)	118 (.03)
Rocker Shaft Length.....	9.134 (232)	
Rocker Arm Shaft		
Outer Diameter.....	0.6687 - 0.6692 (16.985 - 16.998)	
Clearance.....	0.0005 - 0.0017 (0.012 - 0.043)	0.004 (0.1)

PISTON AND CONNECTING ROD		
Piston Outer Diameter.....	2.5579-2.5591 (64.97-65.00)	
Piston to Cylinder Clearance		
.....	0.0008 - 0.0016 (0.02 - 0.04)	
Piston Ring Groove Width		
No.1.....	0.0480 - 0.0488 (1.22 - 1.24)	
No.2.....	0.0476 - 0.0484 (1.21 - 1.23)	
Oil.....	0.1108 - 0.1116 (2.815 - 2.835)	
Piston Service Size.....	0.25, 0.50, 0.75, 1.00 OS	
Piston Ring End Gap		
No.1.....	0.0059 - 0.0118 (0.15 - 0.30)	0.0315 (0.8)
No.2.....	0.0138 - 0.0197 (0.35 - 0.50)	0.0315 (0.8)
Oil.....	0.008 - 0.028 (0.2 - 0.7)	0.0394 (1.0)
Piston Side Clearance		
No.1.....	0.0012 - 0.0028 (0.03 - 0.07)	0.0047 (0.12)
No.2.....	0.0008 - 0.0024 (0.02 - 0.06)	0.0039 (0.10)
Piston Pin O.D.....	0.6300 - 0.6302 (16.001 - 16.007)	
Piston Pin Press-in Load lbs(N)		
.....	1102 - 3307 (5000 - 15000)	

SERVICE DATA / STANDARDS AND LIMITS - MCG ENGINE/GENERATOR

Component	Specified Value / Standard inches(mm)	Repair Limit inches(mm)
PISTON AND CONNECTING ROD		
Piston Pin Press-in temperatureordinary temperature	
Connecting Rod Center length4.0138 4.0178 (101.95 - 102.05)	
Parallelism between Big End and Small End0.004 (0.05)	
Connecting Rod Twist.....	0.004 (0.1)	
Connecting Rod Big End to Crankshaft Side Clearance0.0039 - 0.0098 (0.10 - 0.25)	0.16 (0.4)

Component	Specified Value / Standard inches(mm)	Repair Limit inches(mm)
CRANKSHAFT, BEARING		
Crankshaft End Play.....	0.0020 - 0.0098 (0.05 - 0.25)	
Crankshaft Journal O.D. ..	1.5740 - 1.5748 (39.98 - 40.0)	
Crankshaft Pin O.D.	1.4165 - 1.4173 (35.98 - 36.00)	
Cylindricity of Journal and PinLess than 0.0002 (0.005)	
Concentricity of Journal and PinLess than 0.0006 (0.015)	
Oil Clearance of Journal0.0008 - 0.0018 (0.021 - 0.045)	0.0039 (0.1)
Oil Clearance of Pin	0.0009 - 0.0020 (0.022 - 0.052)	
Undersize rework dimension of Journal		
0.25 U.S.	1.5644 - 1.5650 (39.735 - 39.750)	
0.50 U.S.	1.5545 - 1.5551 (39.485 - 39.500)	
0.75 U.S.	1.5447 - 1.54539 (39.235 - 39.250)	
Undersize rework of dimension of pin		
0.25 U.S.	1.4069 - 1.4075 (35.735 - 39.750)	
0.50 U.S.	1.3970 - 1.3976 (35.485 - 35.500)	
0.75 U.S.	1.3872 - 1.3878 (35.235 - 35.250)	

ENGINE ADJUSTMENTS

SPEED SENSOR

The speed sensor is mounted on a bracket at the front of the engine adjacent to the front crankshaft pulley. There are three equally spaced protrusions on the pulley that pass the tip of this sensor inducing a voltage pulse that is sent to the ECU and interpreted as engine speed.

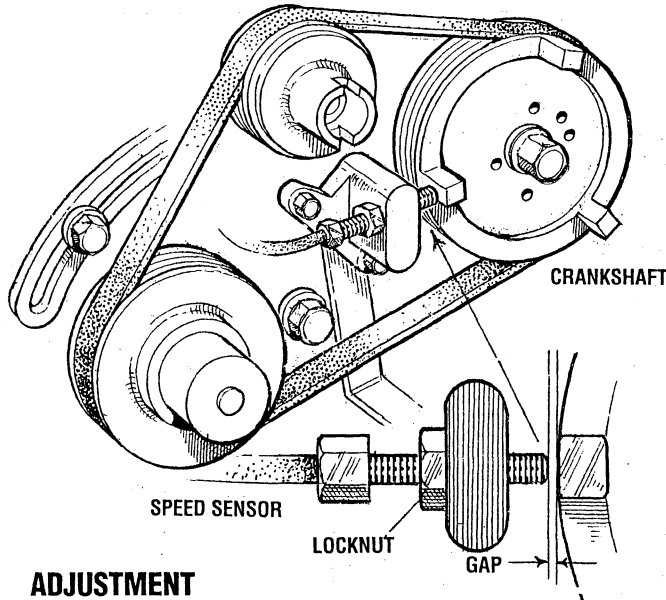

ADJUSTMENT

Position the crankshaft pulley placing one of the protrusions adjacent to the sensor. Thread the sensor in until it touches the surface of the protrusion. Then back it out 2 turns and lock it in position with a locknut.

IGNITION TIMING

1. Attach a timing light to the #1 spark plug and mark the front timing pointer to indicate 15°. Locate the timing mark on the crankshaft pulley and mark it with white chalk or crayon.
2. Start the engine and warm it up to its normal operating temperature. Make sure the generator is operating *without a load on it*.
3. Using the timing light, align the timing mark in the front crankshaft pulley so it is just slightly before the first timing pointer. Do this by loosening and slowly rotating the distributor body. Use the following timing specifications:

TIMING SPECIFICATIONS 15° ± 1.0° BTDC at 1800 RPM
(No-load on generator)

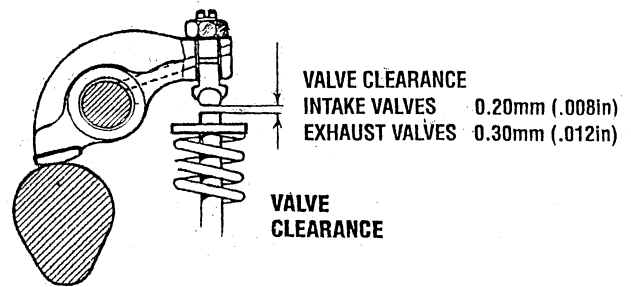
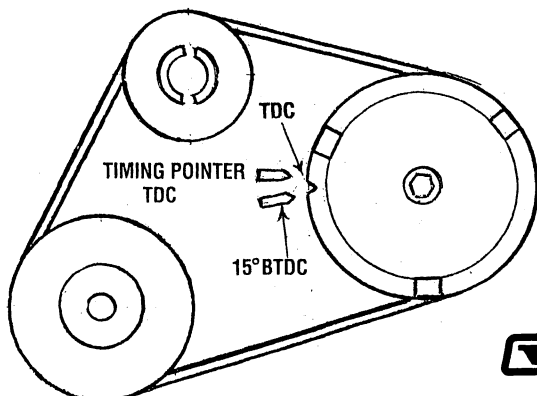

VALVE CLEARANCE ADJUSTMENT

NOTE: Retorque the cylinder head bolts before adjusting the engine's valves. See **TORQUING THE CYLINDER HEAD BOLTS**.

1. Remove the rocker cover and gasket.
2. Remove the spark plugs to observe the piston position in each cylinder head when positioning that piston at TDC.
3. Adjust the intake and exhaust valves in the firing order of the engine (1-3-2) as follows:

Rotate the crankshaft in its normal direction of rotation, observing valve movement and piston location placing No.1 piston at TDC (Top Dead Center) of its compression stroke with the intake and exhaust valves completely closed. Then adjust the intake and exhaust valve clearances.

Rotate the crankshaft 120 degrees to position the piston in cylinder #3 at TDC of its compression stroke and adjust this cylinder's exhaust and intake valves. Rotate the crankshaft another 120 degrees to position the piston in cylinder #2 at TDC of its compression stroke and adjust this cylinder's intake and exhaust valves.

4. Replace the rocker cover and the rocker cover gasket.

Rocker cover torque: 2.9–5.1 lb-ft (0.4–0.7 kg-m).

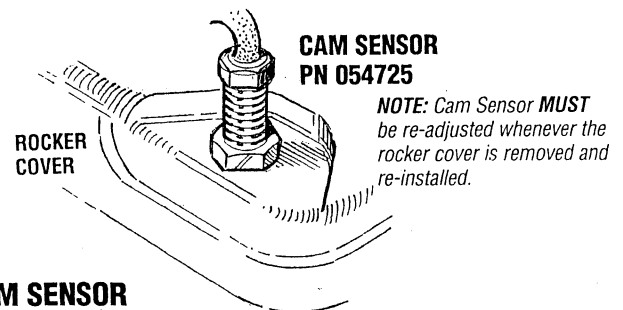

CAM SENSOR

The cam sensor is positioned on the rocker cover over the intake arm for the #1 cylinder. It is a HALL Effect sensor that indicates to the ECU the location of TDC.

To install the sensor, thread the sensor in until it touches the rocker arm with the #1 piston at TDC of its compression stroke. Back it out 1/2 to 1 turn and lock it in position.

ENGINE ADJUSTMENTS

SPARK PLUGS

The spark plugs should be cleaned and re-gapped after the first 50 hour break-in period. Then refer to the Maintenance Schedule in this manual and Specification Section for spark plug gap.

NOTE: It is important to maintain spark plugs in a proper operating condition. They are an important component in the ignition system in lowering carbon monoxide levels.

SPARK PLUG GAP: 0.028 - 0.031in. (0.7 - 0.8mm)
SPARK PLUG TORQUE: 11 - 15 lb.-ft. (1.5 - 2.31 kg-m)

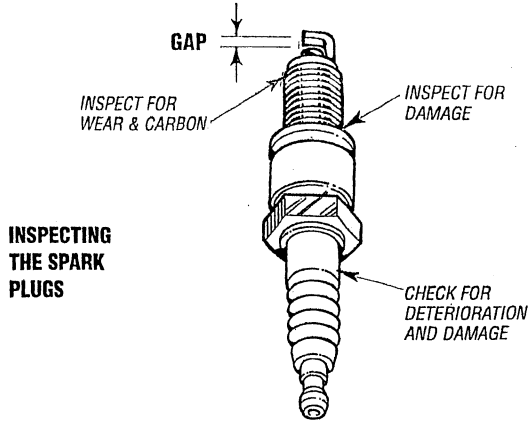

NOTE: Loctite Anti-Seize applied to the threaded portion of the spark plugs will retard corrosion, making future removal of the spark plugs easier.

HIGH TENSION CORDS (IGNITION WIRES)

Check the ignition wires every 500 operating hours as engine compartment heat can deteriorate the wires.

Check the resistance of each wire. Do not pull on the wire because the wire connection inside the cap may become separated or the insulator may be damaged. When removing the wires from the spark plugs, grasp and twist the moulded cap, then pull the cap off the spark plug.

The resistance value is 410 ohm per inch of wire.

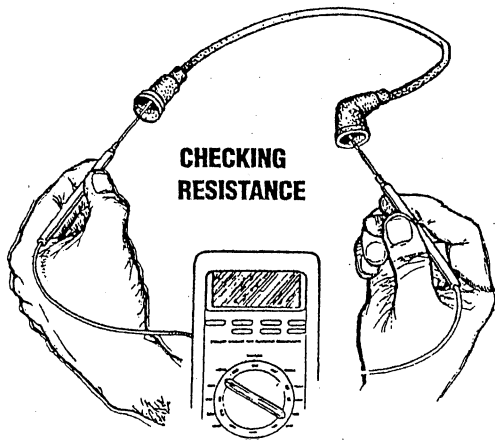

DRIVE BELT ADJUSTMENT

The drive belt must be properly tensioned. Excessive drive belt tension can cause rapid wear of the belt and reduce the service life of the fresh water pump's bearing. A slack belt or the presence of oil on the belt can cause belt slipping, resulting in high operating temperatures.

1. Remove the belt guard.
2. To adjust the raw water pump/fresh water pump drive belt, loosen the two raw water pump mounting bolts. With the belt loose, inspect for wear, cracks, and frayed edges, and replace if necessary.
3. To loosen or tighten the raw water pump/fresh water pump drive belt, slide the raw water pump in or out as required, then retighten its mounting bolts.
4. The drive belt are properly adjusted if it can be deflected no less than 3/8 inch (10mm) and no more than 1/2 inch (12mm) as the belt is depressed with the thumb at the midpoint between the two pulleys on the longest span of the belt.

NOTE: Maintain a 22lb pressure to the belt's outer face for proper belt operation. Spare belts should always be carried on board.

WARNING: Never attempt to check or adjust the drive belt's tension while the engine is in operation.

5. Operate the generator for about 5 minutes, then shut down the generator and re-check the belt tension. Replace the belt guard.

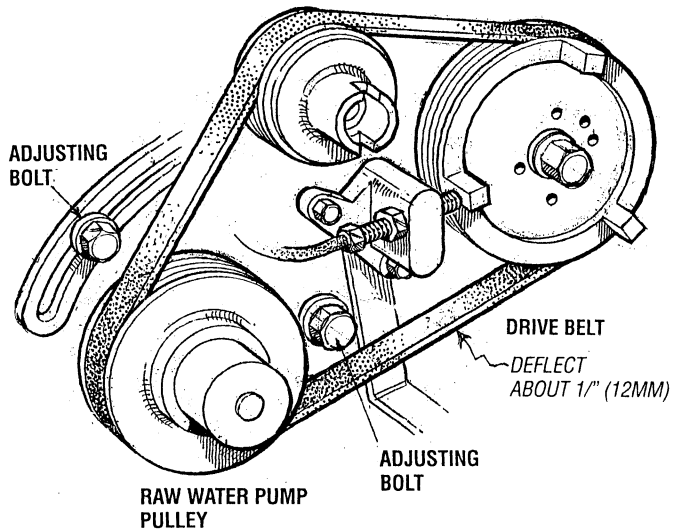

BLEEDING THE FUEL SYSTEM

DESCRIPTION

1. Disconnect the fuel module from the engine wiring harness.
2. Attach your fuel pressure gauge set (Snap On #MT337B, OTC 7211) or equivalent to the Schrader valve on the fuel module. Direct the bleed hose from the pressure gauge into a proper container.
3. Open the bleed valve on the pressure gauge, Depress the **STOP** switch and hold it depressed. This activates the low pressure fuel pump. Observe the fuel flow through the bleed hose and when no air bubbles are seen, close the bleed valve and observe the fuel pressure. Typically about 3-5 psi
4. Remove the pressure gauge from the fuel module and connect it to the Schrader valve on the fuel rail.
5. Re-connect the fuel module to the engine harness.

6. Open the bleed valve on the fuel pressure gauge. Depress the **STOP** switch and hold it depressed. This activates both the low pressure and high pressure fuel pumps. Observe the fuel flow through the bleed hose and when no air bubbles are seen, close the bleed valve and observe the fuel pressure. The pressure should be in the 40 psi range.
7. Remove the pressure gauge set and replace the caps on the two Schrader valves.
8. Insure that all harness connections are secure, operate the generator and check that there are no fuel leaks.

NOTE: The fuel system will need to be bled any time the fuel filters are serviced.

⚠ WARNING: The fuel is under extreme pressure! No smoking and no open flames! Clean up spilled fuel and properly discard of cloths and towels.

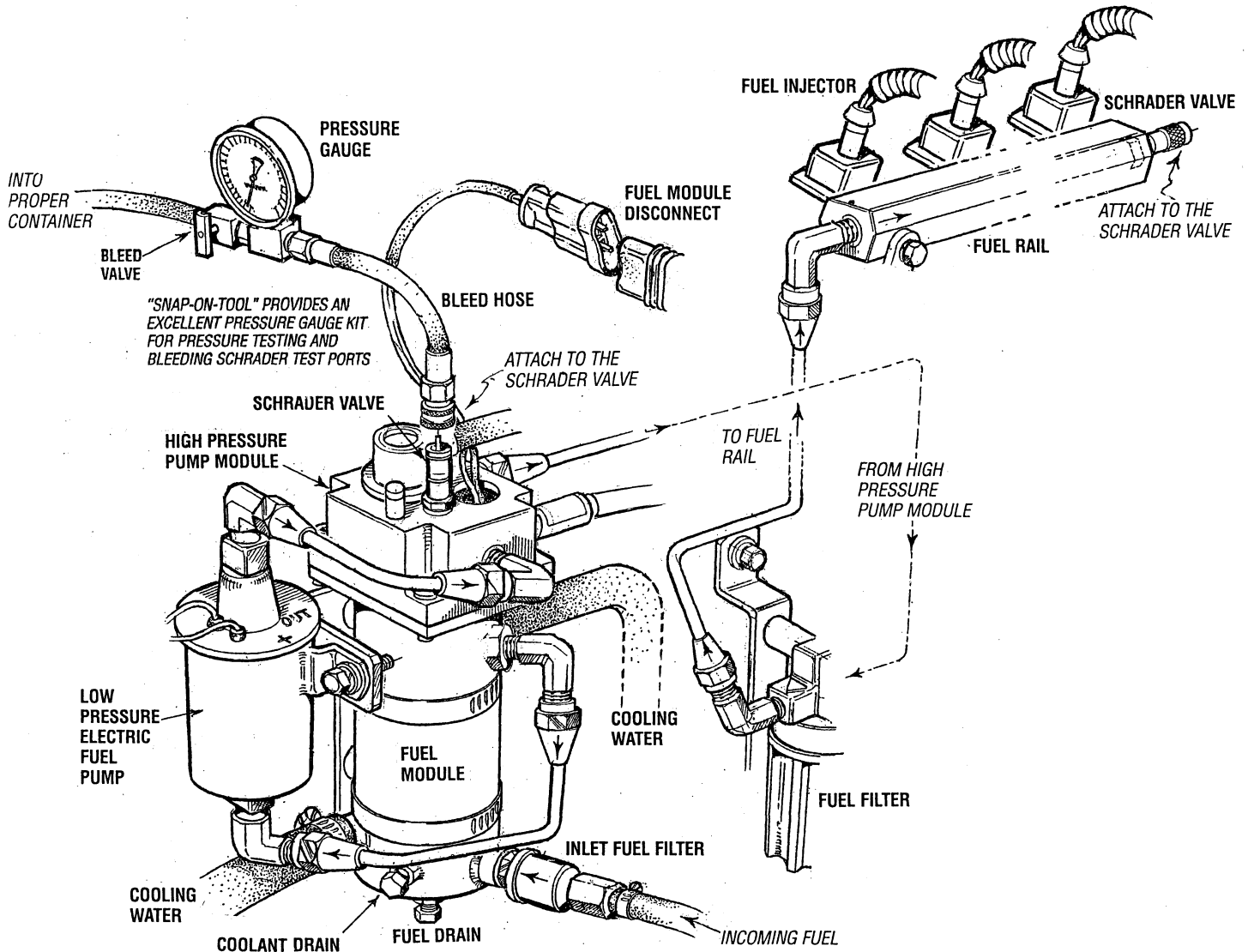

OIL PRESSURE

OIL PRESSURE SENDER

The engine oil pressure is continually monitored by the ECU in the generator control panel when the engine is running. Should the oil pressure fall below a safe operating level, the generator will shut-down and the control panels low oil pressure fault LED will illuminate. Should this occur, **do not** attempt to re-start the generator. Check the oil level and the condition (consistency) of the oil. If there is a loss of oil, inspect the engine for leaks. Inspect the wire connections at the oil gallery (Pressure Sender).

OIL PRESSURE SWITCH

An oil pressure switch is located on the right side of the oil filter mounting bracket. This is a normally open contact switch. It functions with the time relay circuit to ensure DC voltage to the circuit is terminated when the unit shuts down.

TESTING THE OIL PRESSURE SENDER

To test the engines oil pressure, remove the oil pressure switch in the oil gallery and install a mechanical oil pressure test gauge. Start the engine, and with the engine running at its normal RPM, record the pressure.

OIL PRESSURE AT 1800/1500 35-45 PSI OR MORE

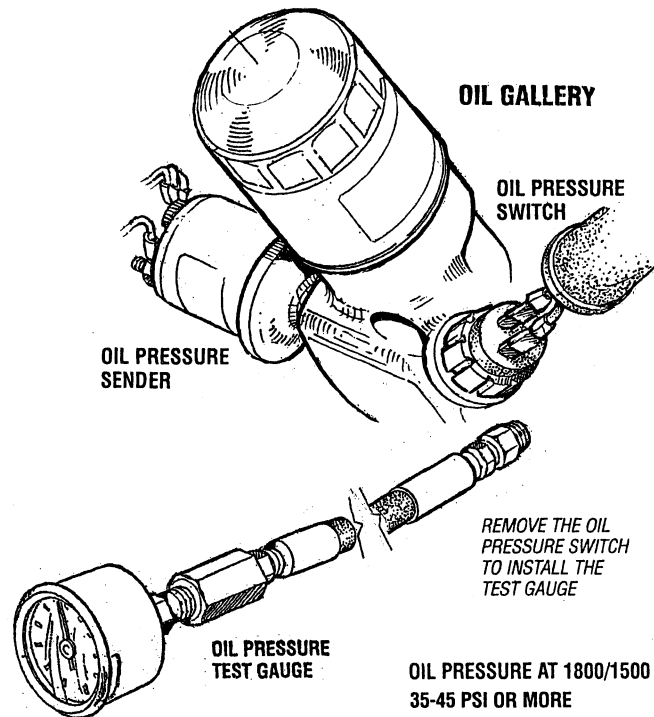

LOW OIL PRESSURE

A legitimate loss of oil pressure can be the result of a faulty oil pressure relief valve or possibly worn bearings in the engine.

MEASURING EXHAUST BACK PRESSURE

Exhaust systems normally produce resistance to the flow of exhaust gases, causing back-pressure. Back-pressure must be kept within a certain limit. **Check the back-pressure before the generator is put back into service.**

To test exhaust pressure, connect either a water column or PSI tube to the test part on the exhaust elbow as shown.

Check the exhaust back-pressure before the generator is put into service. Measure the back-pressure after the engine has reached its normal operating temperature, and at the point where it is about to reach its rated load at either 1500 rpm (for 50Hz applications) or 1800 rpm (for 60Hz applications). Back-pressure should not exceed 1.5 psi (0.11 kg/cm²).

MEASURING EXHAUST BACK PRESSURE

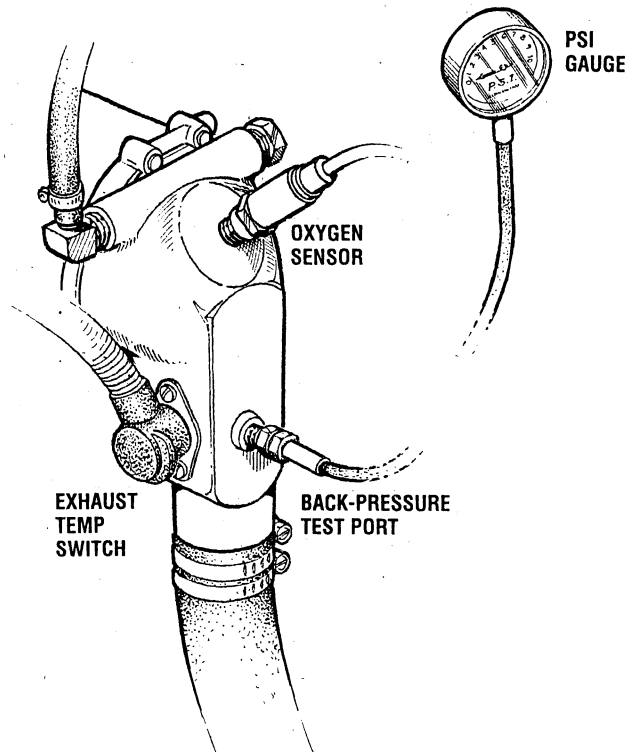

TESTING THE IGNITION COIL

NOTE: An analog type meter must be used when making this test.

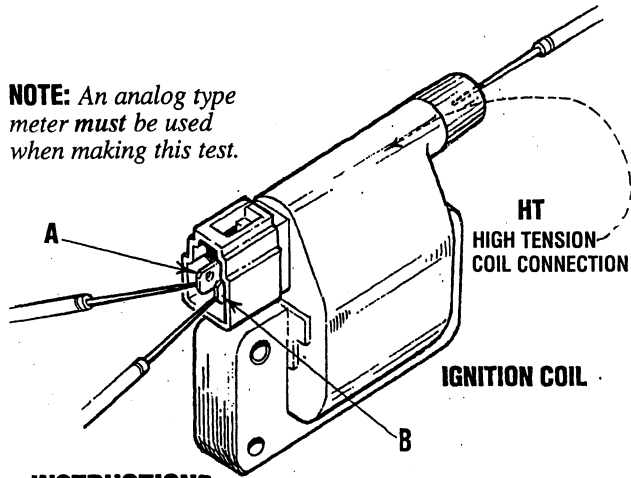

INSTRUCTIONS

Unplug the electrical connections from the coil carefully noting the position of the two electrical connections **A** and **B** as they must be reconnected in the exact same position.

Place the ohmmeter leads on terminals **A** and **B** as shown.

A to B - 1.5 ohm

Place the leads between **A** and the high tension coil **HT** connection.

A to HT - 25.0 - 27.0 kΩ

Place the leads between **B** and the high tension coil **HT** connection.

B to HT - 25.0 - 27.0 kΩ

ADJUSTING THE PICK-UP GAP

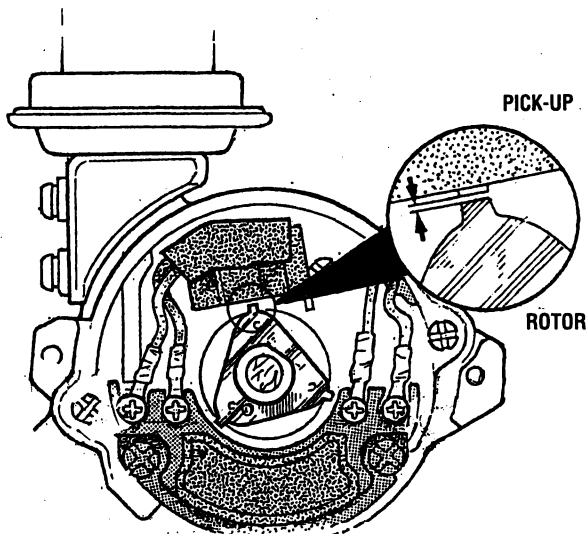

Adjust the point gap of the pick-up assembly between the rotor and the pick-up.

TESTING THE IGNITER

NOTE: An analog type meter must be used when making this test.

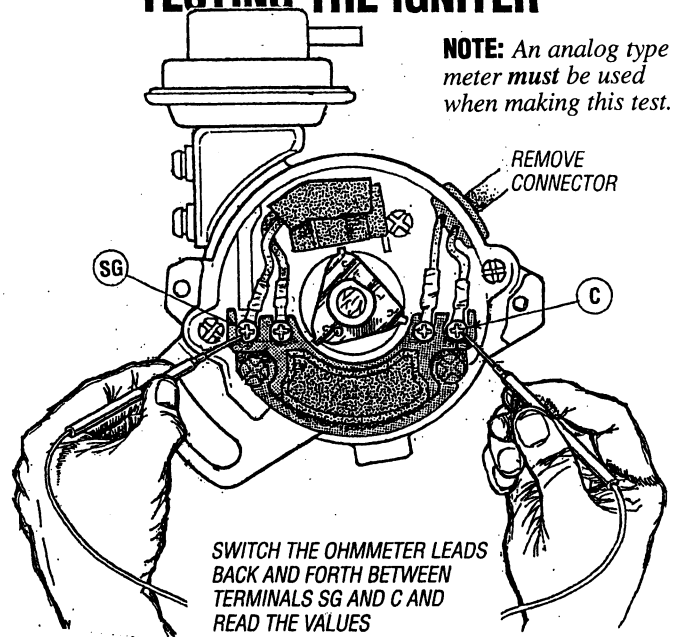

Instructions

Unplug the two connectors at the distribution plug. Take care to note the two separate connections, they must be reconnected in the exact same position. Place your ohmmeter leads on the terminals **SG** and **C** as shown and read the meter. Then reverse the ohmmeter leads and again read the meter.

In one direction, the ohm reading will be 100 ohms or less. In the other direction, there should be no ohm reading. Any value above 100 ohms indicates a faulty igniter. Any ohm value found with the meter connections in either direction, the igniter is faulty.

TESTING THE PICK-UP COIL

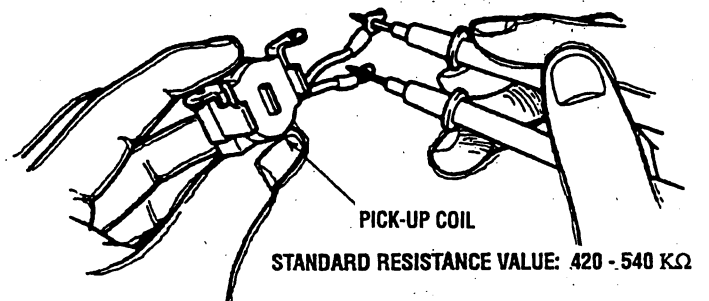

Check that when a screwdriver is passed near the iron core of the pick-up assembly, the needle of the tester deflects.

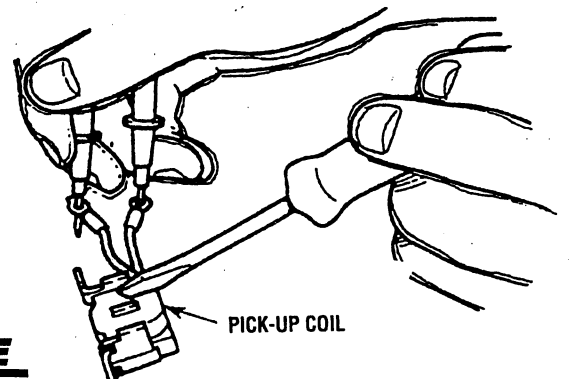

TESTING THE BATTERY CHARGING CIRCUIT

THE CHARGING SYSTEM

Westerbeke's low profile generators are equipped with a battery charge controller that is powered from a separate winding in the generator. The battery charger controller is an encapsulated, solid-state unit that supplies a DC charging voltage to the generator's starting battery while the generator is operating.

Charging Voltage: 13.0 - 13.4 Volts DC
Charging Amperage: 0 - 12 Amps DC

NOTE: The battery charging circuit is totally separate from the AC output of the generator. The generator output affects the circuits output, but not the reverse.

A separate group of stator windings supplies AC voltage to a bridge rectifier which converts the AC current to supply the charging unit. The unit senses the needs of the starting battery and supplies a DC charge when one is needed. If you suspect that the unit is faulty (if the battery's charge is low), check the charging circuit and its components (see *TESTING THE BATTERY CHARGER*). Check all connections for cleanliness and tightness including the ground before replacing the I.C. charger.

NOTE: When the generator is first started, the charger will produce a low charging rate. This charging rate will rise as the generator is operated.

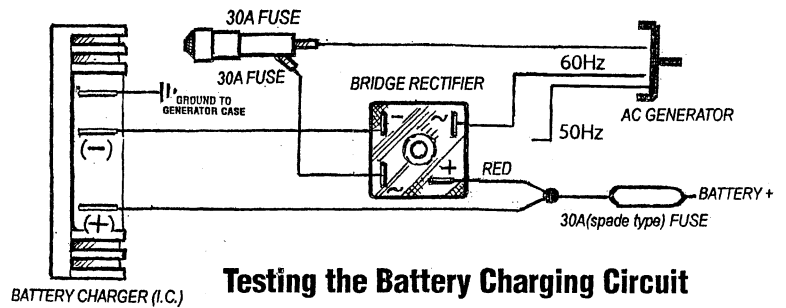

Testing the Battery Charging Circuit

1. Bridge Rectifier

Normal AC voltage running to the rectifier (while the engine is operating at 1800 rpm) is measured across the two AC connections on the bridge rectifier. (As illustrated).

AC voltage running to the bridge rectifier (approximate):

No-load off the generator 16.0 volts AC
Full-load off the generator 17.5 volts AC

Normal DC voltage running out of the rectifier (in volts DC) is measured across the two DC connections of the bridge rectifier; that is + and -.

DC voltage running from the bridge rectifier (approximate):

No-load off the generator 17.0 volts DC
Full-load off the generator 18.5 volts DC

2. AC winding: 0.4 ohm

Lift the two AC wire leads off the bridge rectifier and measure, the resistance between these two leads with an ohmmeter. It should measure 0.14 ohm. No continuity should exist between these two leads and the ground or the main AC stator windings.

Testing the Bridge Rectifier

- Set the meter on Ohms scale.
- Connect the positive (+) lead from the meter to point #4.
- Taking the negative (-) lead, momentarily touch points #1, #2, #3, and #5. There should be no Ohm value registered on the meter.
- Remove the positive (+) lead from point #4 and connect the negative (-) lead to it. Momentarily touch points #1, #2 and #3. The Ohm meter should register an arbitrary ohm value at each point it touches.
- Leaving the negative (-) lead on point #4, touch point #5 with the positive (+) lead. The meter should register no Ohm value.
- Place the positive (+) lead on point #1 and the negative (-) lead on point #3. The meter again should register no Ohm value. Reverse these connections and the meter should register no Ohm value.

If the rectifier fails any of the previous tests B through E, the rectifier is defective. - replace.

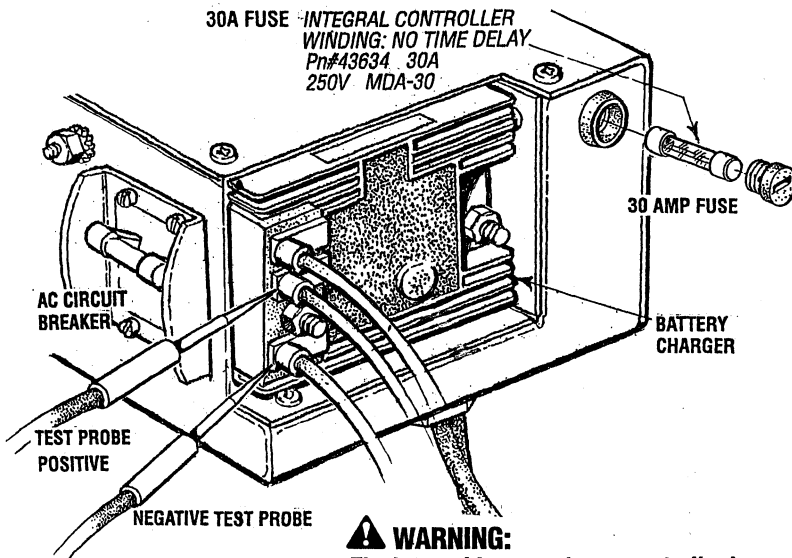

WARNING:
 The integral battery charge controller is factory adjusted and sealed. Tampering with the potentiometer screw voids the charging systems warranty.

Testing the Battery Charger

To test the battery charger, put a multimeter between the positive (+) and negative (-) leads to the battery. It should indicate 13.0V to 13.4V with the engine running. If only the battery voltage is indicated, check that the battery charger terminal connections are tight. With the unit running, test between the (+) and (-) on the battery charger (as illustrated) for 13.0V to 13.4V. If no charge is indicated, replace the charger.

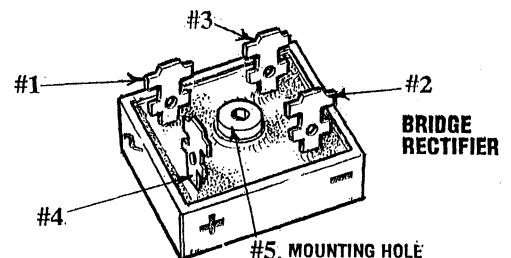

STARTER MOTOR

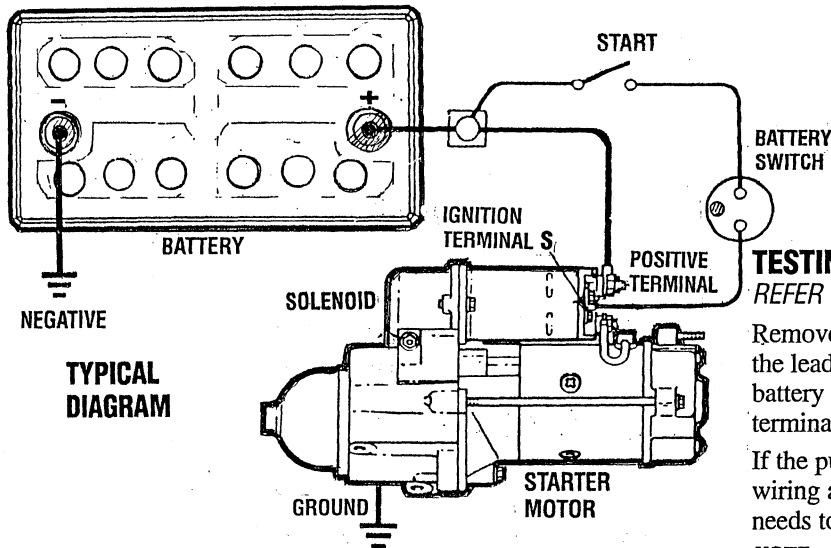

TESTING WITH AN ELECTRICAL JUMPER REFER TO THE ILLUSTRATION BELOW

Remove the **Terminal S** wire from the ignition and attach the lead from the electrical jumper. Leave the + **positive** battery attached and clip the jumper alligator fitting to that terminal. The push button should crank the starter.

If the push button fails to crank the starter and the batteries wiring and wired connections have been checked, the starter needs to be removed for service.

NOTE: This electrical jumper can be fabricated using a standard push button and two connecting wires.

TROUBLESHOOTING/INSPECTION

Prior to testing, make certain the ships batteries are at full charge and that the starting system wiring connections (terminals) are clean and tight. Pay particular attention to the ground wire connections on the engine block.

To check the wiring, try cranking the starter for a few cycles, not more than three crank cycles at a time, then run your hand along the wires and terminals looking for warm spots that indicate resistance. Repair or replace any trouble spots.

Using a multimeter, test the voltage between the positive terminal stud on the start solenoid and the engine block (ground).

If you read 12 volts, the starter is faulty.

If nothing happens at all, the solenoid is not getting current. Check the battery and inspect the wiring connections. It is also possible that the solenoid is defective.

TO REMOVE FOR SERVICE

1. Turn off the DC battery switch.
2. If necessary, remove any components to gain full access to the starter motor.
3. Label and disconnect the wiring from the starter. (Do not allow wires to touch, tape over the terminals).
4. Remove the starter mounting bolts.
5. Remove the starter from the engine. In some cases the starter will have to be turned to a different angle to clear obstructions,

NOTE: WESTERBEKE uses an ignition proof starter approved by the U.S. Coast Guard. If it is necessary to replace the starter, purchase a new starter from a WESTERBEKE dealer/distributor.

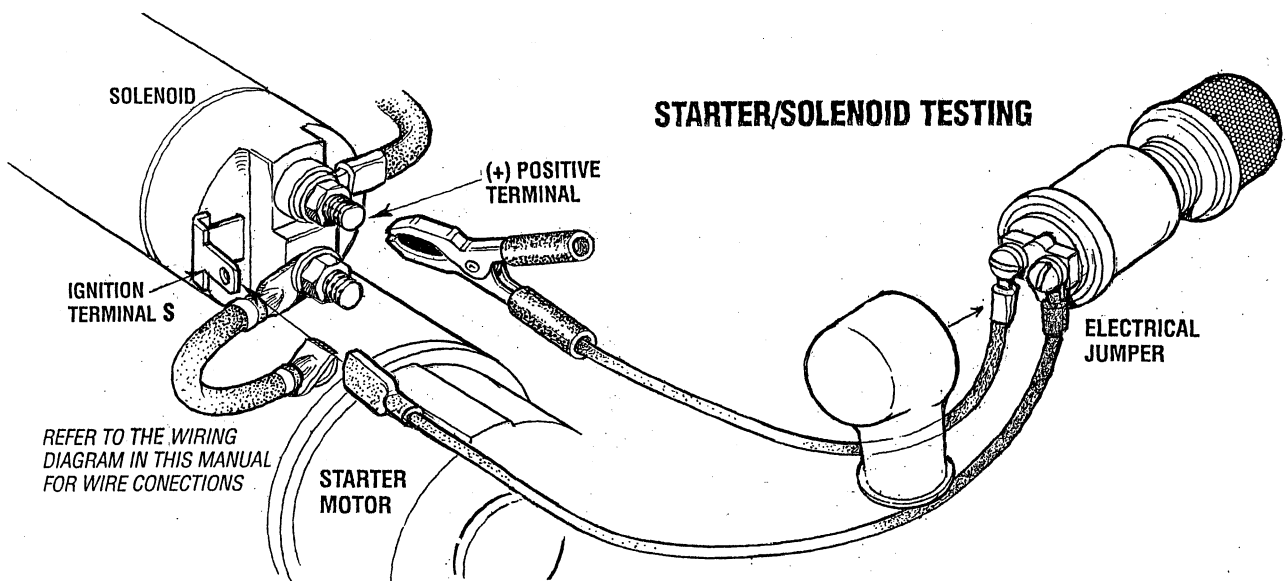

STARTER MOTOR SERVICE

ARMATURE COIL

1. Check the continuity across the commutator and armature coil core with an ohmmeter.
2. If it conducts, replace the armature.
3. Check the continuity across the segments of the commutator with an ohmmeter.
4. If it does not conduct, replace the armature.

RESISTANCE: COMMUTATOR ARMATURE COIL - INFINITY
COMMUTATOR SEGMENT - 0Ω

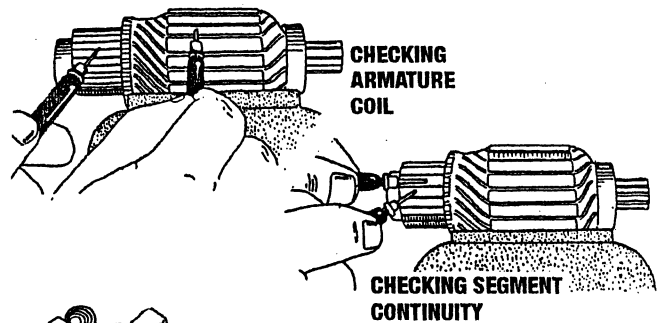

BRUSH HOLDER

1. Check the continuity across the brush holder and the holder support with an ohmmeter.
2. If it conducts, replace the brush holder.
3. If the length is less than the allowable limit, replace the yoke assembly and brush holder.

RESISTANCE: BRUSH HOLDER TO HOLDER SUPPORT - INFINITY

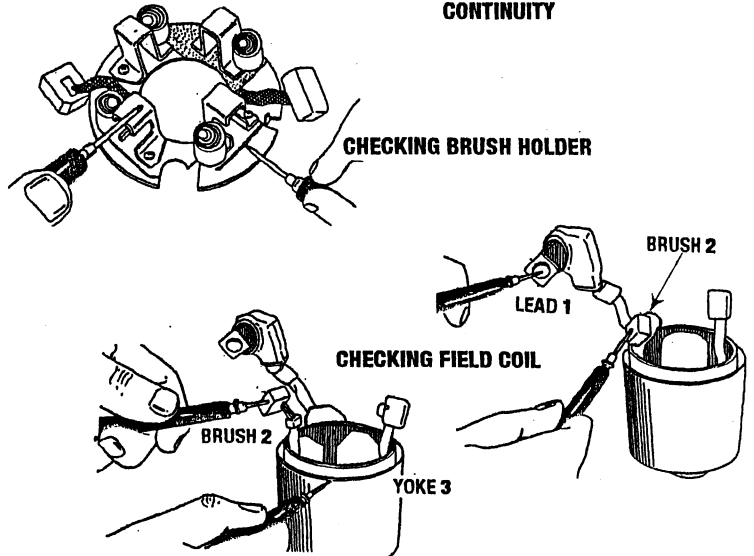

FIELD COIL

1. Check the continuity across the lead (1) and brush (2) with an ohmmeter.
2. If it does not conduct, replace the yoke assembly.
3. Check the continuity across the brush (2) and yoke (3) with an ohmmeter.
4. If it conducts, replace the yoke assembly.

RESISTANCE: LEAD (1) - BRUSH (2) 0Ω / BRUSH (2) - YOKE (3) - INFINITY

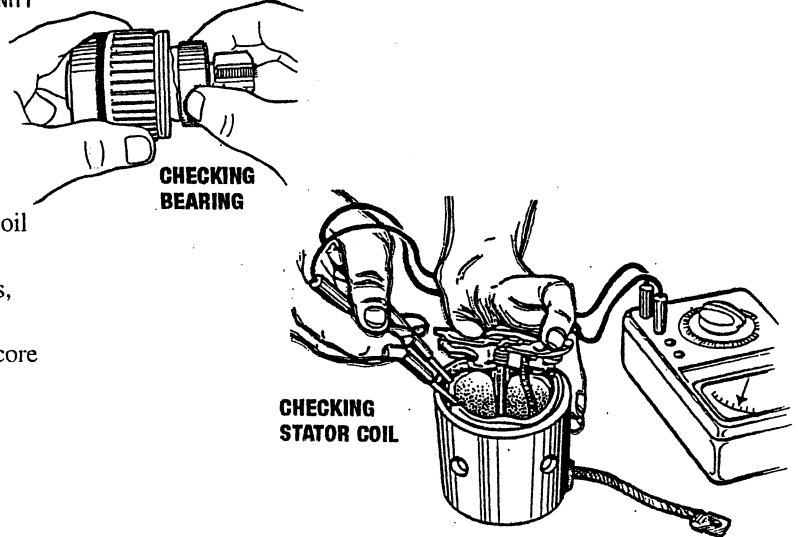

BEARING

1. Check the bearing for smooth rotation.
2. If it does not rotate smoothly, replace it.

STATOR

1. Measure the resistance across each lead of the stator coil with an ohmmeter.
2. If the measurement is not within factory specifications, replace it.
3. Check the continuity across each stator coil lead and core with an ohmmeter.
4. If infinity is not indicated, replace it.

RESISTANCE: LESS THAN 1.0Ω

OVER-RUNNING CLUTCH

1. Inspect the pinion gear for wear or damage. If there is any defect, replace the over-running clutch assembly.
2. Check that the pinion gear turns freely and smoothly in the over-running direction and does not slip in the cranking direction. If the pinion slips or fails to rotate in both directions, replace the over-running clutch assembly.

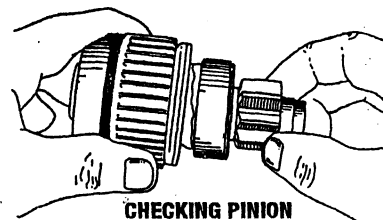

STARTER MOTOR SERVICE

COMMUTATOR AND MICA

1. Check the contact face of the commutator for wear, and grind the commutator with emery paper if it is slightly worn.
2. Measure the commutator O.D. with an outside micrometer at several points.
3. If the minimum O.D. is less than the allowable limit, replace the armature.
4. If the difference of the O.D. exceeds the allowable limit, correct the commutator on a lathe to the factory specifications.
5. Measure the mica undercut.
6. If the undercut is less than the allowable limit, correct it with a saw blade and chamfer the segment edges.

COMMUTATOR O.D. - 32MM (1.2598IN)

LIMIT - 31.4MM (1.2362IN)

MICA UNDERCUT - 0.50 - 0.80MM (0.0197 - 0.0315IN)

LIMIT - 0.20MM (0.0079IN)

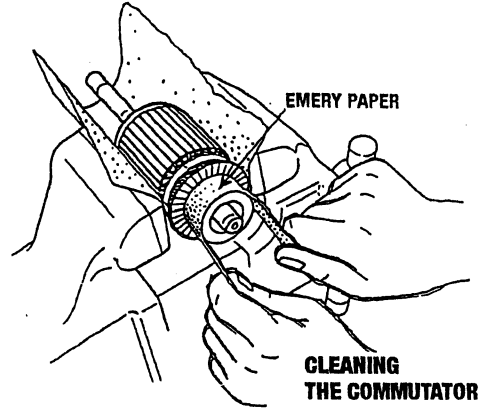
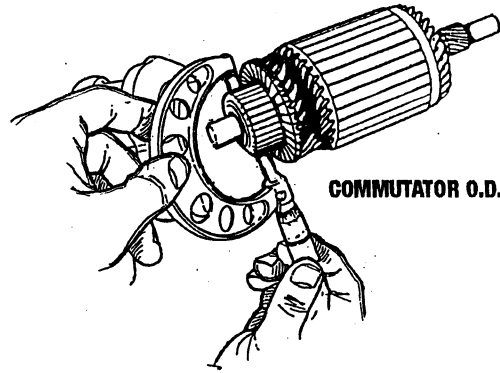
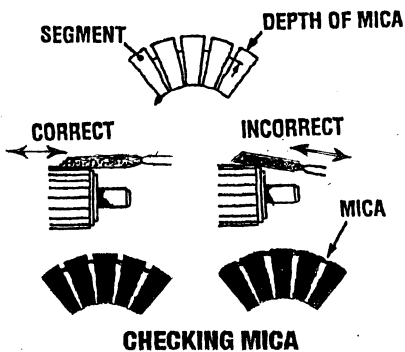

CAUTION: Before installing, thoroughly clean the starter flange and mounting surfaces, remove all old paint and rust. Starter performance largely depends on the quality of the wiring. Use wire of sufficient size and grade between the battery and starter and fully tighten to the terminal.

ELECTRONIC CONTROL UNIT (ECU)

DESCRIPTION

The ECU (Electronic Control Unit) is factory programmed and requires no adjustment. No adjustments in the field can be made to the programming other than engine speed for 50 or 60 hertz operation. The ECU controls starting, engine operation, safety shutdown features and stopping the engine. The 10 pin communications port is used by the factory to input the operating program into the ECU. This connection can be used with available Diagnostic Software Kit #055410 to monitor the operation of the Low CO system and also with the same software to troubleshoot operating faults and change engine operating speed for 50 or 60 hertz operation. The ECU is normally programmed for 60 hertz operation unless specified otherwise. If it is necessary to change the hertz setting of the ECU, the available software has to be used to change this program setting in the ECU. It can not be done any other way.

Setting/Changing Engine Speed

The engine speed can be set for generator operation at either 60Hz (1800 rpm) or 50Hz (1500 rpm). Once the AC voltage output for the generator has been reconfigured as described in the BE Generator section of this manual, proceed as follows:

1. Open the control box on the generator. Shut OFF the DC breaker on the control.
2. Access the opening on the ECU by removing the plug. Connect your laptop (with the software installed) using the communications cable included in the kit to the ECU and turn the laptop ON.

NOTE: The arrow on the communications cable connecting plug for the ECU *must* face the harness connections for the ECU.

3. Turn the DC breaker to the ON position.
4. Using the EC11 software, start communications. Follow the HELP menu instructions for HELP US using the PC Interface. Program the ECU for the hertz that the generator is being converted to.
NOTE: The PC Interface can be left connected to confirm proper rpm during testing. Always stop the generator and turn OFF the DC breaker before disconnecting the communications cable from the ECU.
5. Start the generator and monitor the AC output voltage. Adjust the voltage as needed using the voltage adjustment pod on the voltage regulator.
6. With the speed/hertz verified and the AC output voltage adjusted, close the AC breaker and load test the generator.

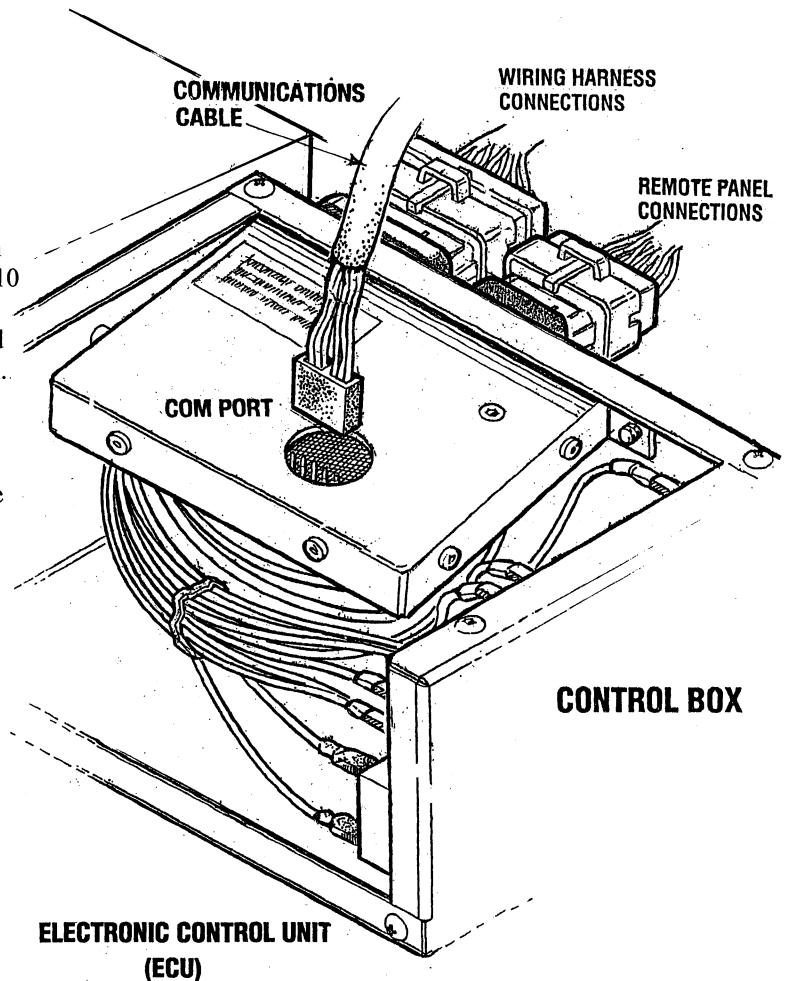

REPLACING THE ECU

Remove the control box cover. Before attempting to remove the ECU, disconnect its power by removing the fuse from the front of the control panel. With the engine harness connections unplugged, unscrew the four side screws and remove the ECU from its holder.

INSTALLING THE NEW ECU

To install the new ECU, reverse the above procedure.

COMPONENT STATIC TESTING

GENERAL

All DC voltage measurements are made to the engine battery negative ground point unless specified otherwise. In making test measurements, make sure that a good ground for the meter is established, preferably the point where the negative battery is connected to the engine. Battery positive voltage is indicated as B+ and should measure no less than 11.5 volts.

AC voltage measurements should be made with a true RMS AC meter to insure accuracy.

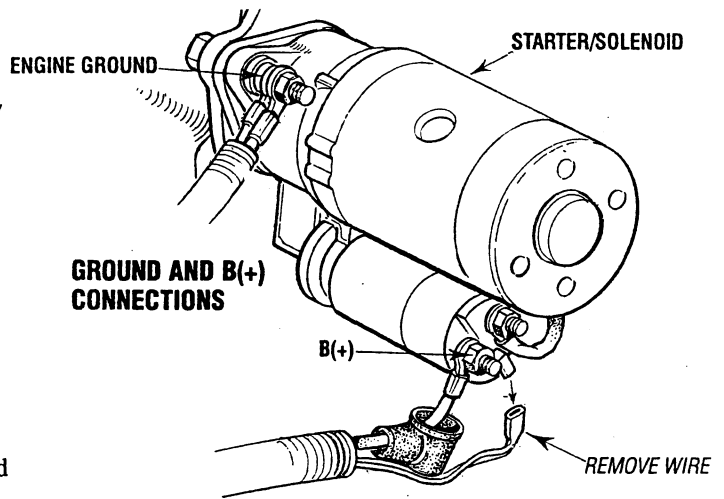

MAP SENSOR

The Manifold Absolute Pressure (MAP) sensor is a solid state pressure transducer which measures the intake manifold pressure (vacuum). It derives its operating power (+5V, Pin 4; Gnd, Pin 1) from the ECU and receives power only when the ECU is in an *on* state. Its output (Pin 3) is measured to ground.

Typical output voltages are as follows:

Map Sensor -- Voltages

	Generators 5.0/6.5Kw
Pin 4 (sig) to Grnd (at rest)	0 VDC
Pin 4 (sig) to Grnd (prime delay in start mode)	4.089 VDC
Pin 4 (sig) to Grnd (running 1800 rpm no AC load)	1.73 VDC (typical)
Pin 3 (+5V) to Grnd (at rest)	0 VDC
Pin 3 (+5V) to Grnd (prime delay in start mode)	4.997 VDC
Pin 3 (+5V) to Grnd (running 1800 rpm no AC load)	5.005 VDC (typical)

Map Sensor -- Resistances

	Generators All Models
Pin 1 (grnd) to Pin 2	1.9Ω
Pin 1 (grnd) to Pin 3	5.9Ω
Pin 1 (grnd) to Pin 4	5.3Ω

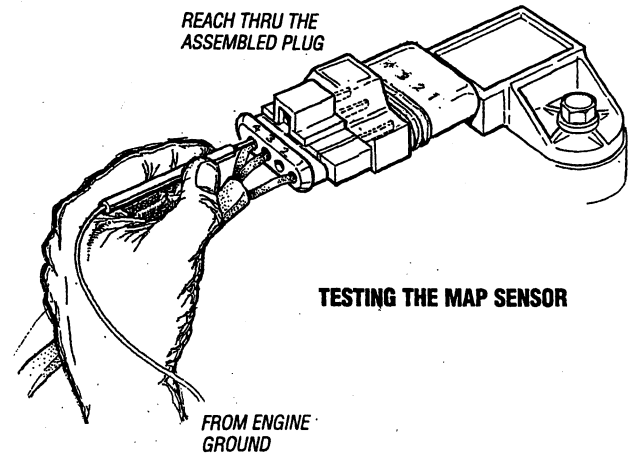

STEPPER MOTOR

STEPPER MOTOR

The throttle plate rotary stepper motor operates on a low DC voltage supplied from the ECU. There are two independent operating coils in the stepper motor. Each coil resistance is typically 2.61 ohms.

A resistance value test only should be performed on the stepper motors two coils. Do not apply 12VDC to these coils as it will damage the coils.

Check the resistance value of each coil between coil #1 (blue and red) and coil #2 (black and green).

There should be no continuity found between any of the coil connectors and the metal case of the stepper body.

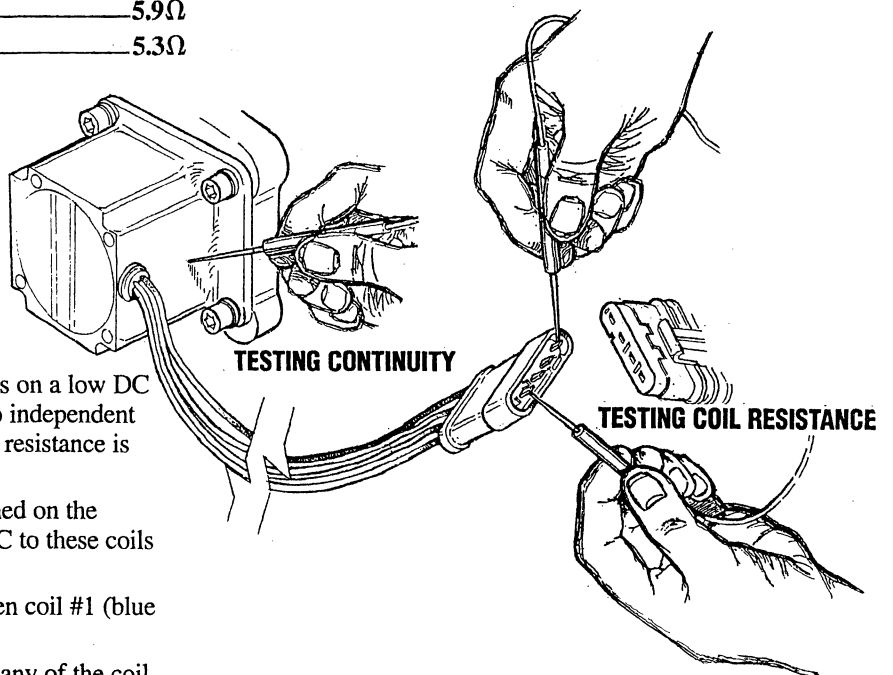

COMPONENT TESTING

TESTING THE OIL PRESSURE SENSOR

The oil pressure sensor sends a DC voltage to the ECU that the ECU interprets as oil pressure. Should this voltage fall below a certain level, the ECU will shut the generator down and illuminate the oil pressure LED.

Test the sensor by checking resistance (at rest):

Ohm Value - 240 - 270Ω

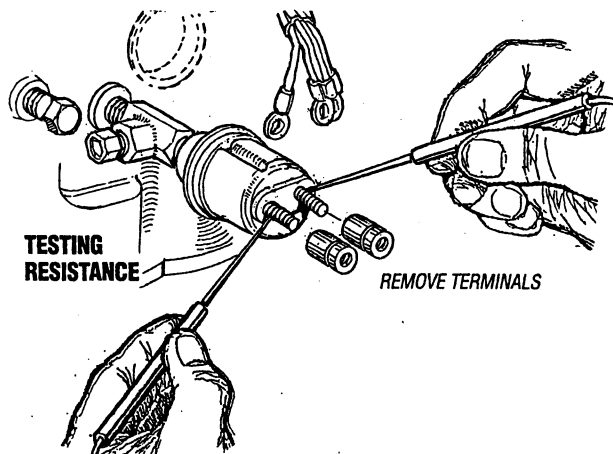

ENGINE DC CIRCUIT BREAKER

The generator's engine DC circuit is protected by a rocker type DC 20 amp breaker mounted on the control box (this also serves as an Emergency Stop Switch). Excessive DC current draw or DC electrical overload anywhere in the instrument panel wiring or engine wiring will cause the breaker to trip to the OFF position. In this event, the DC power to the ECU will be interrupted, stopping the generator. No panel LED will illuminate. Check and repair the source of the problem. After repairing the fault, reset the breaker and restart the generator.

HIGH/LOW RPM SHUTDOWN

The ECU monitors engine speed by the AC voltage produced by the MPU. Should this voltage reach a preset value, the ECU will interpret this as an engine overspeed (2175 rpm approximately) and open the K2 relay, stopping the generator. The panel Overspeed LED will illuminate. Should the MPU produce a low AC voltage that the ECU interprets as an underspeed condition, the ECU will open the K2 relay and stop the generator. The Overspeed LED will then blink.

TESTING THE OXYGEN SENSOR

Wide Band Sensor: Unplug the sensor from the engine harness. Locate the red pin lead and the vacant black pin lead. Measure across these two pins with an ohm meter.

Resistance Value 110.0 - 130.0 OHM (approximately)

No continuity should be found between these two pins and any of the other four.

A sensor not meeting these tests is presumed faulty. Care should be taken when installing a replacement sensor. Do not scratch, damage or handle the sensor end in any way.

TESTING THE EXHAUST TEMPERATURE SWITCH

An exhaust temperature switch is located on the water injected exhaust elbow. Normally closed, this switch will open and the ECU will interpret this as a high exhaust temperature and open the K2 run relay stopping the generator. The exhaust temperature LED on the panel will illuminate.

The switch opens at 260 - 270°F (127 - 132°C). This switch resets (contacts close) at approximately 225°F (107°C).

When testing, continuity should be found (switch is normally closed).

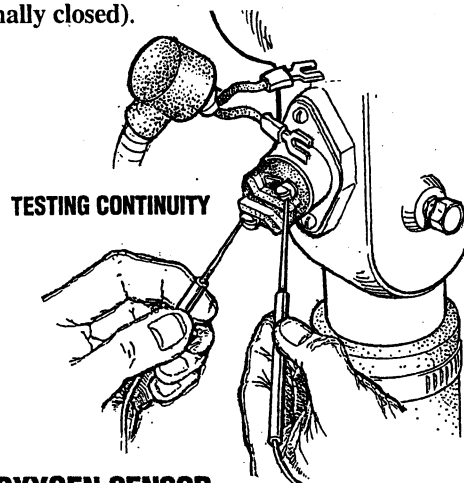

WB OXYGEN SENSOR

The Wide Band O₂ Sensor is installed in the exhaust manifold. It signals the ECU that correct exhaust system discharge is taking place.

COIL VALVE: HEATER ELEMENT
GREY-WHITE 10 OHMS

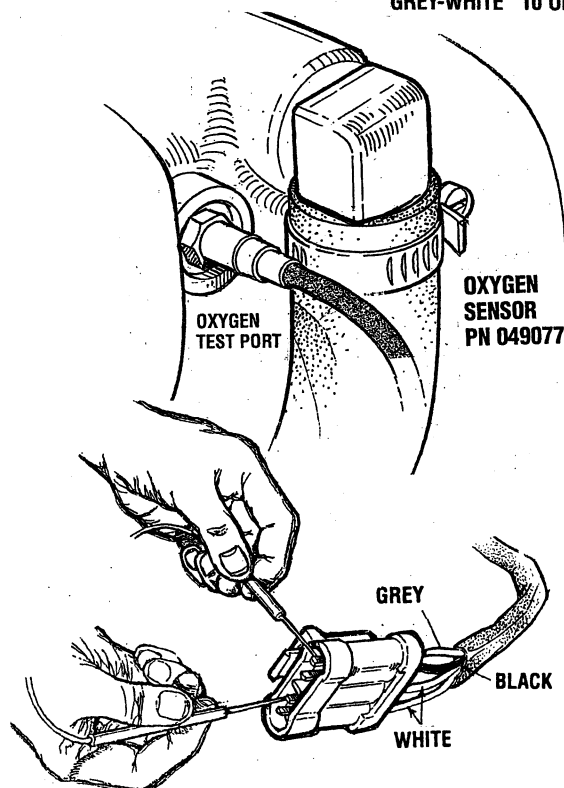

COMPONENT TESTING

TESTING THE MAGNETIC PICK UP COIL

Test the magnetic pick-up AC voltage output while cranking. Voltages are listed below.

Test the magnetic pick-up coil winding in a static mode. Resistance values are shown below. If the AC output voltage is not present or lower than listed and the resistance value of the coil winding is correct, debris may be insulating the MPU tip end. Remove the MPU and examine and clean the tip end of debris.

Coil winding resistance being lower or not present would damage the MPU.

NOTE: Carefully follow the installation instructions provided with the new MPU.

Speed Sensor Test Valves Voltage (while cranking)

5.0, 6.5 Kw MCG - 1.33 VAC

Resistance (at rest) - 950-1000Ω (all models)

NOTE: The AC signal produced by the MPU will be greater the closer the MPU is positioned to the flat of the ring gear tooth and weaker the farther away from the tooth.

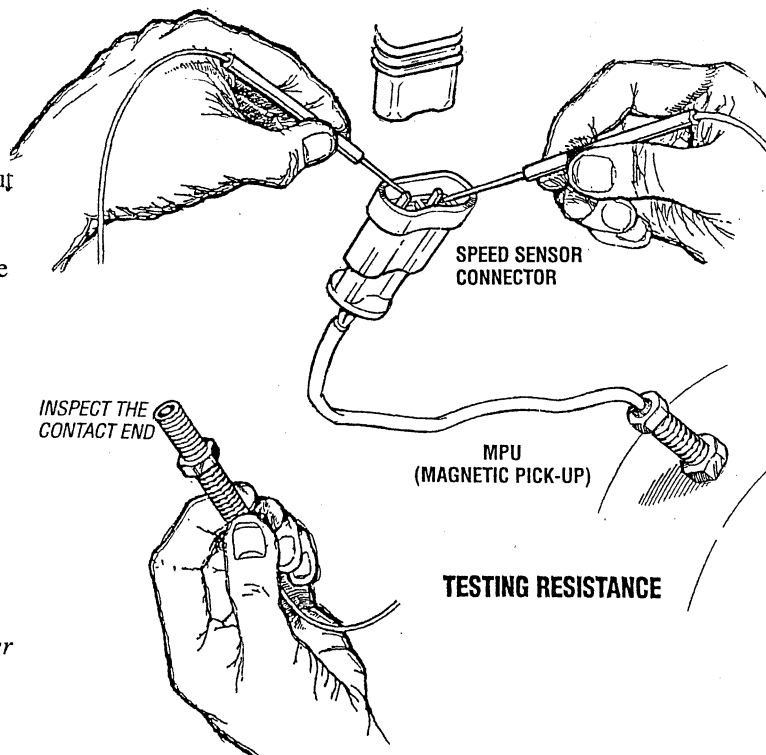

TESTING THE FUEL PRESSURE PUMP

Testing the fuel pumps in a static mode. Check for integrity of the pump winding. Unplug each pump from the engine harness and check the resistance value of the winding.

The lower pressure pump should produce 8-10 psi of pressure when operating measured at the Schrader valve on the fuel cell. The high pressure pump should produce 35-40 psi of pressure when operating measured at the Schrader valve on the throttle body.

Fuel Pump Resistance

High Pressure 8.0 - 12.0 Ohms

Low Pressure 1.5 - 3.0 Ohms

There should be no continuity between the metal case and either terminal of the plug connector.

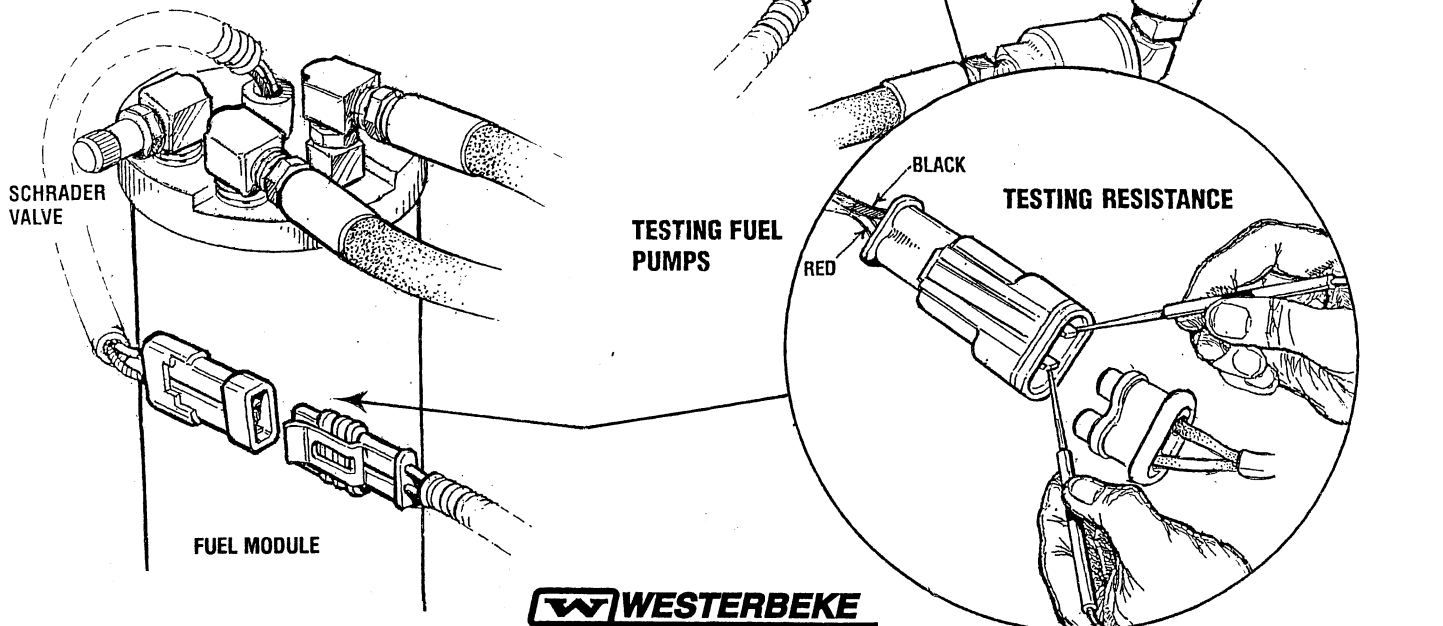

COMPONENT TESTING

AIR AND COOLANT TEMPERATURE SENSORS

These two sensors contain as their sensing elements identical negative temperature coefficient (NTC) thermistors whose internal resistance inversely changes to a change in temperature (i.e., temperature increase, resistance decrease). The thermistors nominal resistance value at 77° F (25° C) is 10,000 ohms. When the ECU is in an *on* state, the thermistors (-) lead is connected to ground, and its (+) lead is connected to the ECU and then through a fixed series 10,000 ohm resistor to the +5V power source. Therefore, the voltage at the thermistors (+) lead should be approximately +2.5 volts at a temperature of 77° F and decreases to a voltage of approximately +.25V at 220° F. The voltage - temperature relationship however, is not linear over this range and therefore it should only serve as an indicator that the thermistor is functioning.

Generally, the thermistor may be assumed to be good if there is a perceptual resistance change for a corresponding temperature over the indicated range, otherwise replace the sensor.

THE AIR TEMPERATURE SENSOR IS LOCATED IN THE LOWER PART OF THE AIR INTAKE HOUSING.

THE COOLANT TEMPERATURE SENSOR IS LOCATED AT THE LOWER REAR OF THE INTAKE MANIFOLD ABOVE AND TO THE LEFT OF THE OIL FILTER.

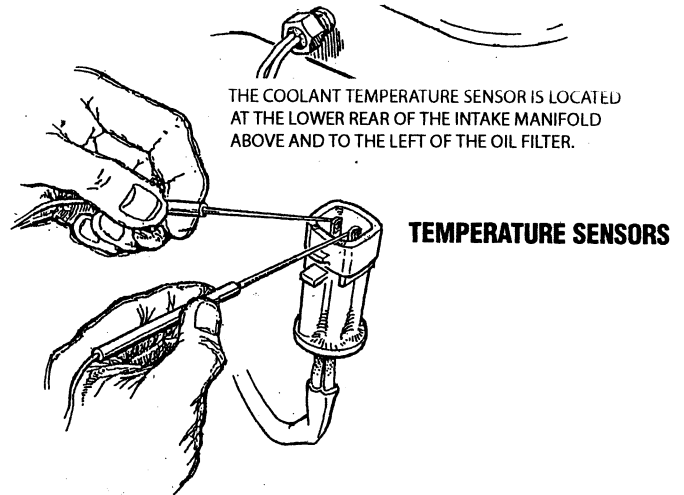

Resistance Values (at room temperature)
 Air Temperature Sensor - 10,000Ω
 Coolant Temperature Sensor - 10,000Ω

FUEL INJECTOR

The fuel injector has no polarity and operates on 12 VDC. The coil resistance is typically in the order of 14 to 16 ohms. The positive wire to the injector is supplied power through the contacts of relay K2, which is off when the engine is not running. To test the injector, disconnect its cable connector and connect a ground wire to one of its input pins. Connect a wire from a point of B+ and repeatedly touch the other input pin. When touched, a low audible click should be perceptible; if not, resistance test the coil. If okay, the injector may be assumed to be functioning electrically. However it could be clogged. If in doubt, replace the injector.

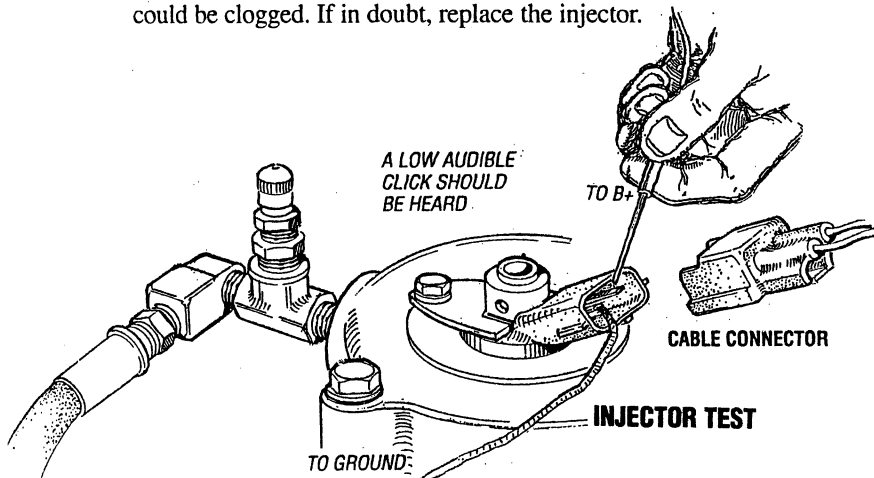

TESTING SYSTEM FUEL PRESSURE

Connect a fuel pressure test gauge to the Schrader valve on the throttle body as shown and run the engine. Pressure readings should indicate 35 - 40 psi.

Pressure gauge kit MT 337B "SNAP-ON-TOOL" is specifically designed for fast accurate testing of fuel pressure for Schrader test ports.

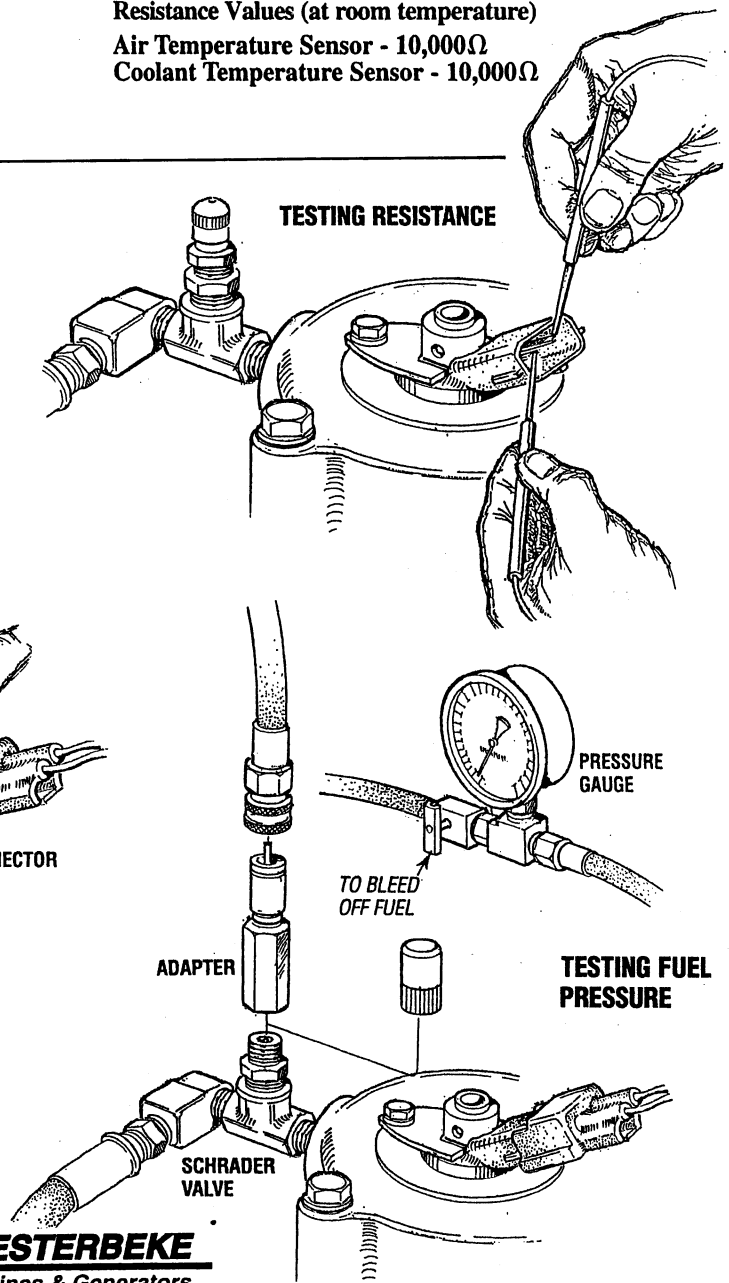

ENGINE TROUBLESHOOTING/SOFTWARE DIAGNOSTICS

PC INTERFACE SOFTWARE

Diagnostic Software Kit #055410 is available for purchase through your Westerbeke Dealer or Distributor.

It contains a PC Interface Software CD for your laptop and a Programmed USB Interconnect Cable to connect between your laptop and the unit's Electronic Control Board (ECU).

**CABLE AND DIAGNOSTIC SOFTWARE KIT
PART #055410 (USB to ECU) SEE BELOW. ***

Your areas distributor can be found on our website:
www.westerbeke.com

This Diagnostic Software is designed to aide the technician in monitoring the engine's operation and the ECU (Electronic Control Unit) functions.

Once downloaded, this software provides IDLE Mode diagnostics, FAILURE Record and Run Time Data Logging to EXCEL.

The Diagnostic Software will run on Windows 98, XP, Vista and Windows 7. These MUST have a minimum of 128 megabytes of RAM (Random Access Memory). The communications cable plugs into a USB port. When using serial to USB adapters, the communication port that the adapter is using MUST be known in order to configure the Diagnostic Software.

The Westerbeke communication cable is unique to this Diagnostic Software and MUST be used or otherwise damage to the ECU will occur if any communications cable is substituted. The Diagnostic Software is designed with multiple screens, tabs and pull down menus to aid the user in the diagnostic process.

The Diagnostic Software is for monitoring the operation of the engine/generator and is also used to change the ECU target frequency between 50Hz and 60Hz.

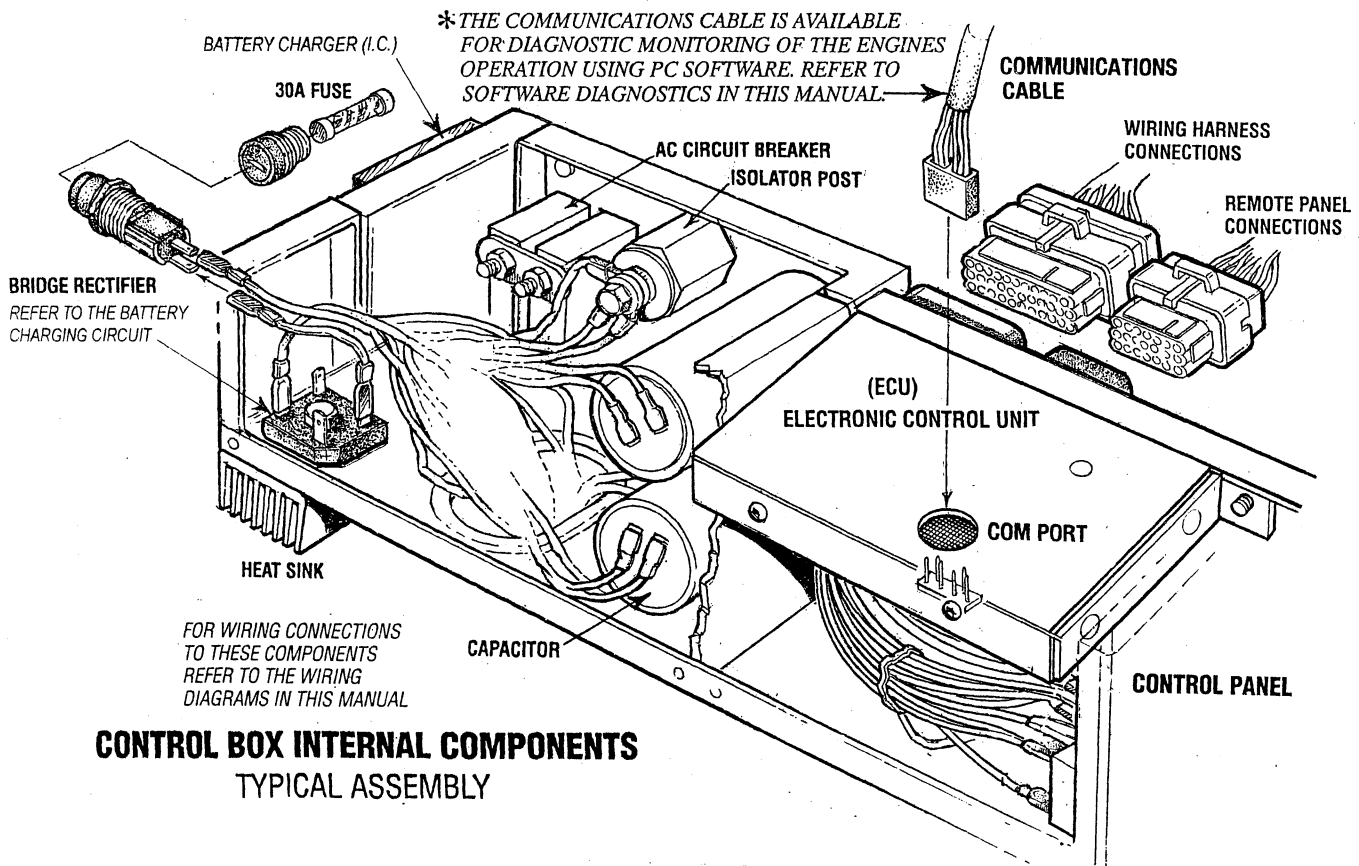
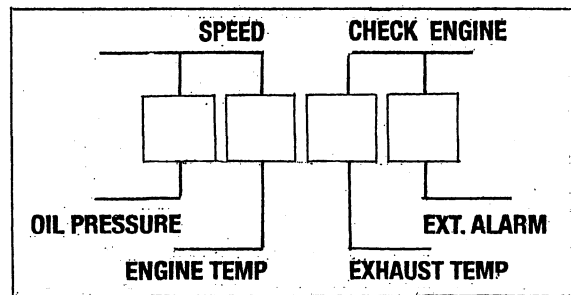

**CONTROL BOX INTERNAL COMPONENTS
TYPICAL ASSEMBLY**

SOFTWARE DIAGNOSTICS

ENGINE WARNINGS IDLE STATE: DC circuit breaker on, generator not running.

In the IDLE state, only *Ambient Air Temperature Low* and *MAP Sensor Possible Fault* are logged. If the fault persists after the generator is started, the CRANK state and RUN state warnings and shutdowns will apply. There are NO shutdowns in the IDLE state, only warnings. Shutdowns can occur in both CRANK and RUN states.

WARNING/DESCRIPTION	PROBLEM	PROBABLE CAUSE
Coolant Temperature Shorted	Short circuit (0 Ohms)	1. Faulty temperature sensor. 2. Pinched or bare wire in harness.
Coolant Temperature Open	Open circuit	1. Faulty ECT sensor. 2. Sensor unplugged. 3. Loose connection or corroded wiring.
Coolant Temperature Low	Reading less than -25°C (-13° F)	1. Excessively cold weather. 2. Faulty temperature sensor.
Coolant Temperature High	Reading more than 95°C (203° F)	1. Faulty temperature sensor. 2. High compartment temperature. 3. Engine heat soak after normal shutdown.
External Alarm	Open circuit	1. External alarm fault (i.e. Fireboy) 2. Loose connection or corroded wiring.
Exhaust Temperature High	Open circuit	1. Faulty exhaust temperature switch. 2. Low coolant flow to exhaust. 3. Loose connection or corroded wiring.
Battery Voltage Low	Less than 12 volts	1. Weak or dead battery. 2. Blown fuse in charging circuit. 3. Faulty regulator or charging circuit. 4. Loose connection or corroded wiring.
Battery Voltage High	More than 15 volts	1. Faulty regulator or charging circuit.
Ambient Air Temperature Shorted	Short circuit (0 Ohms)	1. Faulty temperature sensor. 2. Sensor unplugged. 3. Pinched or bare wire in harness.
Ambient Air Temperature Opened	Open circuit	1. Faulty air temperature sensor. 2. Loose connection or corroded wiring.
Ambient Air Temperature Low	Reading more than -25°C (-13° F)	1. Excessively cold ambient temperature. 2. Faulty air temperature sensor/connection.
Ambient Air Temperature High	Reading more than 63°C (145° F)	1. Excessively hot ambient temperature 2. Bilge venting system faulty or inadequate. 3. Engine heat soak after normal shutdown. 4. Faulty temperature sensor.
Oil Pressure Sensor Shorted	Short circuit (0 ohms)	1. Faulty oil pressure sender. 2. Pinched or shorted wire in harness.
MAP Sensor Possible Fault	MAP reading out of range (<10 kPa or >115 kPa)	1. Faulty MAP sensor. 2. Pinched or shorted wire in harness. 3. Loose connection or corroded wiring.

SOFTWARE DIAGNOSTICS

ENGINE SHUTDOWNS RUN STATE: Engine RUN state is - DC circuit breaker on, generator started and running.

In the RUN state, all shutdowns are logged and a light will be illuminated on the control panel. The generator will be shutdown and the light(s) will stay illuminated until the 12 VDC power to the generator is cycled.

Oil Pressure shutdowns illuminate the **OIL PRESSURE** light.

Engine Coolant Temperature shutdowns illuminate the **ENGINE TEMPERATURE** light.

Exhaust Temperature High shutdown illuminates the **EXHAUST TEMPERATURE** light.

External Alarm shutdown illuminates the **EXTERNAL ALARM** light.

Overspeed and *Underspeed* shutdowns illuminate the pair of **SPEED** lights.

All other shutdowns illuminate the pair of **CHECK ENGINE** lights.

WARNING/DESCRIPTION	PROBLEM	PROBABLE CAUSE
Coolant Temperature Shorted	Short circuit (0 Ohms)	1. Faulty temperature sensor. 2. Pinched or bare wire in harness.
Coolant Temperature Open	Open circuit	1. Faulty ECT sensor. 2. Loose connection or corroded wiring.
Coolant Temperature High	Reading more than 100°C (212° F)	1. Faulty temperature sensor. 2. Coolant or raw water problem/level-flow issue. 3. Engine heat soak after normal shutdown.
Underspeed	Under 1650 rpm for 8 seconds	1. Excessive load on generator. 2. Inspect stepper wiring. 3. Fuel supply insufficient.
Overspeed	Over 2680 rpm for 0.5 seconds Over 2460 rpm for 1.0 seconds Over 2530 rpm for 2.0 seconds Over 2420 rpm for 4.0 seconds	1. Vacuum leak in intake manifold or hoses. 2. Throttle shaft sticking. 3. Inspect stepper wiring.
Crank Sensor Possible Fault	Internal ECU parameter speed signal intermittent.	1. Loose connection or corroded wiring. 2. Sensor needs adjustment. 3. Sensor tip contaminated with metal filings. 4. Crank speed sensor faulty. 5. Speed conditioning module faulty.
Crank Signal Loss	No speed signal to ECU for 3+ seconds.	1. Loose connection or corroded wiring. 2. Sensor tip contaminated with metal filings. 3. Crank speed sensor faulty. 4. Sensor needs adjustment.
Throttle Loss of Home	Internal ECU parameter.	1. Throttle shaft sticking. 2. Weak battery. 3. Inspect stepper wiring.
Oil Pressure Sendor Shorted	Short circuit (0 ohms)	1. Faulty oil pressure sender. 2. Pinched or shorted wire in harness.
Oil Pressure Sendor Open	Open circuit (∞ ohms)	1. Faulty oil pressure sender. 2. Loose connection or corroded wiring.
Oil Pressure Low	Reading less than 8 psi for 5 seconds.	1. Check oil level. 2. Insure proper oil viscosity. 3. Check lubrication system for leaks.

SOFTWARE DIAGNOSTICS

ENGINE SHUTDOWNS RUN STATE: Engine Run State - DC circuit breaker on, generator started and running.

WARNING/DESCRIPTION	PROBLEM	PROBABLE CAUSE
Battery Voltage Low	Less than 11 volts	<ol style="list-style-type: none"> 1. Dead battery. 2. Blown fuse. 3. Faulty regulator or charging circuit. 4. Loose connection or corroded wiring.
Exhaust Temperature High	Open circuit	<ol style="list-style-type: none"> 1. Faulty exhaust temperature switch. 2. Loose connection or corroded wiring. 3. Seawater flow blocked.
External Alarm	Open circuit	<ol style="list-style-type: none"> 1. External alarm fault (ie. Fireboy). 2. Loose connection or corroded wiring.
Wideband O2 Sensor (WBO2) Reading Out of Table	ECU measures $\lambda < .70$ or $\lambda > 2.00$, which is out of the table range	<ol style="list-style-type: none"> 1. Excessively rich or lean combustion. 2. Loose connection or corroded wiring. 3. Oxygen sensor faulty.
Wideband O2 Sensor (WBO2) Failure to Cross Stoich	λ reading not crossing above and below $\lambda = 1.00$ at least once per minute	<ol style="list-style-type: none"> 1. Excessively rich or lean combustion. 2. Excessive fuel caused by faulty ECU or MAP sensor.. 3. Dirty or clogged fuel injector(s). 4. Insufficient fuel supply or pressure.
Wideband O2 Sensor (WBO2) Heater Failure	Heater current out of normal range	<ol style="list-style-type: none"> 1. Loose connection or corroded wiring. 2. Oxygen sensor faulty.
Lambda Set Point Not Achieved	On after start-up	<ol style="list-style-type: none"> 1. Running too rich.
High DC Voltage Charge	16 VDC +	<ol style="list-style-type: none"> 1. Check battery charger.

SOFTWARE DIAGNOSTICS

ENGINE WARNINGS RUN STATE: DC circuit breaker on, generator successfully started and running.

In the RUN state, all warnings are logged and a light will be illuminated on the control panel. The light(s) will go out when the warning condition is no longer present. Warnings will be indicated as follows:

Oil Pressure warnings illuminate the **OIL PRESSURE** light.

Engine Coolant Temperature warnings illuminate the **ENGINE TEMP** light.

Exhaust Temperature High illuminates the **EXHAUST TEMP** light.

External Alarm warning illuminates the **EXT ALARM** light.

Overspeed and *Underspeed* warnings illuminate the pair of **SPEED** lights.

All other warnings illuminate the pair of **CHECK ENGINE** lights.

WARNING/DESCRIPTION	PROBLEM	PROBABLE CAUSE
Coolant Temperature Low	Reading less than -25°C (-13° F)	1. Excessively cold ambient. 2. Faulty temperature sensor.
Coolant Temperature High	Reading more than 95°C (203° F)	1. Faulty temperature sensor. 2. Cooling water issue (raw water or coolant). 3. Thermostat. 4. Engine heat soak after normal shutdown.
Underspeed	60 Hz: Under 1656 rpm for 8+ seconds 50 Hz: Under 1380 rpm for 8+ seconds	1. Excessive load on generator. 2. Air intake blocked. 3. Fuel supply insufficient.
Overspeed	60 Hz: Over 1944 rpm for 4+ seconds 50 Hz: Over 1620 rpm for 4+ seconds	1. Vacuum leak in intake manifold or hoses. 2. Throttle shaft sticking. 3. Stepper unplugged.
Overload	Throttle wide open and RPM 1800 (60Hz) for 1500 (50Hz) for 8+ seconds.	1. Excessive load on generator.
Crank Sensor Possible Fault	Internal ECU parameter.	1. Loose connection or corroded wiring. 2. Needs adjustment. 3. Sensor tip contaminated with metal filings. 4. Faulty sensor.
Oil Pressure Sender Shorted	Short circuit (0 ohms)	1. Faulty oil pressure sender. 2. Pinched or shorted wire in harness.
Oil Pressure Sender Open	Open circuit (∞ ohms)	1. Faulty oil pressure sender. 2. Loose connection or corroded wiring.
Oil Pressure Low	Reading less than 12 psi for 5 seconds.	1. Check oil level. 2. Insure proper oil viscosity. 3. Check lubrication system for leaks.
Battery Voltage Low	Less than 12 volts	1. Dead battery. 2. Blown fuse. 3. Faulty regulator or charging circuit. 4. Loose connection or corroded wiring.
Battery Voltage High	More than 15.5 volts	1. Faulty regulator or charging circuit.
Ambient Air Temperature Shorted	Short circuit (0 Ohms)	1. Faulty temperature sensor. 2. Pinched or bare wire in harness.
Ambient Air Temperature Opened	Open circuit	1. Faulty air temperature sensor. 2. Loose connection or corroded wiring.
Ambient Air Temperature Low	Reading more than -25°C (-13° F)	1. Excessively cold ambient. 2. Faulty air temperature sensor.
Ambient Air Temperature High	Reading more than 95°C (203° F)	1. Excessively hot ambient. 2. Bilge venting system faulty or inadequate. 3. Faulty temperature sensor.

ON-BOARD DIAGNOSTICS 1 PC INTERFACE SOFTWARE

After installing the PC InterfaceDiagnostics Software on your laptop, shut off the 20 amp DC breaker on the generators control box. Attach one end of the Westerbeke communication cable to one of your laptops serial ports. If your laptop does not have a serial port, you must use an adapter that goes from a serial port to a USB. Attach the other end of the communication cable to the 10 pin connection on the ECU. Make sure that the red wire on the communications cable lines up with the pin number 1 on the ECU. Reference the label on the ECU to identify pin number 1. Turn on the 20 amp DC breaker as soon as the communication cable is connected to both the ECU and your laptop.

Open the Interface Software and under *communication* select *comm port*. Select the *comm port* that the cable is connected to. Under *communication* select start comm or ctrl +S. The word *communication* under the menu bar should turn from **RED** to **GREEN** if the communication link is properly achieved. If it does not turn green, check the connections at the PC and the ECU. Make sure that the connector is properly positioned on the ECU and that all the pins are in the connector. Verify the computer Comm Port selected is correct. Make sure the main DC circuit breaker is turned on.

The EC10 interface is divided into four sections. *Engine Conditions, Wideband O2 Sensor Control, Engine Control States and Emissions Records Display.*

ENGINE CONDITIONS

This section monitors the running conditions of the engine.

Coolant Temperature

Coolant temperature is displayed in degrees C and degrees F.

Air Temperature

Air temperature is displayed in degrees C and degrees F.

Engine Oil Pressure

Oil pressure is displayed in BAR and PSI.

Battery Voltage

Battery voltage at the ECU is displayed in Vdc.

Engine Hours

Engine runtime is displayed in hours.

Engine Speed

Engine speed is displayed in RPM.

60Hz operation = 1800 rpm and 50Hz operation = 1500 rpm.

Lambda

ExhaustAir/Fuel mixture. You should see readings going above and below 1.000 continuously as the ECU adjusts the Air/Fuel mxture.

Throttle Position

Indicates the position of the throttle control unit in steps relative to the fully closed position.

Pulse Width

Indicates the fuel injector pulse width.

Manifold Pressure

Indicates the pressure in the intake manifold in kPa.

WIDEBAND O2 SENSOR CONTROL

This section monitors the operating conditions of the wideband oxygen sensor.

WB O2 Sensor States

There are seven wide band sensor states.

1. WB Time Stamp is the initialization state for the wide band lambda sensor.
2. WB OL Delay occurs during the post-crank enrichment period. This is an open loop fueling period. This state is present until the WB02 heater comes up to its operation temperature.
3. WB CL Start Comp is the beginning of closed-loop fueling for the post-startup. The closed loop control targets a rich lambda set point. The lambda set point is a function of engine coolant and this set point leans out as a function of time.
4. WB Warmup is entered only if the engine coolant temperature is not above a certain threshold.
5. WB CL No Fault Checks occurs when the lambda closed loop control is trying to control the fuel delivery to Stoich ($\text{Lambda} = 1.000$) but no checks for emissions faults are performed.
6. WB Closed Loop is closed loop lambda control with a target set point of Stoich and emissions faults checks occurs.
7. WB Open Loop state occurs if an emission malfunction is detected. The closed loop lambda control is disabled.

WB O2 Heater Status

There are three states for the Heater Status. Low Temperature, High Temperature, and Normal Temperature. The Normal Temperature is at 893mV.

WB O2 Crossing Stoich

There are three states for Crossing Stoich. Initialize indicates the initialization period for the sensor. Rich indicates a Lambda lower than 1.000. Lean indicates a Lambda higher than 1.000.

Running Closed Loop PI Control

Indicator will be **RED** when running *Open Loop* and will turn **GREEN** when running *closed loop*.

WB O2 Heater Voltage

This indicator reads the Wideband Heater status in milli-volts. The set point for this function is 893mV.

ON-BOARD DIAGNOSTICS 1 PC INTERFACE SOFTWARE

ENGINE CONTROL STATES

This section monitors the control conditions of the genset.

Emission Conditions

There are four Emission Conditions.

1. **Closed Loop Disabled** - This condition will display if the Wideband O2 Sensor Control has been disabled
2. **Normal Operation** - This condition will display when the engine is running and everything is operating properly.
3. **Sensor Out Of Range** - This condition will display when the lambda is extremely rich (less than 0.8) or very lean (greater than 4.6)..
4. **Not Crossing Stoich** - This condition will display if the engine has been running too Rich or too lean for more than the allotted time period. A perfect Stoich reading in the display is 1.000.

Heater Malfunction - This condition will display if the heater on the Wideband O2 Sensor has failed.. If this condition displays it is probably time to change the Wideband O2 Sensor.

Engine Shutdowns

Along with the PC Interface to display shutdowns, the Genset is equipped with an LCD display to indicate shutdown. Refer to your Owners Manual for a description of the display. When the Genset is operational and everything is operating properly, this box will display Normal Conditions. There are ten Engine Shutdowns that are controlled by the ECU.

1. **Over-Crank Timeout** - This will display if after the start button is pressed and the starter motor is cranking the engine but it does not start the engine in about six seconds.
2. **High Engine Coolant Temperature** - This will display if the temperature of the engine coolant exceeds 95°C.
3. **Overspeed** - This will display if the engine speed exceeds 20% of the desired set speed. (2160 rpm for 60Hz and 1800 rpm for 50Hz).
4. **Underspeed** - This will display if the engine speed falls below 20% of the desired set speed. (1440 rpm for 60Hz and 1200rpm for 50Hz).
5. **Speed Loss** - This will display if there is a loss of speed signal due to a sensor failure or the engine has stopped running due to some other malfunction not covered under the ECU shutdowns. *Sometimes if the Genset runs out of fuel this shutdown or Low Oil Pressure may be displayed.*
6. **High Exhaust Temperature** - This will display if the exhaust elbow overheats due to a lack of raw water discharge. *Check the raw water pump for flow if this failure occurs.*

7. **Low Oil Pressure** - This will display if the oil pressure falls below 8 psi.
8. **Oil Pressure Sensor Shorted** - This will display if there is a short in the oil pressure sensor wire.
9. **External Fault** - This will display if the device connected to the auxiliary fault terminal such as a fire boy device has been triggered.
10. **Low Battery Level on Crank** - This will display if the battery voltage is too low to crank the engine long enough to start.

Engine State

There are five Engine States.

1. **Idle** - This is the state when the engine is turned off..
2. **Crank** - This is the state when the starter motor is engaged and cranking the engine over for starting.
3. **Run** - This is the state when the engine is running.
4. **Shutdown** - This is the state after the stop button has been pressed and the engine is shutting down.
5. **Idle Wait** - This is a short period, approximately 3 seconds, after the stop button has been pressed before the start button can be pressed again. This allows the engine to stop turning before attempting a restart.

Firmware Revision Number

The Firmware Revision Number consists of three parts. The first part is the Part Number, the second part is the Major Revision Number, and the third part is the Major Revision Number.

NOTE: *When requesting service information, please reference the complete Firmware Revision Number.*

Frequency Option

This box displays the position of the Frequency Option Switch on the ECU. On the top of the ECU there is a four position dip switch block. Switch Number 1 is for selecting the desired engine speed. When the switch is in the ON position, the engine will run at 1500 rpm for 50Hz operation. When the switch is in the OFF position, the engine will run at 1800 rpm for 60Hz operation.

NOTE: *To change the speed selection, the engine must be OFF and the Main DC Circuit Breaker on the panel box must be switched OFF. When switching from one frequency to another, there are wiring changes that must be performed before operating the Genset. See you Owner's Manual for further details.*

ON-BOARD DIAGNOSTICS 1 PC INTERFACE SOFTWARE

Start off by collecting data from the time that the engine is started. If you have a genset that has the idle mode, start the PC interface communicating and data logging before you start the engine. If you have an engine that does not have an idle mode, start the PC Interface as soon as possible after the engine is running. Let the engine warm up for about 10 to 15 minutes before trying to apply an AC load. Monitor and record AC volts and amps if possible.

After the engine is warmed up, start applying an AC load by turning on various devices. Let the unit run at each load change for a couple of minutes so that the unit is stable. Monitor and record AC volts and amps if possible at each load site. Continue to as AC load until the unit is at or near full power rating. Power is determined by multiplying the AC voltage times the AC amperage. This will determine if the unit is overloaded or not.

After loading up the genset, begin to reduce the AC load. Let the unit run at each load site for a couple of minutes to stabilize. Continue to reduce the AC load and monitor voltage and amperage until there is no AC load on genset. This will give a technician a baseline of what is going on when the engine is running under a controlled load condition.

Finally, after running the controlled baseline test, this might sound strange, but sometimes the customer might know a particular scenario that will cause a problem for the unit. Sometimes we hear customers say that the unit runs fine for awhile and when my air conditioner shuts off something happens. Try repeating the scenario that the customer mentions. Always start by recording date from the start up for a least a couple of minutes with no load on the generator to get a starting point. Then continue to record data until the problem shows up.

If you have a unit with no idle mode, and the unit shut down under some kind of fault, the date log will automatically stop and save the file. If you have a unit with an idle mode, and the unit was to shut down under some kind of fault, you will have to manually stop the data log to save it. Or in the case of shutting of the DC circuit breaker, this will also cause the data file to stop and save itself.

WHAT TO DO WITH THE DATA

All of the data that is being recorded is also being displayed on the PC Interface in the various boxes. The following information applies whether you are looking at the data file after it has been recorded or watching it live in the PC Interface. The data file can be opened in most spreadsheet software such as Microsoft Excel.

Some of the data that is being collected is pretty much self explanatory and simple to follow. For example, I think that engine temp, air temp, oil pressure, and battery volts would be easy to figure out. Some of the other items may be less familiar.

Speed

Simple enough, this is the speed that the engine is running, the genset is set up to operate at 60 Hz, then the engine needs to run at 1800 rpm (belt driven units may be different). If the unit is set up for 50 Hz operation then the engine speed will be 1500 rpm.

When a genset is governing properly, you should see readings slightly above and below the desired speed. Even a well tuned engine will vary a little. The point is you should see readings above and below the desired speed. If you see speed readings remain more than 20 rpm above or below the desired speed for a prolonged period of time, there could be a problem, especially if this is noticed with no AC load applied.

If the speed is too high with no AC load applied, check the data box labeled Stepper Pos. (steps). The throttle is controlled by a stepper motor. Usually the step count for the engine running with no AC load is typically in the 20-30 steps range. A couple of steps above or below this range does not indicate a problem. However, if the step count is in the single digit numbers or even showing a zero, the problem maybe that the throttle body assembly may be out of calibration or not functioning properly. The stepper motor can only go to a position that it thinks is zero. If the calibration is off, the stepper cannot move the throttle closed enough to slow the engine down. An engine that has this problem will run at the proper speed once some AC load has been added. However, when that load is dropped, the speed will be too high, and in some cases may cause the engine to over-speed and shut down.

If the engine speed is too low with no AC load applied, there is probably a totally different problem. Again, look at the Stepper Position. Is the speed low but steps are high? This would mean that the throttle is being opened to compensate for loss of speed but the speed is not coming up. Check to make sure that the fuel level is full in the fuel system and that the fuel is good and the filters are clear. Bleed the fuel system to remove any air. Check to make sure that the air intake screens are clean. Check to make sure that the spark plugs have not fouled.

If the engine speed is okay when running with no AC load, but once underway with some AC load being applied the speed drops and stays below the desired speed, first check the AC power by multiplying the total AC amperage times the AC volts to get the kilowatts. If this number is higher than what the unit is rated for, then it is overloaded., Shut off some of the devices until the speed returns to normal and check the power again. If there is only a small AC load applied and the speed cannot maintain, follow the same suggestions from the previous paragraph.

ON-BOARD DIAGNOSTICS 1 PC INTERFACE SOFTWARE

Pressure (kPa) - This is the pressure that exists in the intake manifold. At no-load the kPa will be lower than at full load. The wider the throttle plate is open, the closer it gets to atmosphere which is about 100 kPa. Typically a genset running at no-load will see a kPa value around 30, while at full load it would be around 90 kPa. If the kPa is stuck at 70 and never moves then there is a problem with either the MAP sensor or the wiring to the MAP sensor, as 70 is a default value that is in the code.

WB Heater Set-point - This is the set-point in millivolts of the heater temperature in the Wideband O2 Sensor. Currently in all the units that do not have an idle mode, the set point is 893. In other units the set-point will vary but will be displayed in this box.

WB Current Temp - This is the actual value in millivolts of the heater temperature in the Wideband O2 Sensor. If the heater is working properly, you will typically see values stay within 20 millivolts of the set-point. The higher the number is, the colder the heater is. Typically a reading in the 4000 area means that the heater is not working at all. If the value is swinging dramatically above and below the set-point, the sensor is probably failing. The sensor should be replaced.

Lambda - Lambda represents the ratio of the amount present in a combustion chamber compared to the amount that should have been present in order to obtain "perfect" combustion. Thus, when a mixture contains exactly the amount of oxygen required to burn the amount of fuel present the ratio will be one to one and lambda will equal 1,000. If the mixture contains too much oxygen for the amount of fuel (a lean mixture), lambda will be greater than 1,000. If a mixture contains too little oxygen for the amount of fuel (a rich mixture), lambda will be less than 1,000.

Perfect combustion requires an air/fuel ratio of approximately 14.7:1 (by weight) under normal conditions. Thus a lean air/fuel ratio of, say, 16:1 would translate to a lambda value of 1.088. (To calculate, divide 16 by 14.7.) A lambda of .97 would indicate an air/fuel ratio of 14.259:1 (derived by multiplying .97 by 14.7).

In our applications we want to see lambda reading around 1,000. Because of the combustion involved this number will constantly be changing, ideally you should see the value of lambda fluctuating slightly above and below the 1,000 target.

Immediately after a startup it is typical to see a rich readings for lambda. This is part of the startup process and usually takes a couple of minutes for sensors to warm up and take control of the air fuel mixture.

If you see a problem in this area first check the Wideband heater value to make sure that the heater is working. Remember that it takes about three minutes after starting an engine for it to be totally in control. Physically remove the sensor and check it for corrosion and build up of deposits. From the water being injected through the exhaust. Salt water deposited on the sensor will be very damaging. If there is any evidence of build up, replace the sensor.

After checking the sensor and the genset is running too rich, check the air intake screens and spark plugs to make sure they are clean and functioning properly. If the genset is running too lean, check the fuel levels and the quality of the fuel. Water in the gas will cause the genset to run lean.

Lambda PW Trim - Is the fueling trim percentage that the wideband oxygen sensor is contributing. In most cases 15% is the maximum.

Wideband P, I & D Term - These values are the lambda value controlling terms. Their job is to keep the lambda reading at 1,000 by enriching or enleaning the fueling.

Lambda P & I Term - These values are the lambda value controlling terms. Their job is to keep the lambda reading at 1,000 enriching or enleaning the fueling.

NB STT - (Narrowband Short Term Trim) If you genset is equipped with a narrowband oxygen sensor, this will be the value of its contribution. Max contribution is 1%.

Stepper Pos (steps) - The throttle shaft is controlled by a stepper motor. The value displayed is in steps. Zero steps being the closed position. Most units will run at no load in the 20 to 30 steps range. These values will vary from engine to engine.

Pulse Width - Is the fueling duration in milliseconds (ms). The value will be lower at no load than at full load.

Ip Current - Is the electrical value equivalent of the Lambda reading. There is not much to learn from this number.

Main Fuel Comp (%) - Is the fueling compensation that is derived from a value in the fuel table, which is based on the engine rpm and the MAP pressure.

Air Temp and Engine Temp Comp (%) - Is the fueling compensation based on the air temperature and engine temperature. This value can be both positive and negative. This value is added or subtracted from the main fuel compensation value.

Frequency Option - This is the value of the speed selector on the ECU, whether it is 50 or 60 Hz. Some interfaces may not show this column but will display the Frequency Option in the Title area at the top of the data log.

The Generator Frequency - Is a function of engine speed. For most applications, 50 Hz operation is with an engine speed of 1500 rpm, while 60 Hz operation is with an engine speed of 1800 rpm. **Note:** *Belt drive applications will be different, check your owner's manual for engine speed.*

ON-BOARD DIAGNOSTICS 1 PC INTERFACE SOFTWARE

De-rated P Term - This code provided for the P(Proportional) Term, in the speed PID control, to be de-rated right after start-up for a short period of time. This allows the engine to warm up without having an aggressive P value which could cause "hunting" or instability when the engine is cold. On some older units there is also a trim pot on the top of the ECU that can manually de-rate the P value. This will be reflected in this box.

Speed P, I & D Terms - These values reflect the engine speed governing process. These values are constantly changing and it is very hard to get any information from them. The only thing I can say on the subject is that you should see these values constantly changing. If for some reason there are all zeroes in these columns than the engine is probably not running.

EMISSIONS RECORDS DISPLAY

This will display the emissions records stored in the memory of the ECU.

Display Emissions Records

Pressing this button will populate the Emissions Records Display with any emissions records which may have been recorded.

When the engine has been running properly, *Normal Conditions* will appear in the Emissions Records Display. If there are no conditions recorded, the message *There are no emissions records to display* will appear. This should only display when the engine has never been run or the ECU has been replaced.

NOTE: *The engine must be in the Idle state with the main DC circuit breaker ON for this function to work.*

Clear the Display

Pressing this button will clear the Emissions records Display window only. It will not clear the records that are stored in the ECU. This function works with the engine running or in *Idle* mode as long as the main DC circuit breaker is on.

NOTE: *It is very important to use the START/STOP switch to stop the Genset. If the DC circuit breaker is used to shutdown the Genset, no Emissions Record will be logged.*

TO CLOSE THE MONITOR

Click the X in the top right hand corner of the Window or Click File/Exit.

BC GENERATOR SINGLE PHASE

DESCRIPTION

The BC generator is a brushless, self-excited generator which requires only the driving force of the engine to produce an AC output. The stator houses two sets of windings; the main stator windings and the exciter windings. When the generator is started, residual magnetism in the four rotating poles induces a voltage in the stator which then generates an even larger voltage in the exciter windings. This mutual build up of voltage in the four rotating poles and in the exciter windings quickly reaches the saturation point of the capacitor(s) and a regulated energy field is then maintained in the stator. At the same time, this regulated field produces a steady voltage in the stator windings which can then be drawn off the generator's AC terminals to operate AC equipment. The generator is a single-phase, reconnectable 120 volt AC two-wire or 115 volt AC two-wire or 230 volt AC two-wire, at 50 hertz.

The generator's data plate gives the voltage, current and frequency rating of the generator. An AC wiring decal is affixed to the inside of the louvered cover at the generator end. A diagram of the various AC voltage connections is provided on the decal. An Integral Controller (IC) is mounted inside the generator and supplies a continuous DC charge to the generators starting battery when the generator is running.

Bearings: The bearings are sealed type and permanently greased requiring no maintenance during their working life (approx. 30,000 hours).

AC TERMINAL CONNECTIONS

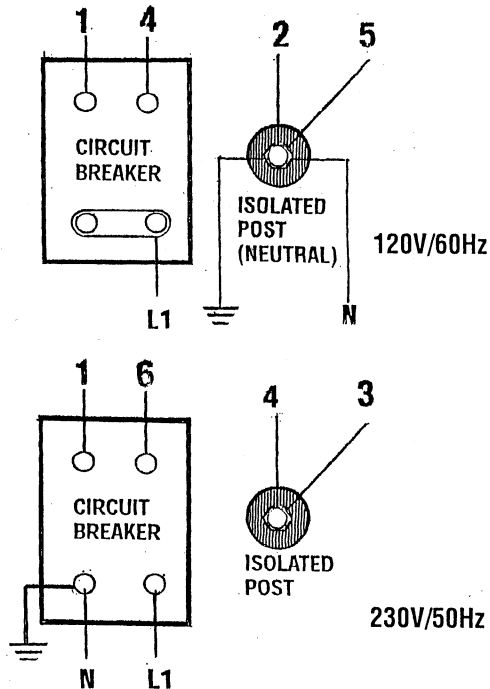

NOTE: Correctly position the case ground wire (white/green) onto the neutral/ground terminal.

MOTOR DATA

The power required to start an electric motor is considerably more than is required to keep it running after it is started. Some motors require much more current to start them than others. Split-phase (AC) motors require more current to start, under similar circumstances, than other types. They are commonly used on easy-starting loads, such as washing machines, or where loads are applied after the motor is started, such as small power tools. Because they require 5 to 7 times as much current to start as to run, their use should be avoided, whenever possible, if the electric motor is to be driven by a small generator. Capacitor and repulsion-induction motors require from 2 to 4 times as much current to start as to run. The current required to start any motor varies with the load connected to it. An electric motor connected to an air compressor, for example, will require more current than a motor to which no load is connected.

In general, the current required to start 115-Volt motors connected to medium starting loads will be approximately as follows:

MOTOR SIZE (HP)	AMPS FOR RUNNING (AMPERES)	AMPS FOR STARTING (AMPERES)
1/6	3.2	6.4 to 22.4*
1/4	4.6	9.2 to 32.2*
1/3	5.2	10.4 to 72.8*
1/2	7.2	14.4 to 29.2*
3/4	10.2	20.4 to 40.8*
1	13	26 to 52

***NOTE:** In the above table the maximum Amps for Starting is more for some small motors than for larger ones. The reason for this is that the hardest starting types (split-phase) are not made in larger sizes.

Because the heavy surge of current needed for starting motors is required for only an instant, the generator will not be damaged if it can bring the motor up to speed in a few seconds. If difficulty is experienced in starting motors, turn off all other electrical loads and, if possible, reduce the load on the electric motor.

Generator Maintenance

Maintaining reasonable cleanliness is important. Connections of terminal boards and rectifiers may become corroded, and insulation surfaces may start conducting if salts, dust, engine exhaust, carbon, etc. are allowed to build up. Clogged ventilation openings may cause excessive heating and reduced life of windings.

In addition to periodic cleaning, the generator should be inspected for tightness of all connections, evidence of overheated terminals and loose or damaged wires.

BC GENERATOR SINGLE PHASE

GENERATOR OUTPUT

To confirm the generator's output capacity, run the generator first with no-load, then at half capacity, and finally load it to full capacity (indicated on the generator's data plate). Voltage and load can be monitored using a portable meter and amp probe. The output should be checked periodically to ensure proper operation of the generator and the appliances it supplies.

ROTATING FIELD/AUXILIARY WINDINGS

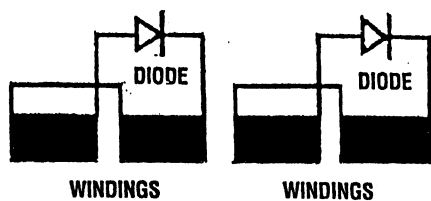

Two sets of windings are found in the rotor assembly. An AC voltage is produced in two groups of windings as the rotor turns at its rated rpm. This AC voltage passes through each of the two diodes mounted on the isolated fixture just before the rotor carrier bearing. The AC sine wave is changed to DC and this DC voltage is passed through the two groups of rotating field windings producing a DC field around these windings. This field affects the AC winding of the two main stator groups inducing an AC voltage in these windings that is available at the AC terminal block connections.

AC CIRCUIT BREAKER

An AC circuit breaker is installed on all single phase generators. This AC circuit breaker will automatically disconnect the generator's output from the vessel's AC load in the event of an amperage overload. In the event of an AC breaker tripping it must be manually reset. **The AC breaker can be manually opened when servicing the generator/engine to ensure no AC voltage is sent to the vessel's distribution panel when operating the unit.**

INTRODUCTION TO TROUBLESHOOTING

The following test procedures can be used to troubleshoot *WESTERBEKE'S 4 POLE DUAL EXCITER CIRCUIT BRUSHLESS GENERATORS*. Due to the simplicity of the generator, troubleshooting is relatively easy.

Field testing and repairing can be accomplished with basic tools and repair parts which should include the following:

A quality multimeter (multitester) capable of reading less than one ohm and with a specific diode testing function.

Basic electrical tools including cutters, soldering iron, wire strapper/crimper, terminal connectors, etc.

Repair parts such as diodes, fuses, bridge rectifier, etc.

PRELIMINARY CHECKING

Before electrical testing, check for proper engine speed/hertz adjustment. Low engine speed will cause low AC voltage output, high engine speed-high AC output.

Refer to *WESTERBEKE'S* operators manual or service manual for engine speed/hertz adjustment or for other possible engine related problems.

Before testing, get a clear explanation of the problem that exists, be certain it relates to generator components.

BC GENERATOR COMPONENTS

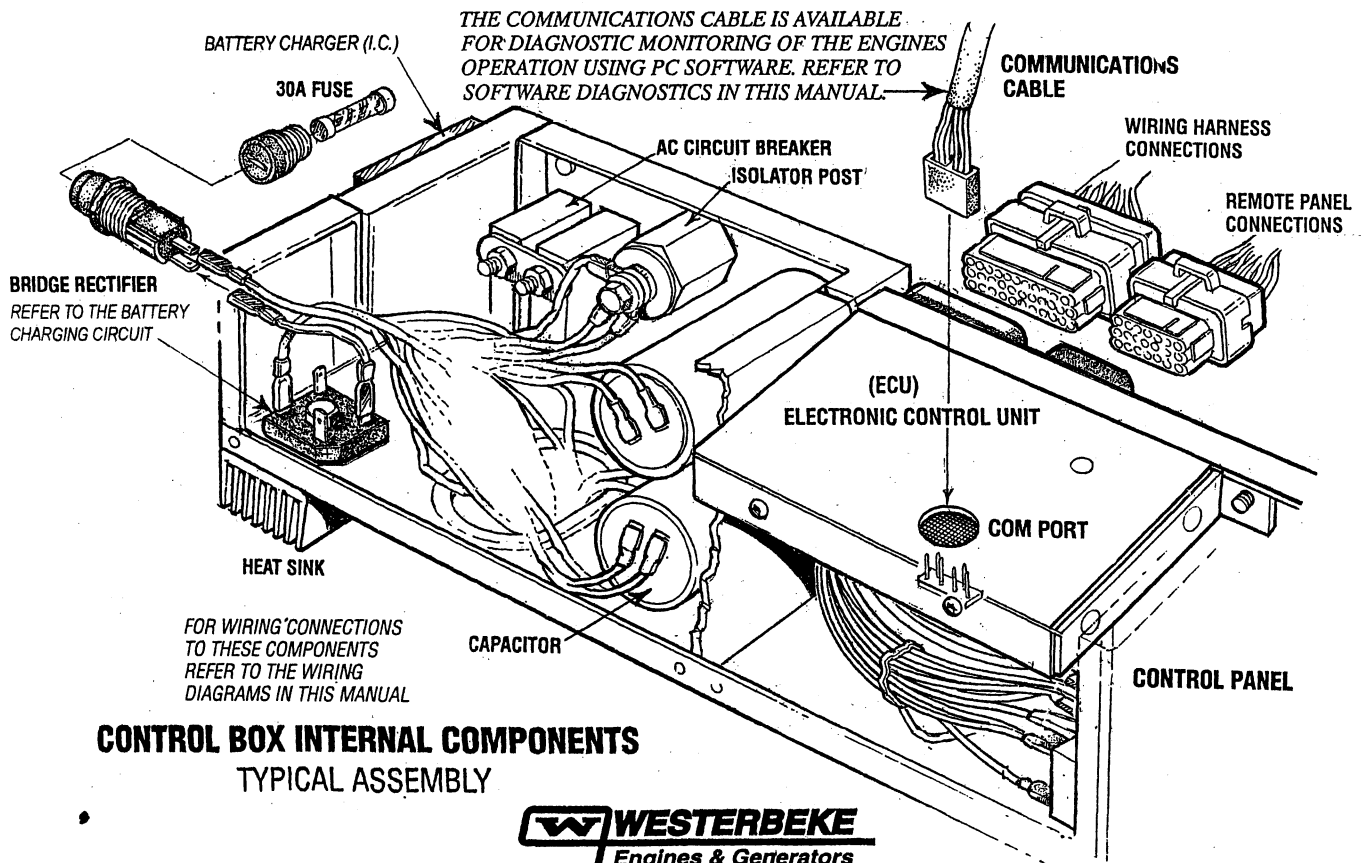
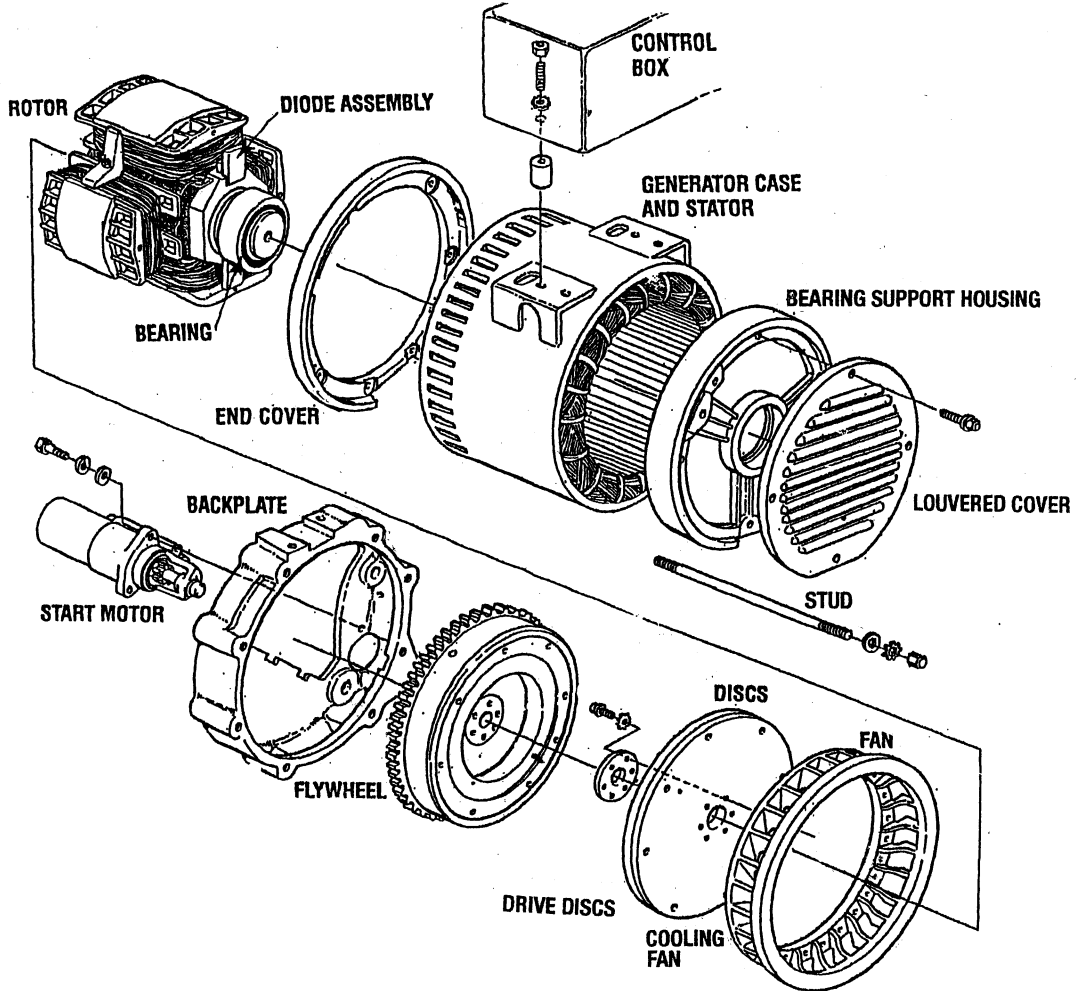

CONTROL BOX INTERNAL COMPONENTS
TYPICAL ASSEMBLY

BC GENERATORS TROUBLESHOOTING

NO AC VOLTAGE OUTPUT

EXCITING THE GENERATOR

To quickly determine a short or an open in the main stator winding, excite the generator with 12 VDC using one exciter winding group to accomplish this.

The AC voltage that the generator will produce measured between the line and neutral during excitation will be very low.

NORMAL AC VOLTAGE DURING 12 VDC EXCITATION:
12 - 16 VOLTS AC

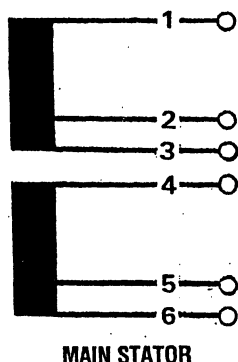

EXCITING PROCEDURE

Locate one of the exciter winding groups in the generator. Unplug all connections from both capacitors. Connect 12 VDC across the winding using the winding end connection, Winding group between #50Hz and #9.

EXCITER WINDINGS

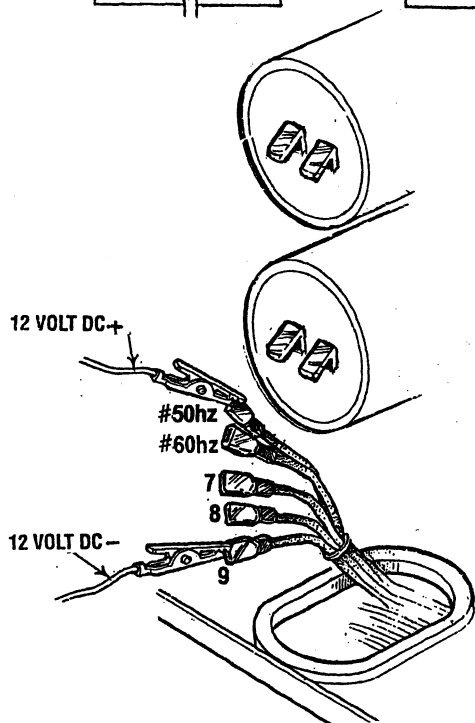
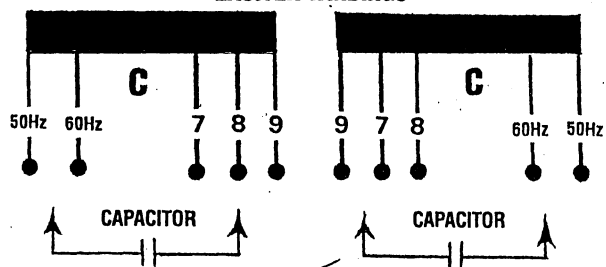

REACTION DURING EXCITATION

(Unit running - 12 VDC applied to winding)

NORMAL VOLTAGE DURING EXCITATION IS 12 - 16 VOLTS AC

1. A very low AC output and loading of the drive engine and a growling noise from the generator end. This indicates a shorted stator winding to ground or the stator windings are shorted to each other. Isolate the winding groups and verify a short to ground. No continuity should be found between the two isolated stator winding groups.
2. No reaction from the generator or drive engine. No AC output. This is an indication of an open in one of the main stator winding groups. Isolate the winding groups and verify and open winding.

No Continuity between Isolated Stator Winding Groups

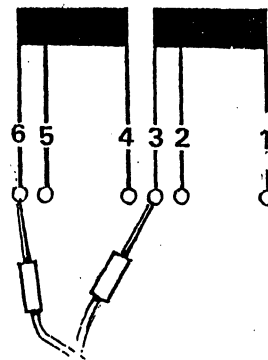

TEST EACH OF THE WINDING LEADS INDIVIDUALLY AS SHOWN

THERE SHOULD BE NO CONTINUITY BETWEEN LEADS

No Continuity between Isolated Stator Windings and Ground

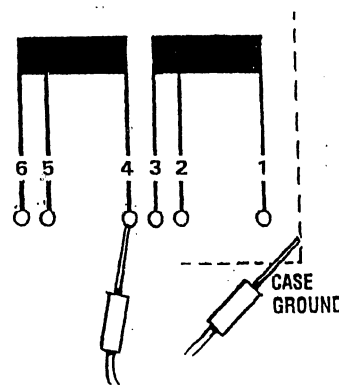

TEST EACH WINDING TO CASE GROUND

MAIN STATOR RESIDUAL VOLTAGE

Line to Neutral 4 - 6 VAC
(This indicates good stator windings)

BC GENERATOR SINGLE PHASE

TESTING THE DIODES

Carefully unsolder the thin connection to the diode and remove the diode using a then walled, deep well 7/16" (11mm) socket and a box wrench as needed.

Test the diode as shown with ohmmeter leads at both ends, then reverse the positions

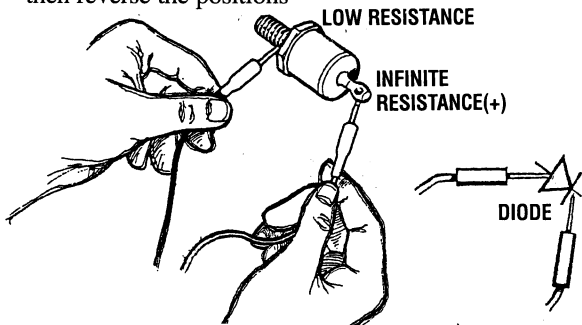

A low resistance should be found with the leads in one direction and infinite resistance (blocking) in the other direction.

DIODES: 1.4 - 1.5 OHMS (APPROX)
USING A 260 FLUKE 76 METER

Note that different meter models may show different ohm values, but should read the same for both diodes.

DIODES RATING 1600 VOLTS 26 AMPS

The diode's rating is far in excess of the circuit's requirements. Most likely a diode failure will result from a generator overspeed or load surge.

NO-LOAD AC VOLTAGE OUTPUT ADJUSTMENT

No-load AC voltage output can be adjusted up or down using one of the three numbered taps #7, #8, or #9. Moving up in the number sequence increases circuit excitation and increases AC output and the reverse when moving down the numbered sequence.

The #60 or #50 is plugged into one connection on the circuit capacitor to correspond to the hertz the unit is operating at. Either the #7, #8, or #9 can be plugged into the second connection. This connection on each exciter circuit's capacitor does not have to be the same for both. One circuit can have a #7 plugged into its capacitor and the other circuit a #9. Whatever combination gives the best No-Load AC output sought after. The un-used connector ends must be covered and tied off out of harms way.

CAUTION: Make all connection changes with the generator not operating as high AC voltage is present in these circuits while the generator is operating.

EXCITER CIRCUIT WITH DUAL CAPACITORS

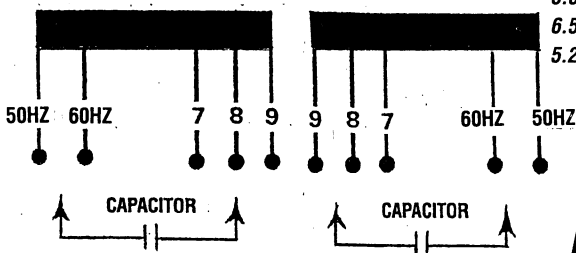

EXCITER CIRCUIT CAPACITORS
5.0/4.2 MCG #046875
6.5 MCG #049627
5.2 MCG #046639

AC/HERTZ CONVERSION

The MCG model BC style generators can be converted from 60 hertz 120 volt output to 50 hertz 230 volt output by following these procedures.

1. Turn OFF the AC breaker and the DC breaker on the Control Box. Open the Control Box on the generator. This will give you access to the AC output winding connections, Exciter Circuit connections and Battery Charge Circuit connections. All of which will need connection changes.
2. Reference the AC output configuration drawing below and configure the output leads as shown. AC circuit breaker may need to be replaced with a different rating. Breaker listing is below. **Be sure to properly position the Neutral to Gen. frame wire (white/green).** Failure to do so will result in a severe electrical short in the main stator windings.

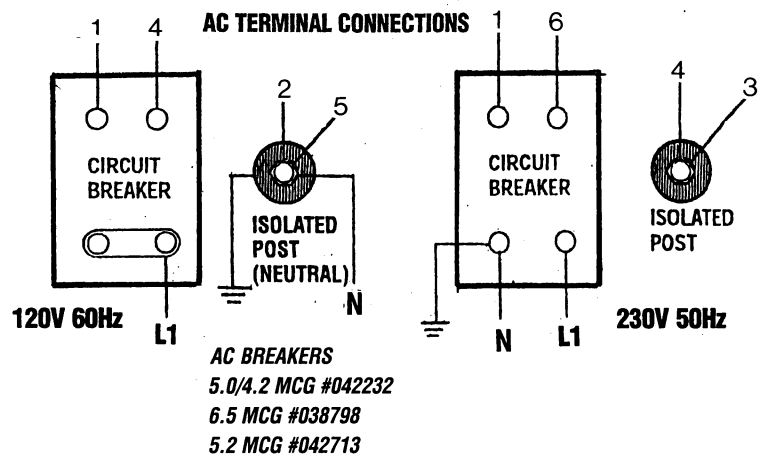

3. At the two exciter circuit capacitors, change the hertz connection on each either #50 to #60 or #60 to #50.
4. At the Battery Charge circuit, the hertz connection on the circuit's bridge rectifier needs to be changed to either the #50 or the #60 to correspond to the hertz selected.
5. The above completed, the ECU must be reprogrammed to the hertz selected. Refer to **Setting/Changing Engine Speed** (Hertz) discussed in this manual.

FUSE PROTECTION

Four DC circuit protectors are found in the engines electrical circuit. A 15 amp DC breaker and an 8 amp buss fuse on the control panel. A 30 amp buss fuse in the control panel and a 30 amp spade fuse by the starter motor for the battery charge circuit.

BATTERY CHARGING CIRCUIT

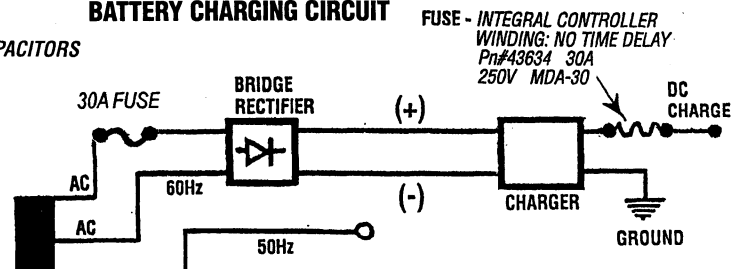

BC GENERATORS TROUBLESHOOTING CHART

A, B, C, & D refer to the components of the *INTERNAL WIRING DIAGRAM* and their test procedures in the following pages.

NOTE: This fault finding chart is compiled assuming the engine is operating at the correct speed/hertz.

FAULT	CAUSE	TEST/CORRECTION
No AC Output	Shorted stator	B
	Open stator	B
	Shorted diode (two)	A
Residual Voltage 4-6 VAC (Hot N) at No-Load	Faulty capacitor (two)	C
	Open exciter	B
	Shorted exciter	B
	Engine speed (hertz) is too low	Correct *
High AC Output at No-Load	Incorrect voltage tap on capacitor	C
	Incorrect capacitor	C
Low AC Output 60-160V	Incorrect hertz tap on capacitor	C
	Engine speed (hertz) too high.	Correct *
	Faulty rotor winding	A
	Faulty diode	A
Voltage Drop Under Load (or at No-Load)	Faulty capacitor	C
	Faulty diode	A
	Engine speed (hertz) is too low	Correct *
No Battery Charge	Faulty Bridge rectifier	D
Low Battery Charge	Faulty integral controller	D
	Blown fuse (s)	B
	Faulty wiring	B
	Engine speed (hertz) is too high	Correct *
High Voltage Output when Load is applied	Engine speed (hertz) is too high	Correct *
Unstable Voltage	Electrical connections are faulty, loose	Inspect wiring connections
Noisy Operation	Faulty support bearing	Inspect rear bearing**
	Generator rotor connection to engine is loose	Check rotor security**

* Refer to the *GENERATORS OPERATOR MANUAL*
 ** Refer to the *GENERATORS SERVICE MANUAL*

WINDING RESISTANCE VALUES (OHMS)

	5.0KW	6.5KW
MAIN STATOR:		
#1 TO #3	0.4	0.2
#4 TO #6	0.4	0.2
ROTOR: (Each pair)	4.0	2.0
EXCITER: (Each winding)	3.9	2.5
CHARGE WINDING:	0.4	0.4 (#50-AC)

INTERNAL WIRING SCHEMATIC

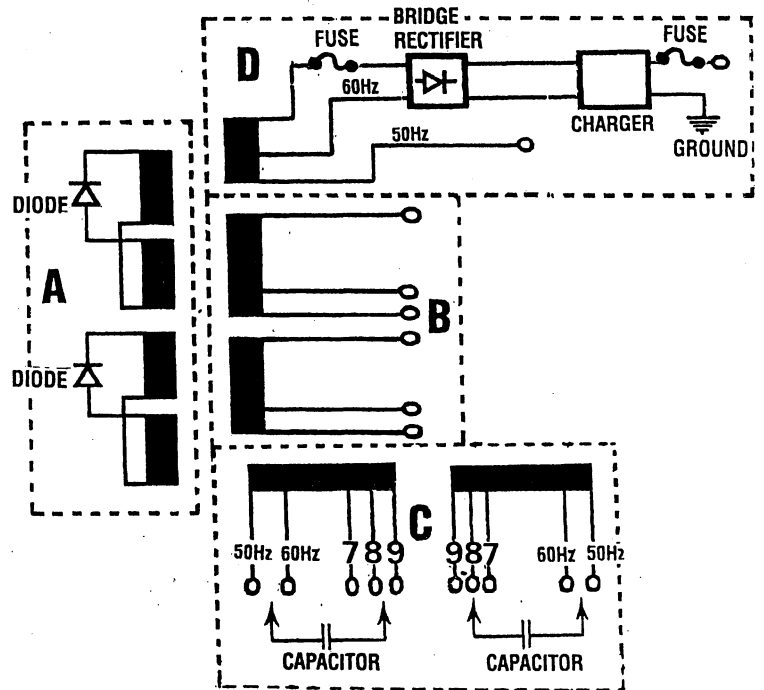

- A** - ROTOR WINDINGS
- B** - STATOR WINDINGS
- C** - CAPACITOR WINDING
- D** - BATTERY CHARGE WINDING

BC GENERATORS TROUBLESHOOTING

TESTING THE EXCITER WINDINGS

AC voltage can be measured across the capacitor electrical connections while the generator is operating. This voltage may be as high as 350 to 400 volts AC.

This AC voltage build-up is accomplished as the exciter winding for each capacitor charges the capacitor and the capacitor discharges back into the winding. This flow of saturating AC in the exciter winding produces a phase-imbalance type of field that affects the auxiliary windings of the rotor.

The AC voltage reading is taken between the two electrical connections on each separate capacitor with the generator operating at its correct no load speed.

MEASURING VOLTAGE GENERATOR RUNNING

SET THE METER DIAL AT AC VOLTS

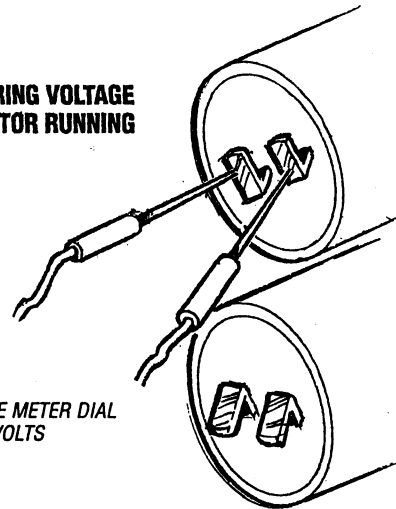

EXCITER WINDING INTEGRITY (RESIDUAL AC VOLTAGE)

The condition of each exciter winding can be determined by the residual AC voltage each exciter winding should be producing with the generator running at proper no load speed.

To do this: Unplug all connections from the capacitor. Locate the electrical connection for each winding end. Place your AC volt meter connects across these two connections. Start the generator and observe the residual AC voltage produced by the winding. Check the other exciter winding in the same way. Residual AC voltage lower than listed below will indicate a faulty winding.

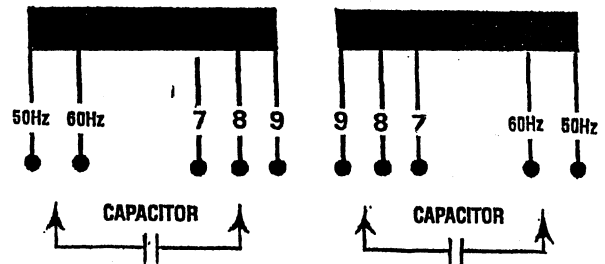

**RESIDUAL VOLTAGE (EACH WINDING GROUP)
MEASURED BETWEEN #50 AND #9 OF EACH GROUP
7-9 VOLTS AC.**

TESTING WINDING LEADS FOR NO CONTINUITY TO METAL CASE

THERE SHOULD BE NO CONTINUITY BETWEEN LEADS 50HZ AND #9 TO CASE GROUNDS

MEASURE THE RESISTANCE VALUE OF THE EXCITER WINDINGS BETWEEN THE END LEADS OF EACH WINDING

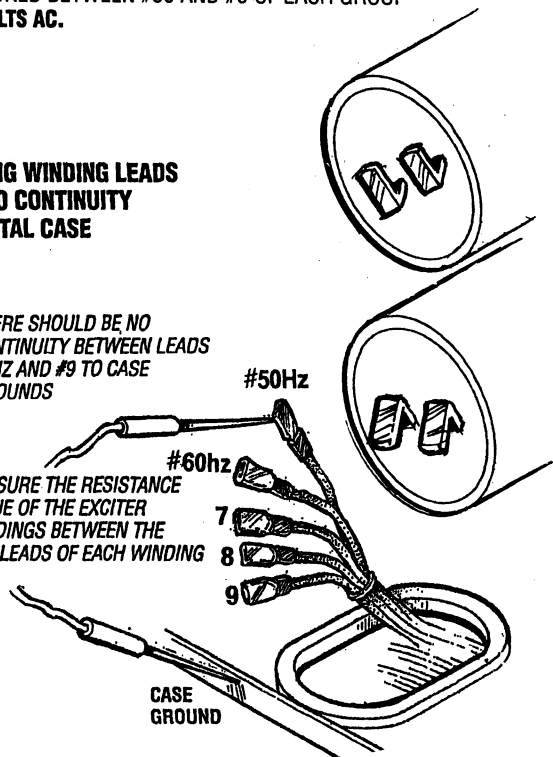

BC GENERATORS TROUBLESHOOTING

TESTING CONTINUITY

Quick field check (no capacitance scale on meter).

Connect a digital ohm meter or analog ohm meter (high scale) to the capacitor terminals. The meter will register an arbitrary ohm value for the material in the capacitor. The meter's battery will then start to charge the capacitor and the ohm value will increase.

If the meter does not react as above, the capacitor is faulty.

The method above indicates a presumably good capacitor, but does not verify its microfarad rating as would be necessary when troubleshooting a capacitor whose MF rating has dropped causing a low AC voltage output. In such cases, the capacitor's rating *MUST* be verified accurately.

⚠ WARNING: Capacitors must be discharged before handling as they store electricity and can pack a potentially lethal charge even when disconnected from their power source.

DISCHARGING THE CAPACITOR

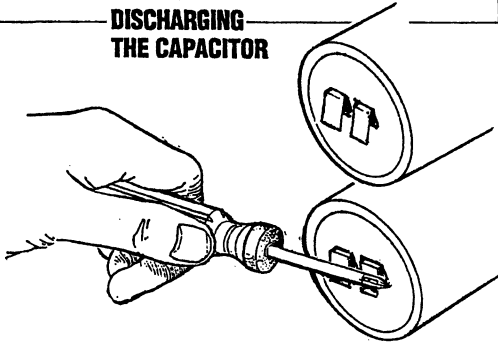

TESTING THE CAPACITOR(S)

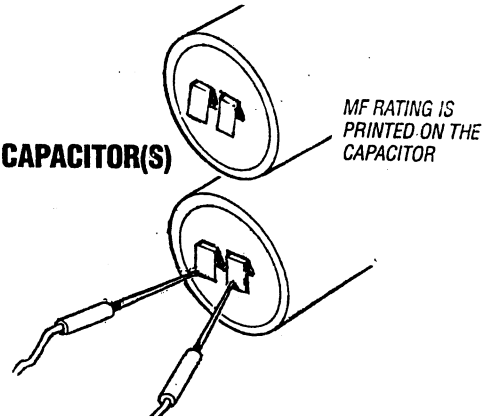

CAPACITOR RATINGS AND PART NUMBERS

25MFD	Pn. #046875
31.5MFD	Pn. #046978
35MFD	Pn. #046875
40MFD	Pn. #054730
18MFD	Pn. #039556
45MFD	Pn. #046801

NOTE: When changing a capacitor due to a capacitor failure, reference the capacitor rating as printed on the body of the capacitor and order the correct replacement. Installing a capacitor of a higher MFD rating will result in high AC output voltage and installing a capacitor of a lower MFD rating will result in low AC output voltage.

TESTING THE BC ROTOR

TESTING THE ROTOR FIELD WINDINGS

Unsolder the winding connection from the diode and carefully remove the diode from its isolated heat sink using a thin walled, deep well 7/16" (11mm) socket.

With the diode removed, both leads for the first group of rotating field/auxiliary windings will be isolated with no interference from a possibly faulty diode.

Check the resistance value of the rotating windings by placing an ohmmeter's probes across the two exposed leads.

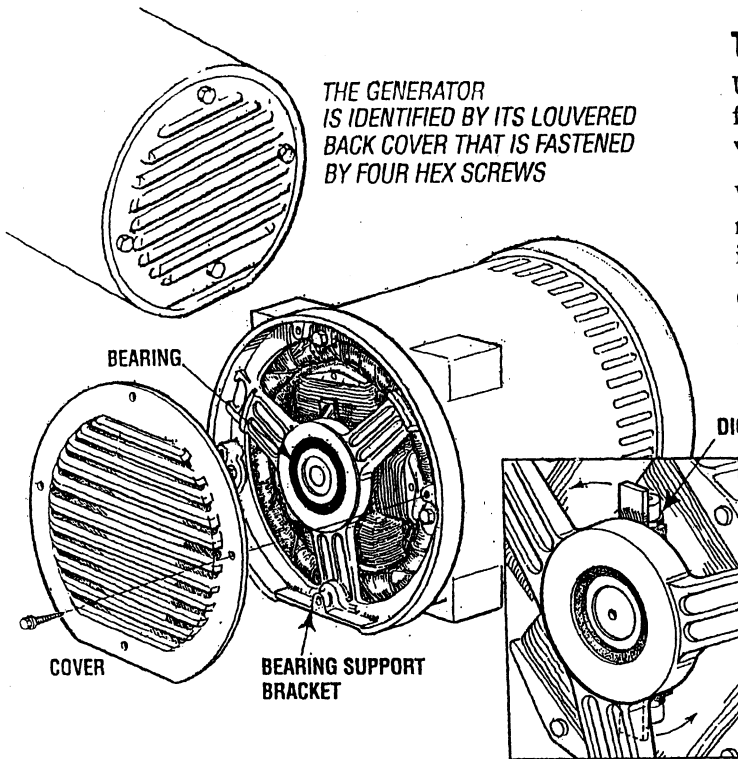

Testing the generator can be accomplished without removing the bearing support bracket. Simply turn the armature to allow access for the testing as shown.

TESTING THE WINDINGS THROUGH THE DIODES

Rotate the armature into position to access a diode. To make a quick test of the windings, assume the diode to be OK and test the connection at each end of the diode. Turn the armature and test the other side.

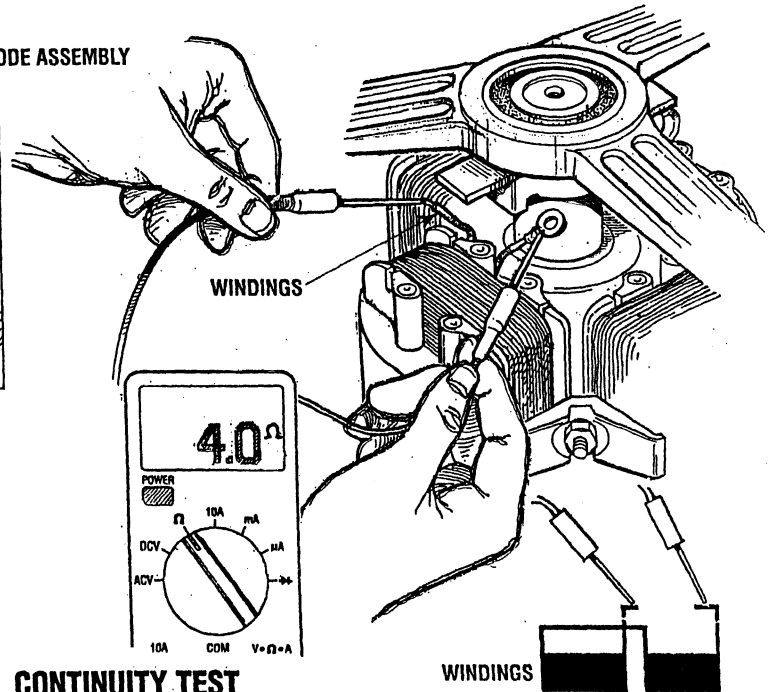

CONTINUITY TEST

Check that no continuity exists between either of the winding leads and the generator shaft. If continuity is found, there is a short in the windings.

Repeat these tests on the second set of windings on the opposite side.

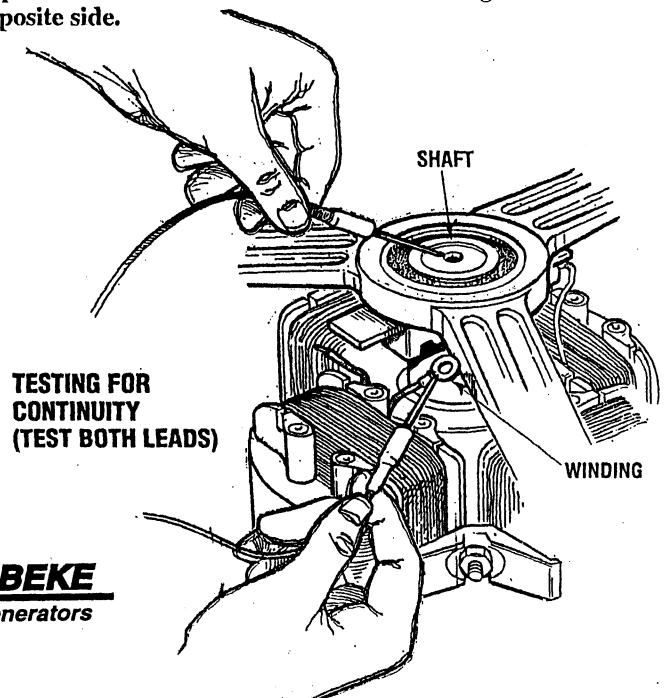
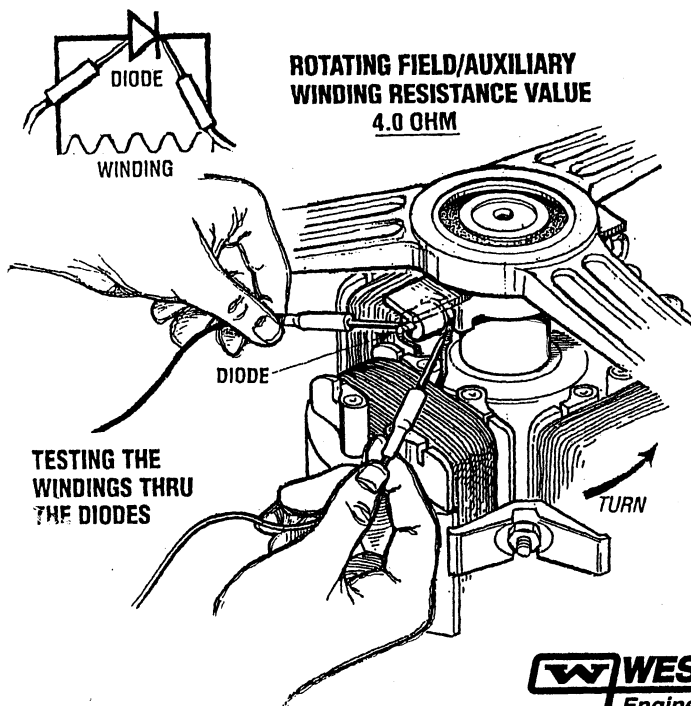

SPECIAL TOOLS - GENERATOR

FIELD FABRICATED TOOLS

These drawings provide a means by which simple tools can be made to assist in the removal of the generator end from the engine and in the replacement of the generator end on the engine. A local machine shop should be able to fabricate these tools at a modest price, but first check with your local WESTERBEKE dealer to see if these tools are on hand for loan.

Housing Puller Tool

This tool allows the bearing in the generator housing to be gently pushed straight off the housing without any twisting. If a nut of the same specifications as that of the tapped hole in the pilot tool were to be welded on the end of the eye bolt, this tool would be able to pull the bearing back into place without any twisting. Please refer to these drawings before the generator end is removed.

HOUSING PULLER TOOL (FIELD FABRICATED)

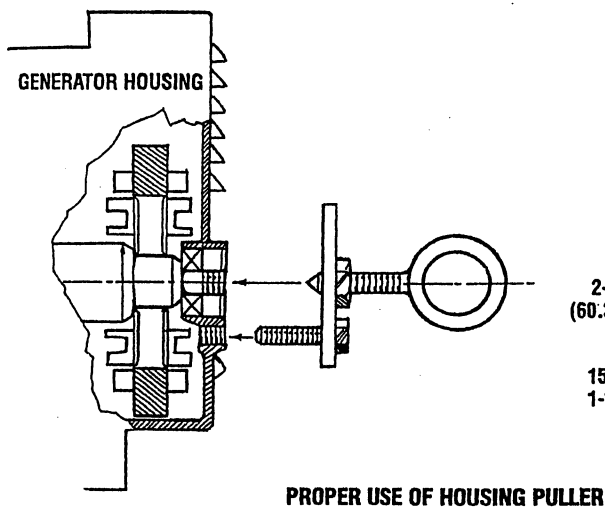
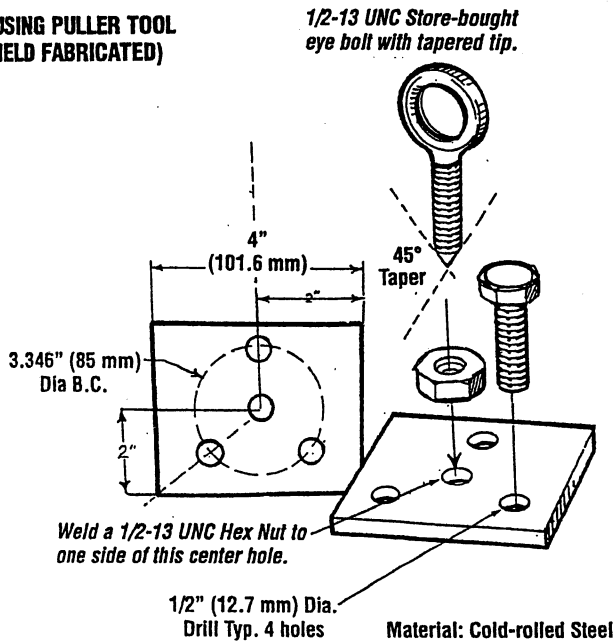

Lifting Eye Tool

This tool allows a mechanic to safely remove the generator end from the engine by attaching this Generator End Lifting Eye to the four screw holes located under the control panel. To use this Lifting Eye, remove the generator's control panel and screw the Lifting Eye to the generator end.

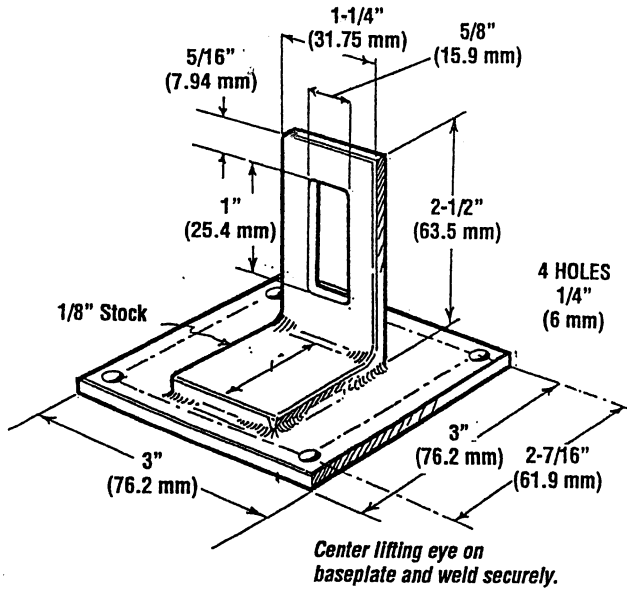

Disk Alignment Tool

This tool allows a mechanic to safely remove and install the generator drive disks by aligning the disks with the Drive Plate Guide Pin. The Pin screws into the flywheel and acts as a guide. Also the pin helps to support some of the rotor and the drive plate's weight while removing or replacing these parts.

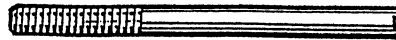

Material: One M8 bolt with the hex head machined off and a screwdriver slot cut in the machined end.

Pilot Tool

Screwed into the end of the rotor shaft, this tool can be used to pull the stator assembly away from the engine without damaging the stator windings. This tool can be used at reassembly.

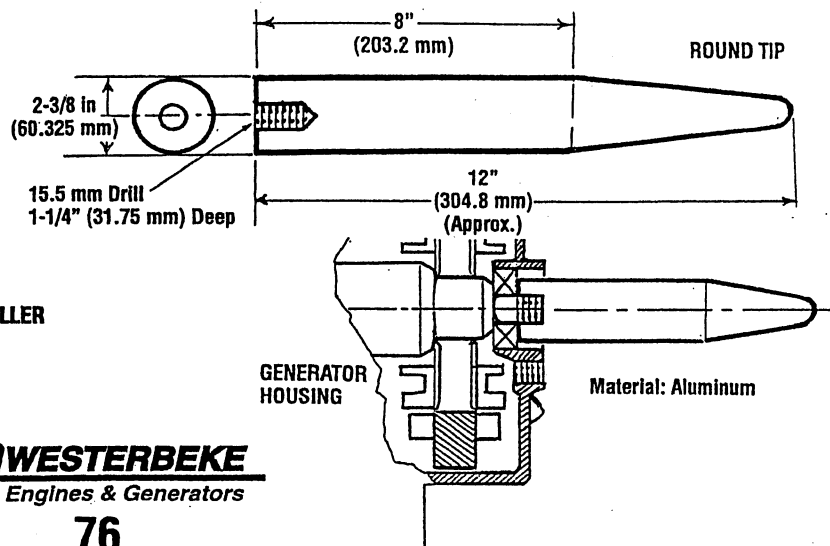

SHORE POWER TRANSFER SWITCH

SINGLE LINE 120 VOLT SYSTEM

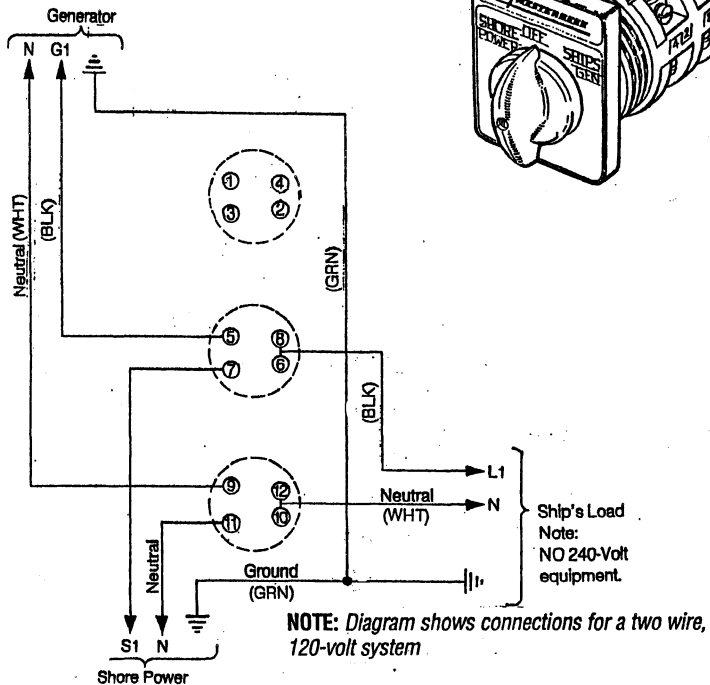

NOTE: Ship to shore switches are available at your WESTERBEKE dealer.

230 VOLT/50 HERTZ TWO WIRE CONFIGURATION

Notice the repositioning of the white wire ground load on the terminal block to the generator case.

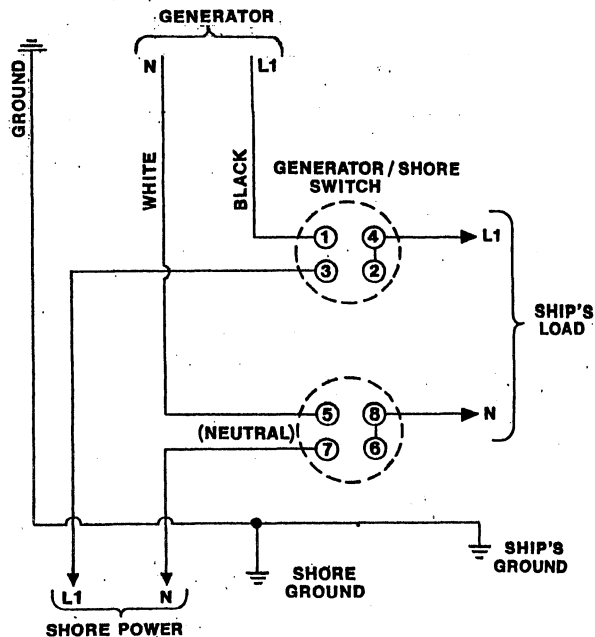

If the installer connects shore power to the vessel's AC circuit, this must be done by means of the Shore Power Transfer Switch. Set the transfer switch shown in the diagrams to the OFF position. This switch prevents simultaneous connection of shore power to generator output.

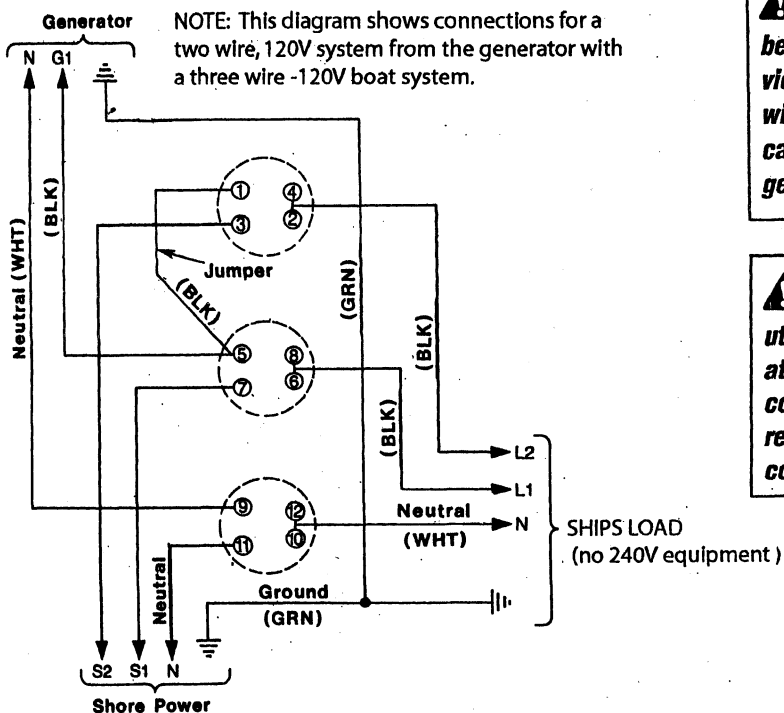

Switching Shore Power to Generator Power

CAUTION: Heavy motor leads should be shut off before switching shore power to generator power or vice-versa because voltage surges induced by switching with heavy AC loads on the vessel being operated may cause damage to the exciter circuit components in the generator.

CAUTION: Damage to the generator can result if utility shore power and generator output are connected at the same time. This type of generator damage is not covered under the warranty; it is the installer's responsibility to make sure all AC connections are correct.

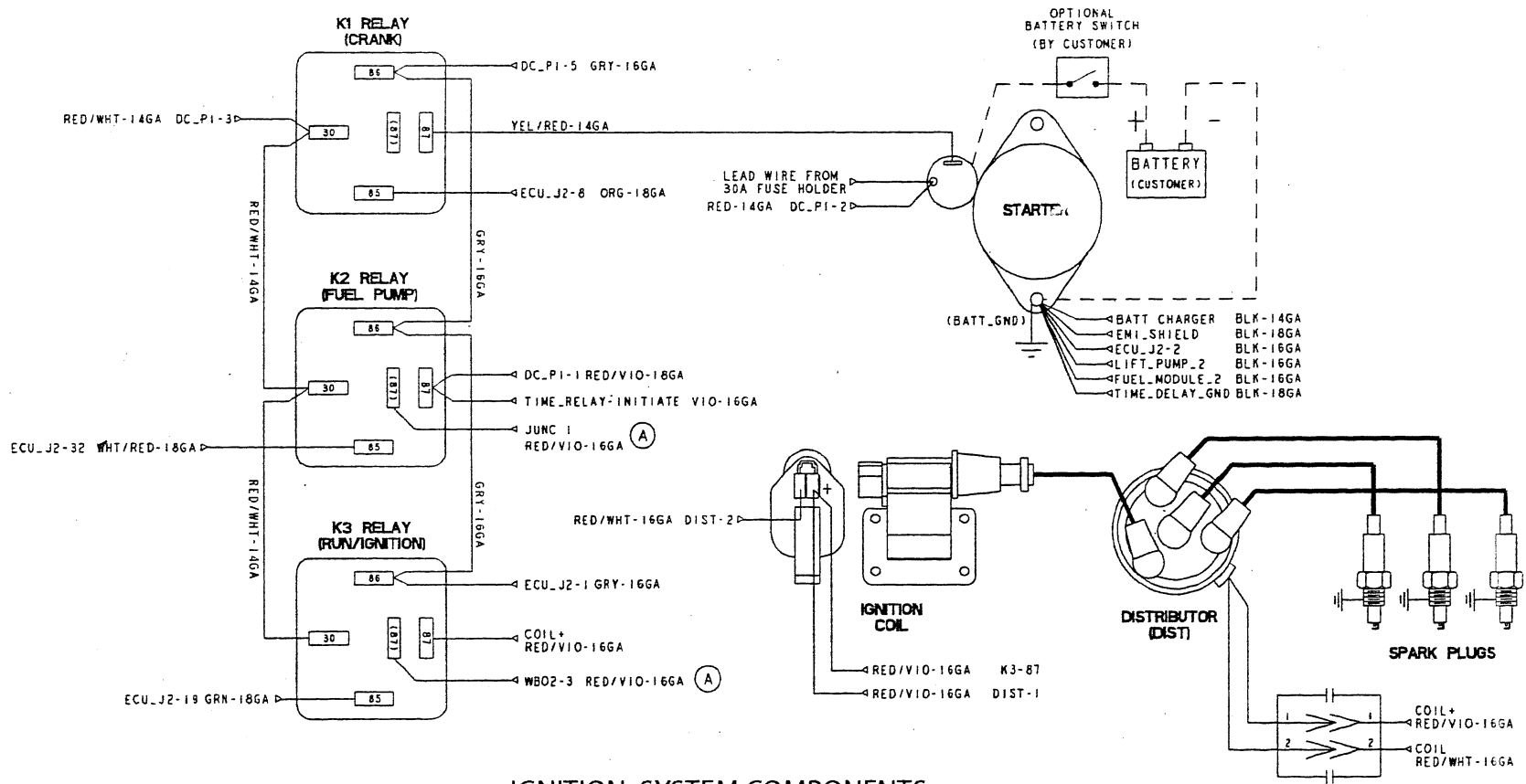

IGNITION SYSTEM COMPONENTS

WIRING DIAGRAM #55536

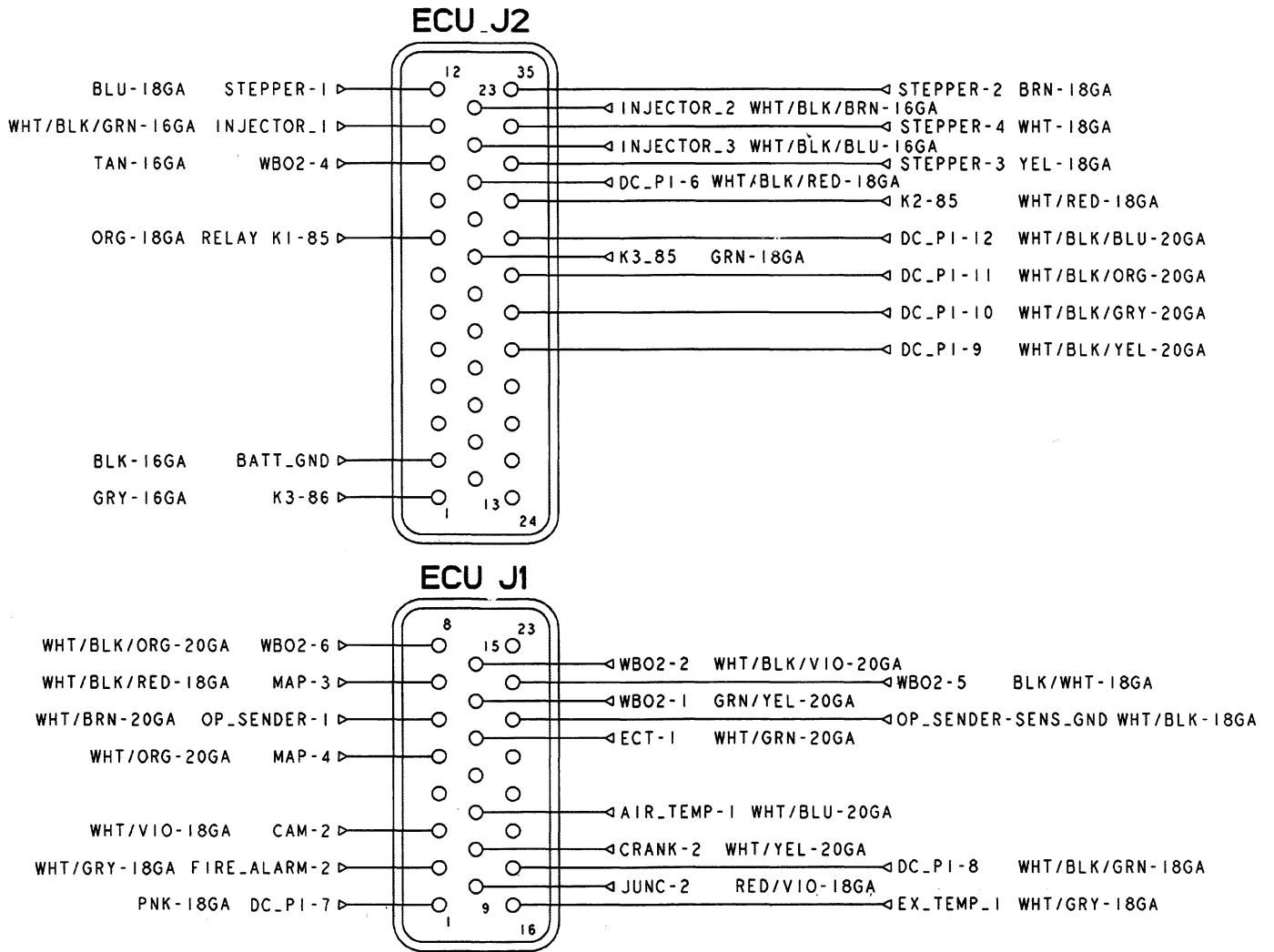

ECU CONNECTIONS

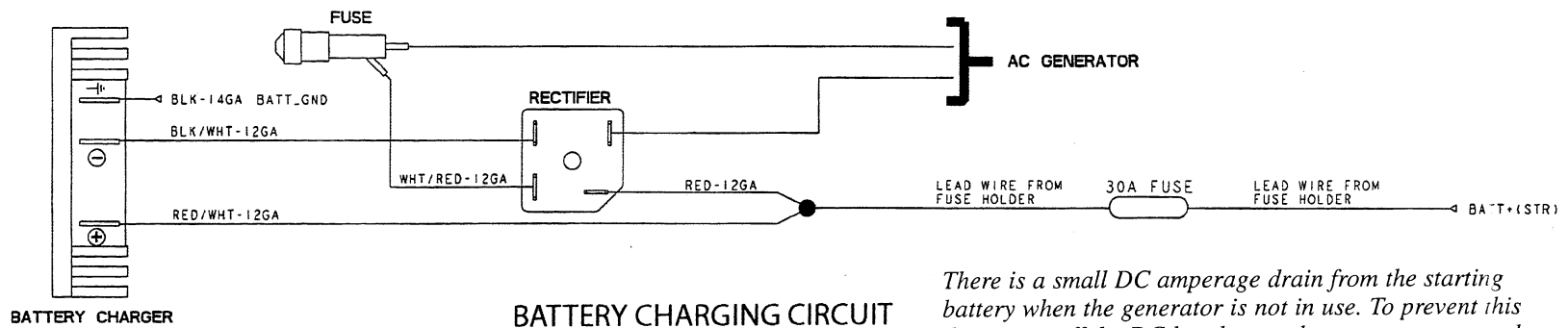
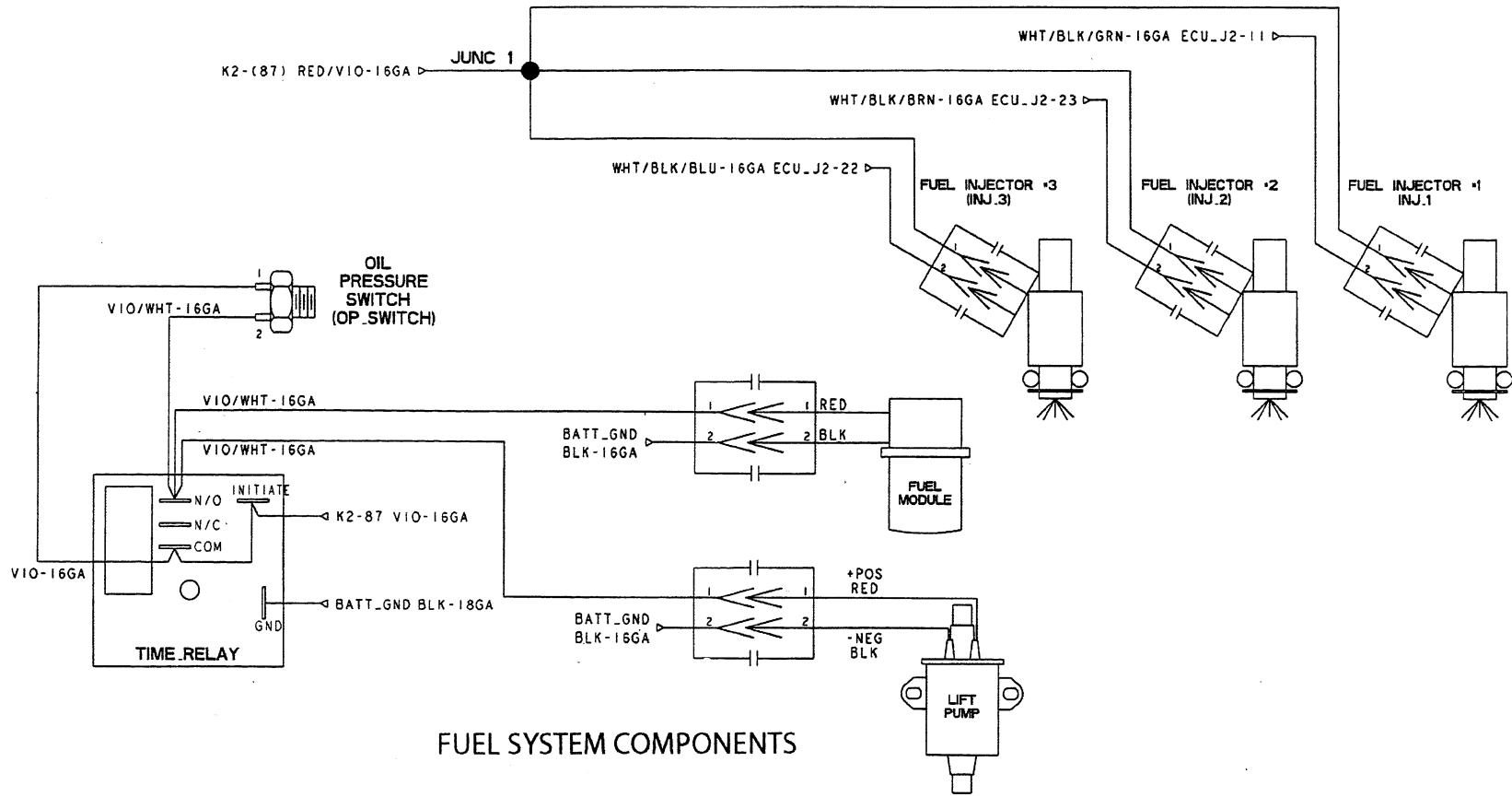

There is a small DC amperage drain from the starting battery when the generator is not in use. To prevent this draw, turn off the DC breaker on the generators control panel (or turn off the DC battery switch to the generator).

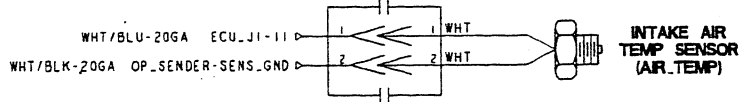
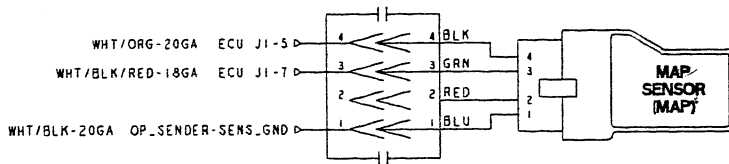
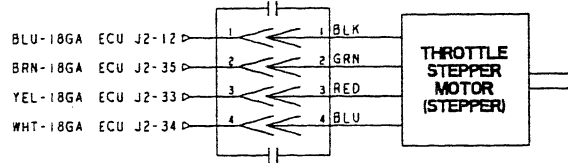
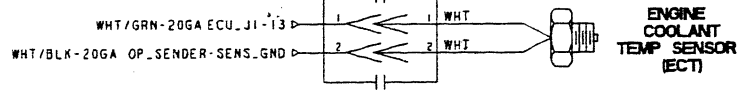

COMPONENTS LOCATED ON THE INTAKE THROTTLE BODY

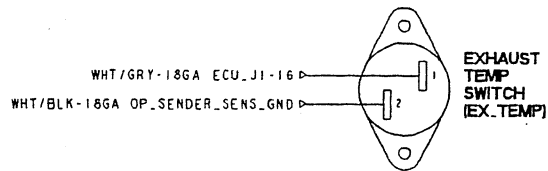

EXHAUST SYSTEM COMPONENTS

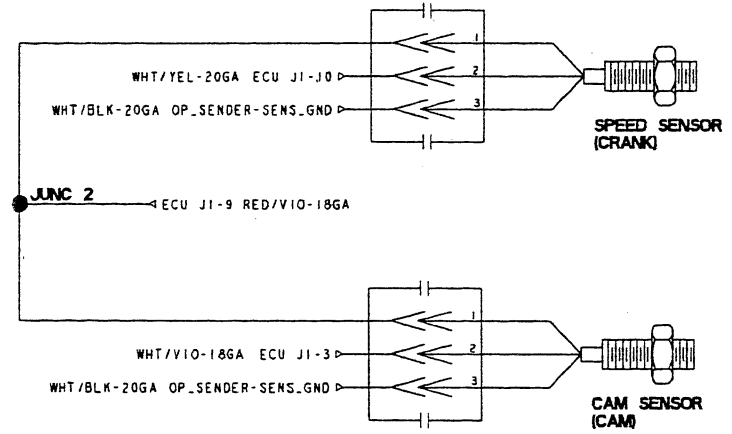
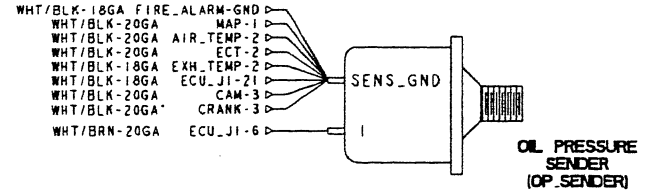

ENGINE BLOCK COMPONENTS

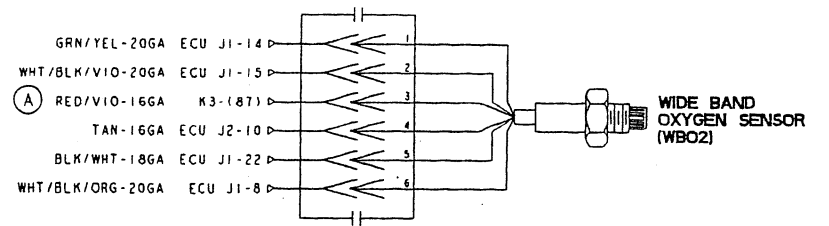

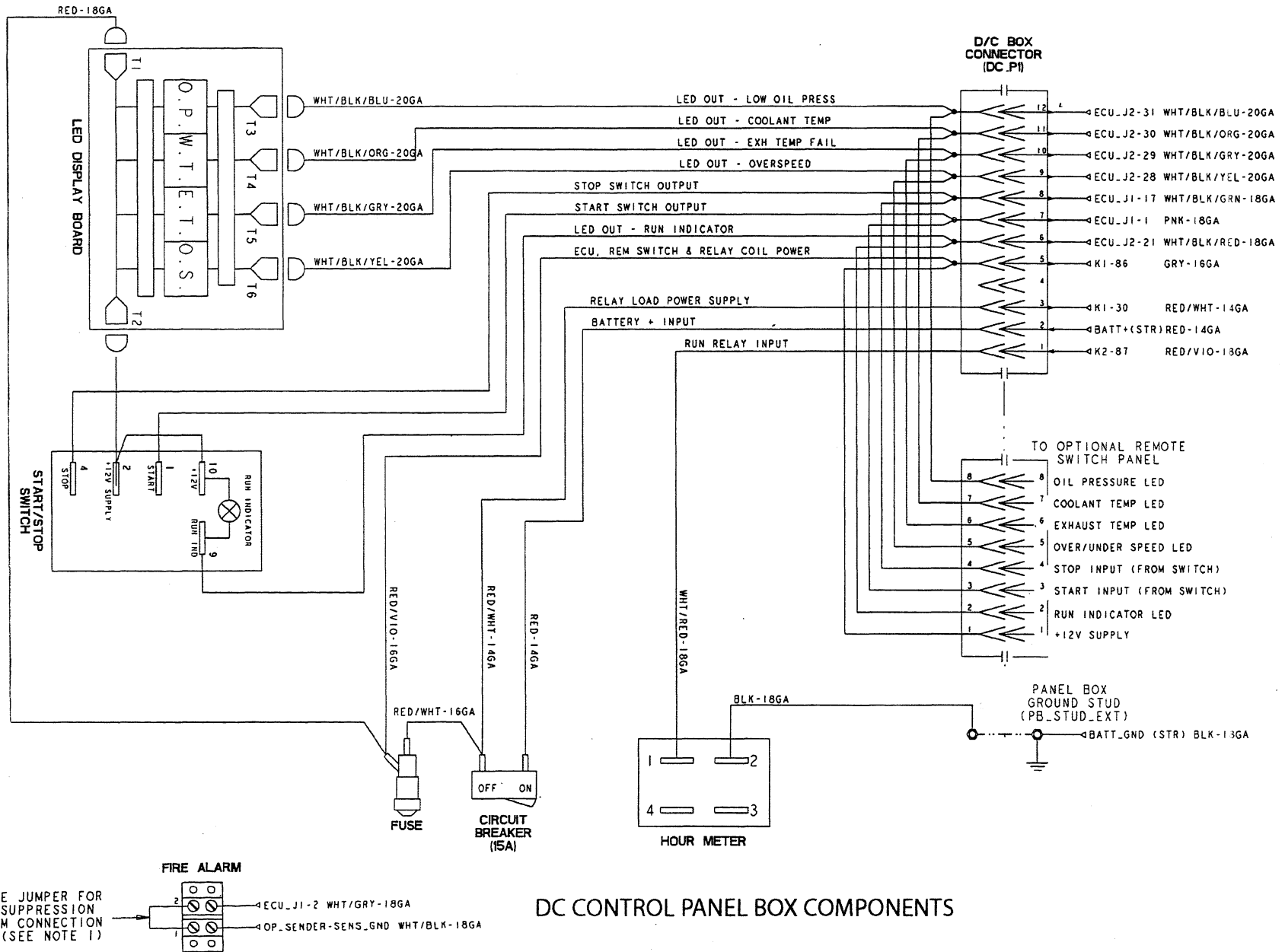

DC CONTROL PANEL BOX COMPONENTS

NOTES:
1. FIRE SUPPRESSION SYSTEM CONNECTION IS NOT A POWER SOURCE. THIS CIRCUIT MUST BE CLOSED TO RUN. AN OPEN CIRCUIT WILL STOP THE GENSET.

DC AUXILIARY POWER ADAPTER

DESCRIPTION

This auxiliary power adapter is designed to plug-in the engine wiring harness where the electric fuel pump is connected. Simply turn off the DC power using the breaker on the control panel. Unplug the electric fuel pump, connect the adapter and connect the fuel pump to one of the adapter plugs. Cut off the other plug and strip back the wires and maintaining polarity (violet + and black -), connect to the relay that will be supplying DC power to the auxiliary component. Re-set the DC power breaker on the control panel.

NOTE: This auxiliary connection provides DC power ONLY when the engine is running or when priming the fuel system. The maximum DC amperage available from this circuit is 200 MILLIAMPS.

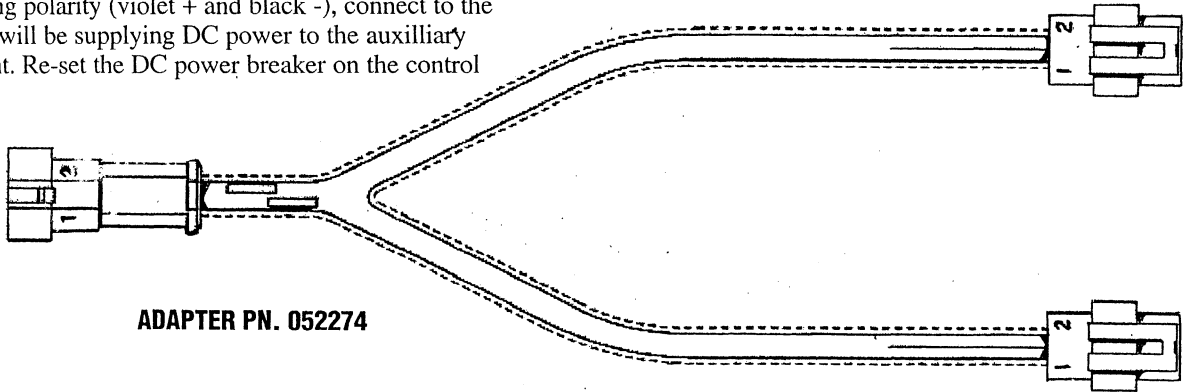

REMOTE PANELS WIRING

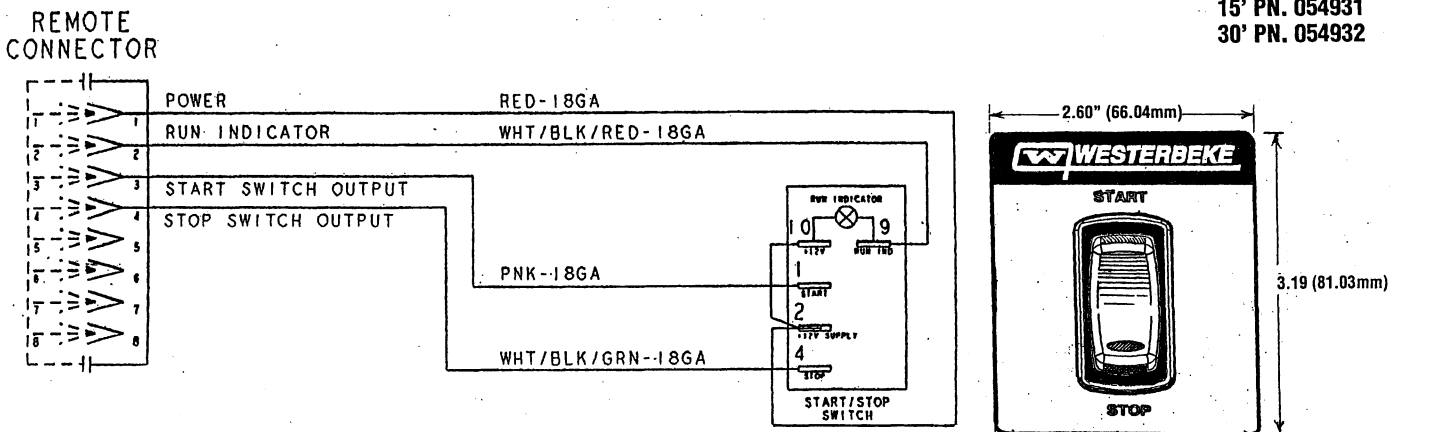
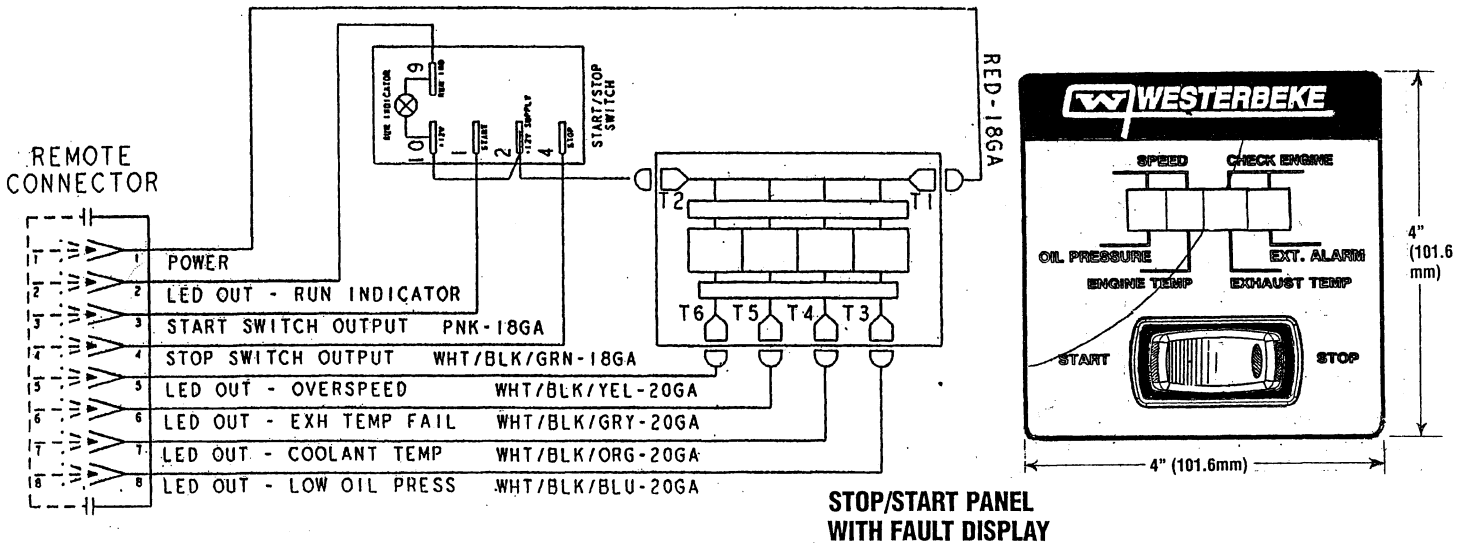

STOP/START PANEL
ROCKER SWITCH ONLY

REMOTE OIL FILTER (OPTIONAL) PN.040078

INSTALLATION

This popular accessory is used to relocate the engine's oil filter from the engine to a more convenient location such as an engine room bulkhead.

NOTE: Refer to *ENGINE OIL CHANGE* in this manual for instructions on removing the oil filter.

To install, simply remove the engine oil filter and thread on WESTERBEKE's remote oil filter kit as shown. Always install this kit with the oil filter facing down as illustrated. Contact your WESTERBEKE dealer for more information.

NOTE: *Westerbeke is not responsible for engine failure due to incorrect installation of the Remote Oil Filter.*

⚠ CAUTION: *It is vital to install the oil lines correctly. If the oil flows in the reverse direction, the bypass valve in the filter assembly will prevent the oil from reaching the engine causing an internal engine failure. If there is no oil pressure reading, shutdown immediately and check the hose connections.*

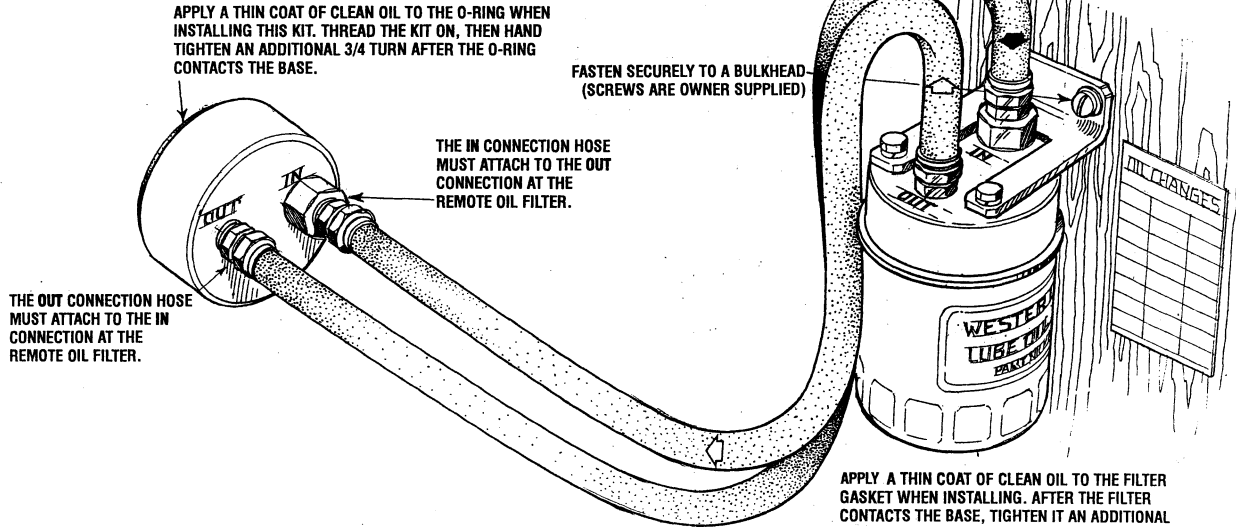

MCG GENERATOR SPECIFICATIONS

ENGINE SPECIFICATIONS

Engine Type	3-cylinder, 4-cycle, , overhead camshaft w/counterbalance shaft, water cooled gasoline engine.
Bore & Stroke	2.56 x 2.61 inches (65.0 x 66.3 mm).
Total Displacement	40.3 cubic inches (0.66 liters).
Bearings	Four main bearings.
Compression Chamber	Semi-spherical.
Compression Ratio	9.8:1.
Hp@1800/1500 rpm	10.0.
Firing Order	1 - 3 - 2.
Aspiration	Naturally aspirated.
Direction of Rotation	Counterclockwise viewed from the back end.
Inclination	25° continuous, all directions.
Dry weight	<i>Refer to the sales brochure.</i>
Governor	Electronic.

FUEL SYSTEM

General	Multi-port fuel injection.
Fuel	Unleaded gasoline with an octane rating of 89 or higher. (Ethanol blend not to exceed 10%)
Fuel Consumption (full load) approximate	5.0 MCG (.74 gph) 4.2 MCD (.63 gph) 6.5 MCG (.76 gph) 5.2 MCG (.71 gph)
Fuel Hose Size (supply and return)	1/4" I.D. minimum - 3/8" I.D. maximum.
Fuel Pump	12 volt electric (high/low pressure).
Fuel Filter (on engine)	Replaceable cartridge-canister type.
Air Cleaner (flame arrester)	Metal screen type - cleanable.

ELECTRICAL SYSTEM

Start Battery	12 Volt, (-) negative ground Battery must be totally dedicated to the generator and maintained only by the DC charge controller system in the AC generator.
Starting Capacity	800-1000 Cold Cranking Amps (CCA) (minimum).
Starter	12 Volt, reduction-solenoid mounted.
DC Charging	Solid state controller, 12 amp rated.
DC Cold Cranking Amps	150-176 amps.

AIR REQUIREMENTS

Generator Cooling	225 -250 CFM (6.3 - 7.0 cmm).
Engine Combustion (all models)	22.9 CFM (0.6 cmm).
Engine Cooling	100 CFM (2.8 cmm).

NOTE: Forced ventilation should be provided to maintain the generators compartment temperature below 122° F (50° C)

COOLING SYSTEM

General	Fresh water-cooled block through raw water-cooled heat exchanger circuit.
Fresh Water Pump	Centrifugal type, metal impeller, belt-driven.
Raw Water Pump	Positive displacement, rubber impeller, belt-driven.
Raw Water Flow	4.9 US gpm (18.5 liters) @ 1800 rpm (approx. measure before discharging into exhaust elbow).
Cooling Water Capacity	3.5 qts (3.3 liters).
Operating Temperature	150° - 170° F (65 - 77° C).

LUBRICATION SYSTEM

General	Forced lubrication by gear pump.
Oil Filter	Full flow, paper element. spin-on disposals.
Oil Capacity	3.0 qts. (2.8 liters).
Operating Oil Pressure	30 - 45 psi (2.1 - 3.1 kg/cm ²).
Oil Grade	API Service Category SJ, SL, SM or SN SAE 40W ONLY (No Multi-Weight oils).

AC GENERATOR (Single Phase)

Single Phase	Brushless, four-pole capacitor, regulated. 1800 rpm/60Hz, 1500 rpm/50Hz.
Ratings:	
4.2KW	230 volts, 18.2 amps, 50Hz single phase, 4 wire, 1.0 power factor.
5.0KW	120 volts, 41.6 amps, 60Hz single phase, 4 wire, 1.0 power factor.
5.2KW	230 volts, 22.6 amps, 50Hz single phase, 4 wire, 1.0 power factor.
6.5KW	120 volts, 54 amps, 60Hz single phase, 4 wire, 1.0 power factor.

IGNITION SYSTEM

General	Battery Ignition 12 volts negative ground. Distributor with ignition module and ignitor. Ignition coil and spark plugs.
Distributor	Solid state type with signal generator and ignitor.
Spark Plug Thread Gap	11mm x 1.25 pitch.
Spark Plug Gap	0.028 - 0.031 inches (0.7 - 0.8mm)
Ignition Timing	15° BTDC at 1800 RPM ± 1° (Vacuum advance hose connected).
Spark Plugs	14mm.
Ignition Coil	12 volt.
Distributor	Breakerless with ignitor and pick-up assembly.

STANDARD HARDWARE TORQUES

NOTE: Unless stated otherwise for a specific assembly, use the following torque values when tightening standard hardware.

Grade 4	Pitch	lb-ft	kg-m
6mm bolt head/nut	1	2.9-5.1	0.4-0.7
8mm bolt head/nut	1.25	7.2-11.6	1.0-1.6
10mm bolt head/nut	1.25	13.7-22.4	1.9-3.1
10mm bolt head/nut	1.5	13.0-21.7	1.8-3.0
12mm bolt head/nut	1.25 (ISO)	25.3-39.8	3.5-5.5
12mm bolt head/nut	1.5	25.3-39.8	3.5-5.5
12mm bolt head/nut	1.75	21.7-36.2	3.0-5.0
13mm bolt head/nut	1.5	32.5-50.6	4.5-7.0
14mm bolt head/nut	1.5	36.2-57.9	5.0-8.0
14mm bolt head/nut	2	34.0-55.7	4.7-7.7
16mm bolt head/nut	1.5	54.2-79.6	7.5-11.0
16mm bolt head/nut	2	51.4-76.7	7.1-10.6
Grade 6T			
6mm bolt head/nut	1	4.3-6.5	0.6-0.9
8mm bolt head/nut	1.25	10.8-15.9	1.5-2.2
10mm bolt head/nut	1.25	21.7-32.5	3.0-4.5
10mm bolt head/nut	1.5	19.5-30.4	2.7-4.2
12mm bolt head/nut	1.25 (ISO)	36.2-57.9	5.0-8.0
12mm bolt head/nut	1.5	36.2-50.6	5.0-7.0
12mm bolt head/nut	1.75	34.7-49.2	4.8-6.8

Grade 7T, 8T and 8.8	Pitch	lb-ft	kg-m
6mm bolt head/nut	1	5.8-8.7	0.8-1.2
8mm bolt head/nut	1.25	14.5-21.7	2.0-3.0
10mm bolt head/nut	1.25	28.9-39.8	4.0-5.5
10mm bolt head/nut	1.5	26.8-37.6	3.7-5.2
12mm bolt head/nut	1.25 (ISO)	54.2-75.9	7.5-10.5
12mm bolt head/nut	1.5	50.6-65.1	7.0-9.0
12mm bolt head/nut	1.75	43.4-61.5	6.0-8.5
13mm bolt head/nut	1.5	57.9-86.8	8.0-12.0
14mm bolt head/nut	1.5	72.3-108.5	10.0-15.0
14mm bolt head/nut	2	68.7-101.3	9.5-14.0
16mm bolt head/nut	1.5	108.5-166.4	15.0-23.0
16mm bolt head/nut	2	101.3-159.1	14.0-22.0
Grade 5 Cap Screw			
1/4 UNC		9-11	1.2-1.5
1/4 UNF		11-13	1.5-1.8
5/16 UNC		18-20	2.5-2.8
5/16 UNF		21-23	2.9-3.2
3/8 UNC		28-33	3.7-4.6
3/8 UNF		30-35	4.1-4.8
7/16 UNC		44-49	6.1-6.8
7/16 UNF		50-55	6.9-7.6
1/2 UNC		68-73	9.4-10.1
1/2 UNF		73-80	10.1-11.1

BOLT DIAMETER	BOLT HEAD MARK		
	4	7	10
M6	0.3 - 0.5	0.8 - 1.0	1.0 - 1.3
M8	1.0 - 1.3	1.5 - 2.2	2.5 - 3.5
M10	1.8 - 2.5	3.0 - 4.2	5.0 - 7.0
M12	3.0 - 4.2	5.5 - 7.5	9.5 - 12.0
M14	5.0 - 7.0	8.0 - 11.0	16.0 - 19.0

PARTS REQUIRING SEALANT	SURFACES REQUIRING SEALANT (where to mount sealant coated parts)	SEALANT
Taper Screw 1/2"	Thread portion (Gear Case)	Liquid Teflon
Taper Screw 1/4"	Thread portion (Cylinder Block right side, pump cover)	Liquid Teflon
Taper Screw 1/8"	Thread portion (Cylinder Head rear surface)	Liquid Teflon
Water Drain Plug	Thread portion (Cylinder Block right side, rear middle portion)	Liquid Teflon
Oil Pressure Switch	Thread portion (Cylinder Block right side surface)	Liquid Teflon
Side Seal	Periphery (Main Bearing Caps No. 1 and No. 5)	Permatex #6B
Bearing Cap No. 1	Contact surface with Cylinder Block	Permatex #6B

DECIMAL TO METRIC EQUIVALENT CHART

Fractions of an inch	Decimal (in.)	Metric (mm)	Fractions of an inch	Decimal (in.)	Metric (mm)
1/64	0.015625	0.39688	33/64	0.515625	13.09687
1/32	0.03125	0.79375	17/32	0.53125	13.49375
3/64	0.046875	1.19062	35/64	0.546875	13.89062
1/16	0.0625	1.58750	9/16	0.5625	14.28750
5/64	0.078125	1.98437	37/64	0.578125	14.68437
3/32	0.09375	2.38125	19/32	0.59375	15.08125
7/64	0.109375	2.77812	39/64	0.609375	15.47812
1/8	0.125	3.175	5/8	0.625	15.87500
9/64	0.140625	3.57187	41/64	0.640625	16.27187
5/32	0.15625	3.96875	21/32	0.65625	16.66875
11/64	0.171875	4.36562	43/64	0.671875	17.06562
3/16	0.1875	4.76250	11/16	0.6875	17.46250
13/64	0.203125	5.15937	45/64	0.703125	17.85937
7/32	0.21875	5.55625	23/32	0.71875	18.25625
15/64	0.234375	5.95312	47/64	0.734375	18.65312
1/4	0.250	6.35000	3/4	0.750	19.05000
17/64	0.265625	6.74687	49/64	0.765625	19.44687
9/32	0.28125	7.14375	25/32	0.78125	19.84375
19/64	0.296875	7.54062	51/64	0.796875	20.24062
5/16	0.3125	7.93750	13/16	0.8125	20.63750
21/64	0.328125	8.33437	53/64	0.828125	21.03437
11/32	0.34375	8.73125	27/32	0.84375	21.43125
23/64	0.359375	9.12812	55/64	0.859375	21.82812
3/8	0.375	9.52500	7/8	0.875	22.22500
25/64	0.390625	9.92187	57/64	0.890625	22.62187
13/32	0.40625	10.31875	29/32	0.90625	23.01875
27/64	0.421875	10.71562	59/64	0.921875	23.41562
7/16	0.4375	11.11250	15/16	0.9375	23.81250
29/64	0.453125	11.50937	61/64	0.953125	24.20937
15/32	0.46875	11.90625	31/32	0.96875	24.60625
31/64	0.484375	12.30312	63/64	0.984375	25.00312
1/2	0.500	12.70000	1	1.00	25.40000

WESTERBEKE GASOLINE GENERATOR



WESTERBEKE CORPORATION • MYLES STANDISH INDUSTRIAL PARK
150 JOHN HANCOCK ROAD • TAUNTON MA 02780-7319 • TEL. (508)823-7677
FAX (508)884-9688 • WEBSITE: WWW.WESTERBEKE.COM

1191- 7/2014