

We reserve all rights to this drawing, to any patents or patent registrations related hereto, and to the duplication, retransmission by third parties and misc. use. Any use of this drawing is not permitted without the written consent of STABILUS.

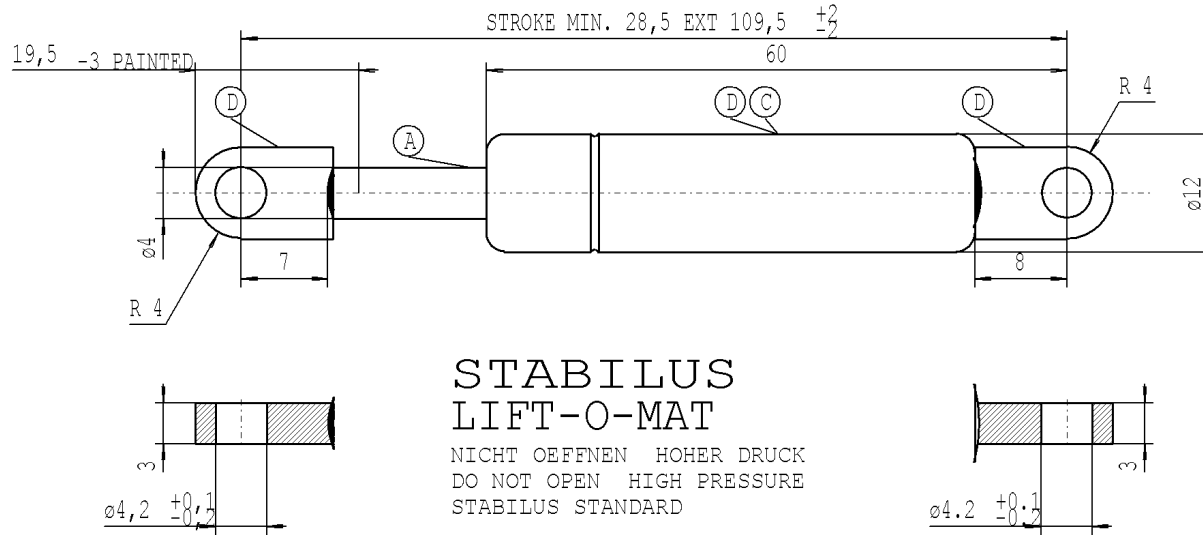

STABILUS LIFT-O-MAT

NICHT OEFFNEN HOHER DRUCK
DO NOT OPEN HIGH PRESSURE
STABILUS STANDARD

- The warning label must not be removed or obscured.
- the Gas Spring must not be mechanically modified or damaged.
- Extension speed VS2=0,1-0,4 (m/s)
- compression and extension forces measured acc. to STAB-Spec. 10009033
- Extension speed measured according to STAB-Spec. 10005451
- Spring test with piston rod downwards
- Line up connections permissible deviation ± 5 DEG
- Protect piston rod from dirt, paint and damage
- Disposal acc. to STAB-Spec.10009375
- Drawing not true-to-scale
- Observe installation instructions according to STAB-Spec. 10005593
- Installation: With piston rod down to ensure best possible durability performance of the gas spring.
- Component testing gas spring acc. STAB-Spec. 10010035
- Permissible operating temperature range -30°C to $+80^{\circ}\text{C}$

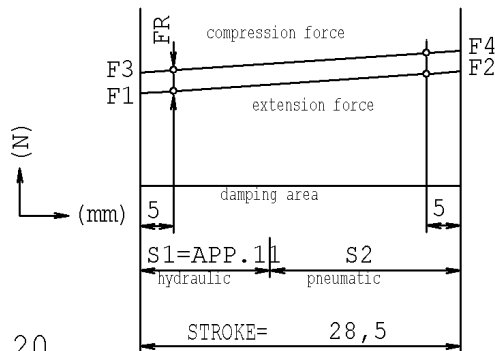

$X = F2/F1 = 1,20$
 $FR_{max} = F3 - F1$

A | Nislid black
C | print white
D | black painted

CHANGE	NEW	ÜBERARBEITUNG
	OLD	ø
	CHG.NO.	1908/92
	NAME	26.10.92 SCHNASS
	NO.	5

Unregistered Copy
Print-out is not subject to the modification service

STABILUS

Modifications in favour of technical process reserved

Forces (statically measured)

F1 (N)	F4 max (N)	FR max (N)
extension force	compression force	friction
80 \pm 15	160	25

DIMENSIONS WITH-
OUT TOLERANCE

LIFT-O-MAT

+/-1

03 01 0410 10 028

DRAWING CHECKED

DATE 24.03.1992 NAME JOBELIUS

Document No. 10005393

285611

E

Intended for internal use
and customer